



Search

ANY Word

ALL Words

[Product Lines](#) [About EDMO](#)
[Comments?](#)

Toll Free: (800) 235-3300 Toll Free Fax: (800) 828-0623

Phone: (509) 535-8280 Fax: (509) 535-8266

[Product Lines](#) ➔ [Installation and Bench Supplies](#) ➔ [Connectors](#) ➔ [BNC](#)

**Closeouts
Up To 99%
Off!**

Login

Username:

Password:

General Info

- [Login](#)
- [NEW! EDMO Catalog](#)
- [GSA Parts](#)
- [Auctions](#)
- [Find A Dealer](#)
- [Weather](#)
- [Dealer Application](#)
- [Printable Order Form](#)
- [Government Sales](#)
- [About EDMO](#)
- [EDMO Team](#)
- [EDMO Quality Manual](#)
- [Contact Us](#)
- [Sitemap](#)
- [FAQ](#)

[EDMO Asia/Pacific](#)



Description

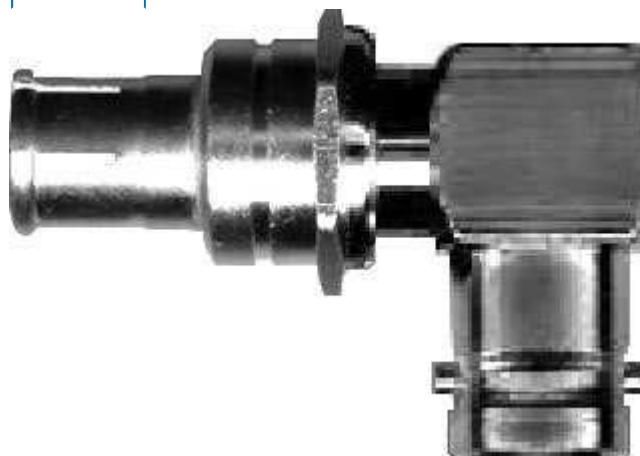

BNC TRAY ADAPTER W/ SNAP RING (DBA-600)

DBA-600 BNC Tray Adapter.

[Recommend this item to a friend](#)



Deklin Technologies

[Log In for Pricing](#)

Customers ordering this item also purchased...



BNC MALE/DUAL CRIMP/RG58 (225395-1)



24-20G CRIMP SOCKET (205090-1)



BNC MALE/DUAL CRIMP/RG142/400 (225395-6)



WIRE SPOON/STAINLESS STEEL (MDA-3792)



5 AMP KLIXON CIRCUIT BREAKER (7277-2-5)



TRAY MOUNT RF ANTENNA CONNECT (9-30-10)

© Copyright 2007 EDMO Distributors