

DATE	REV	COMMENTS
	A	INITIAL RELEASE
	A1	A/R 780 MINOR DOC CHANGES

COMPUTER CONTROLLED DRAWING  
DO NOT REVISE MANUALLY

DOTTED AREA REPRESENTS THE SN3500 INTERCONNECT.  
THE BALANCE OF THE DATA IS SHOWN FOR REFERENCE

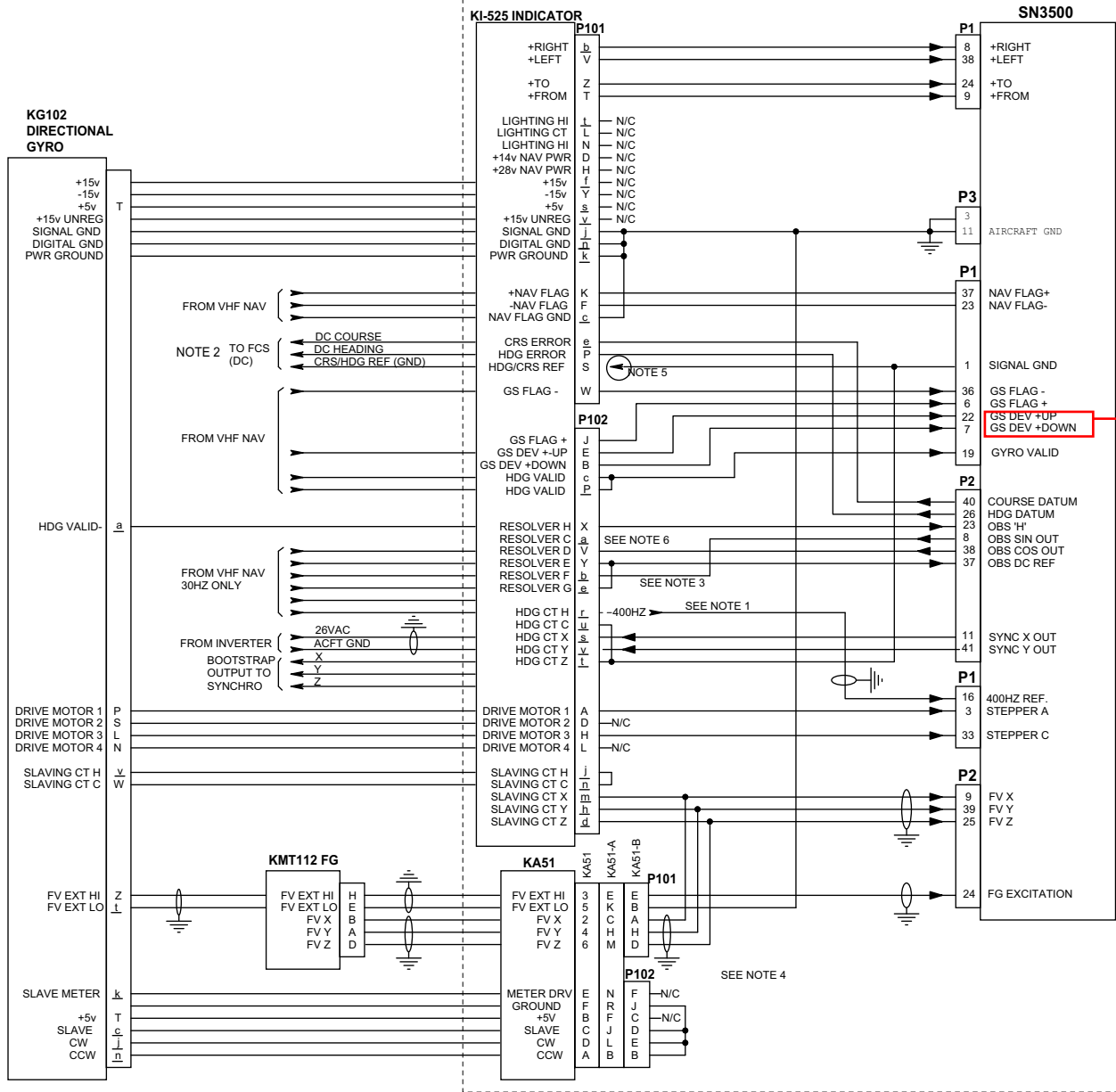

These two labels are swapped over

- NOTES:
- 1: THE SYSTEM 400HZ INVERTER WILL NORMALLY BE CONNECTED TO THE HEADING SYNCHRO 'H' TERMINAL. THIS WIRE CAN BE USED TO DRIVE THE SN3500 REFERENCE INPUT. IN AN UNUSUAL CASE THE SYNCHRO MIGHT HAVE BEEN WIRED IN UPSIDE DOWN AND THE 400HZ REFERENCE MAY BE ON THE 'C' TERMINAL.
  - 2: IF AN EXISTING CONVERTER IS INSTALLED SUCH AS A KA 52 OR KA 57, LEAVE UNIT INSTALLED AND SELECT KI525 ON FCS EMULATION PAGE.
  - 3: SHOWN IS THE 30HZ RESOLVER INTERCONNECT. CHECK APPROPRIATE NAV RECEIVER SCHEMATICS BEFORE APPLYING POWER. TYING PINS E/G TOGETHER AS SHOWN ASSUMES THEM TO BE THE NAV RECEIVER VREF. THESE ARE NORMALLY TIED TOGETHER INSIDE THE NAV RECEIVER AND GO TO SIGNAL GROUND OR AN INTERNAL DC REFERENCE VOLTAGE. IF THESE DO NOT TIE INTERNALLY PLEASE CALL SANDEL FOR ASSISTANCE.
  - 4: WHEN CONVERTING KCS-55 SYSTEM INSTALLATIONS THE KA-51 SLAVING ACCESSORY IS NOT USED. THE FLUXGATE EXCITATION SIGNAL CAN BE PICKED UP FROM THE EXISTING KA-51 CONNECTORS AS SHOWN.
  - 5: PRIOR TO INSTALLING THE SN3500, ENSURE THAT THIS WIRE IS COMING FROM THE FLIGHT CONTROL SYSTEM GROUND AND THAT NO VOLTAGE IS PRESENT ON THIS PIN WITH POWER APPLIED TO ALL AVIONICS. IF VOLTAGE IS PRESENT, CONNECT SN3500 P1-1 TO FCS GROUND AT THE ROLL COMPUTER WITH A NEW WIRE. IF PRIMARY POWER IS APPLIED TO SN3500 P1-1 DAMAGE MAY OCCUR TO THE SN3500 RESULTING IN AN OPEN CIRCUIT AT P1-1. THIS CAN BE CHECKED WITH AN OHM METER.
  - 6: RESISTOR MAY BE REQUIRED. SEE RESOLVER INTERCONNECT SHEET TO DETERMINE PROPER CONNECTION.

**SANDEL** Vista, Ca.

Category: SN3500 INSTALLATION DRAWING

Title: KCS-55 REMOVAL (REF)

Size B Document Number 82005-10 Rev A1

Create: Saturday, May 02, 1998 Mod: Sunday, December 09, 2007 Sheet 19