

## Description

Single pole, miniaturised thermal circuit breaker with trip-free mechanism and push/pull on/off manual actuation (M-type TO CBE to EN 60934). Threadneck panel mounted, temperature-compensated, with optional auxiliary contacts. Fully approved for commercial aircraft and similar requirements.

## Typical applications

Extra low voltage wiring systems on all types of vehicles for land, sea and air.

## Ordering information

### Type No.

4120 single pole, with temperature compensation

### Mounting

**G** threadneck panel mounting

**L** threadneck panel mounting, extended push button

### Threadneck design

**1** M12x1x6.3 (aluminium)

**2** 7/16-32 UNx6.3 (aluminium)

### Number of poles

**1** 1-pole, thermally protected

### Hardware for threadneck

**0** without hardware

**1** hex nut M12x1, corrugated washer 12/15, fitted

**2** hex nut M12x1 (aluminium), serrated lock washer 12.1/17.2, fitted

**3** hex nut M12x1 (aluminium), serrated lock washer 12.1/17.2, bulk shipped

**4** hex nut 7/16-32UN (aluminium), serrated lock washer 11.3/14.9, fitted

### Terminal design (main terminals)

**K1** screw terminals with metric thread K14 (M4)

**J1** screw terminals with inch thread J14 (8-32UNC-2B)

**J2** screw terminals with inch thread J17 (8-32UNC-2B)

**J3** screw terminals with inch thread J25 (6-32UNC-2B)

**P1** blade terminals 6.3x0.8, DIN 46244, silver-plated

### Characteristic curve

**M1** thermal, 1.15 - 1.38 I<sub>N</sub>

### Terminal screws

**A** Phillips screw M4x6, fitted

**B** Phillips screw 8-32UNC-2Ax6, fitted

**C** Phillips screw 6-32UNC-2Ax6 (MS 51957-26)

**D** slotted flat head screw M4x6, fitted

**K** hex screw with Phillips head 8-32UNC-3Ax7.6, fitted

**M** hex screw with Phillips head 8-32UNC-3Ax7.6, bulk shipped

**Z** without terminal hardware

### Terminal washers

**0** without lock washer

**1** wave washer B4, fitted

**2** lock washer 4.3, fitted

**4** lock washer 3.7 (MS 35338-136)

**5** lock washer 4.3/9, fitted

**6** lock washer 4.3/9, bulk shipped

### Auxiliary contact

**S0** without auxiliary contact

**S1** with auxiliary contact (connector EN 3155-016M2018) (NC)

**S5** with polarized auxiliary contact (NC)

### Barrier

**Z** without barrier

**U** with barrier (19.5 wide)

### Colour of the push button

**G** green to EN (e. g. 2 1/2)

**N** black to EN (e. g. 2 1/2)

**S** black, with white marking (e. g. 2.5)

**X** black, without marking

### Current ratings

**1...25 A**

4120 - G 1 1 1 - K1 M1 - A 1 S0 Z N - 10 A ordering example



4120-...

## Technical data

Voltage rating	AC 115 V (400 Hz); DC 28 V	
Current rating range	1...25 A (0.5 A upon request)	
Auxiliary circuit	1 A, DC 28 V (0.5 A upon request)	
Typical life	20,000 operations mechanical, or 5,000 operations at 1 x I <sub>N</sub>	
Ambient temperature	-55°C ...+125°C (-67...+257 °F)	
Insulation co-ordination (IEC 60664 and 60664A)	rated impulse withstand voltage 1.5 kV	pollution degree 3
Dielectric strength (IEC 60664 and 60664A)	test voltage operating area main to aux. circuit	AC 1,500 V AC 1,500 V
Insulation resistance	> 100 MΩ (DC 500 V)	
Interrupting capacity I <sub>cn</sub>	AC 115 V (400 Hz):	1...4 A 1,000 A 5...25 A 2,000 A 1...25 A 6,000 A
	DC 28 V:	
Degree of protection (IEC 60529/DIN 40050)	operating area IP40 terminal area IP00	
Vibration (sinusoidal)	10 g (57-2000 Hz), ± 0.76 mm (5-57 Hz) to ISO 7137, EN 2350 para. 5.3.1	
Vibration	1...2.5 A: 0.04 g <sup>2</sup> /Hz ± 1,5 dB; 7.3 g eff 3...20 A: 0.06 g <sup>2</sup> /Hz ± 1,5 dB; 9 g eff to ISO 7137, EN 2350 para. 5.3.1	
Acceleration	17 g, to ISO 2669, EN 2350 para. 5.3.3	
Shock	50 g (11 ms), to ISO 7137, EN 2350 para. 5.3.2	
Corrosion	48 hours at 5 % salt mist to ISO 7137, EN 2350 para. 5.4.2	
Humidity	240 hours at 95 % RH, to ISO 7137, EN 2350 para. 5.4.3	
Explosion	to VG 95210, sheet 10	
Altitude	≤ 22,000 m above sea level	
Mass	approx. 20.6 g with terminal screws, without -Si approx. 24.6 g with terminal screws, with -Si	

## Standard current ratings and typical volt drop values

Current rating (A)	Volt drop (mV)	Current rating (A)	Volt drop (mV)
1	1100	7.5	250
2	550	10	230
2.5	460	15	200
3	440	20	190
4	380	25	190
5	260		

## Approvals (configurations)

Authority	Voltage ratings	Current ratings
EN 2495		
EN 3773		
EN 2995		
MS 3320		
QPL		
VG 95345 T06	DC 28 V; AC 115 V	0.5...20 A
BWB (to VG 95345, part 6)		
UL 1077	DC 50 V	0.5...25 A

## Dimensions 4120-...

### 4120-G214-J1M1-B2S0ZN (MS 3320)

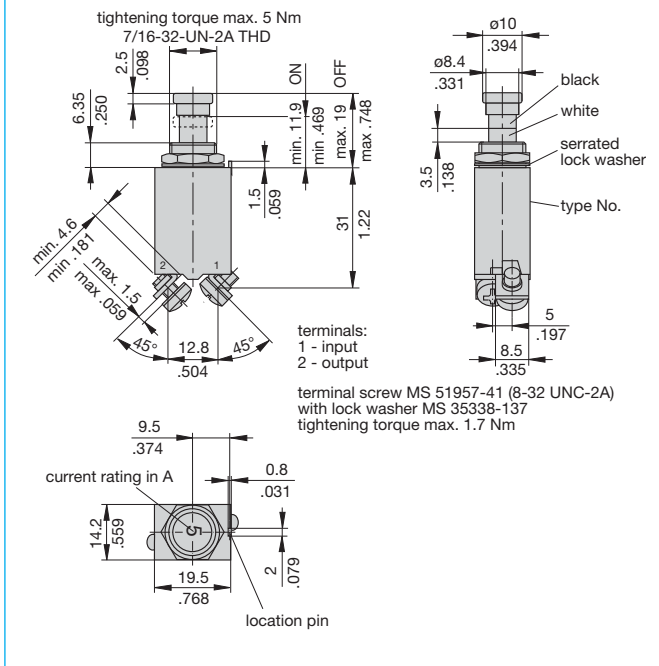

## Dimensions 4120-G1..

### 4120-G111-K1M1-A1S0ZN (EN2495-...M) (VG95345 T06)

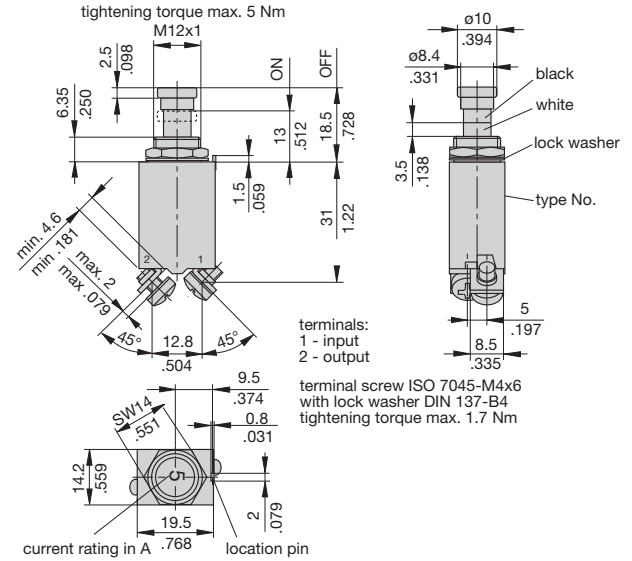

### 4120-G11-J2M1-K5S0ZN (EN2495-...U, EN3773-004 D...)

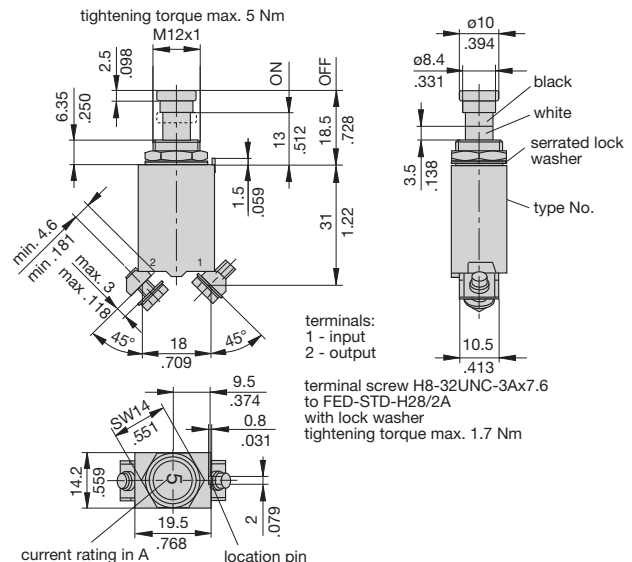

### 4120-G112-J2M1-K5S1ZG - 4120-G112-J2M1-K5S5ZG (EN2995-004) (EN2995-005)

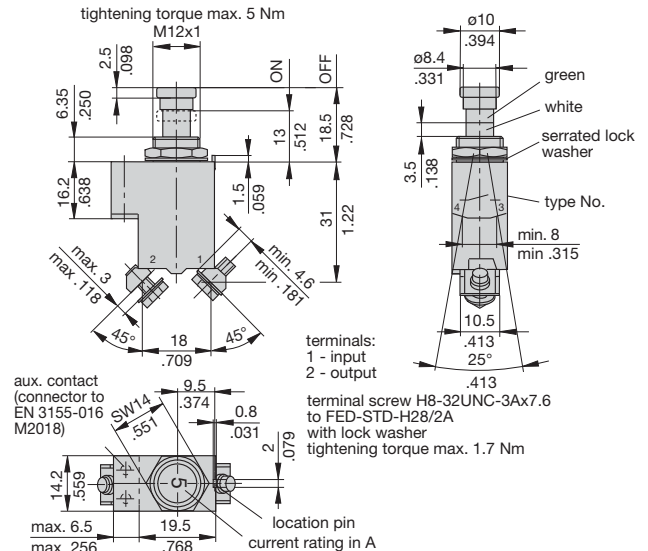

This is a metric design and millimeter dimensions take precedence (mm/ inch)

## Mounting holes

### 4120-G2...

### mounting holes S0

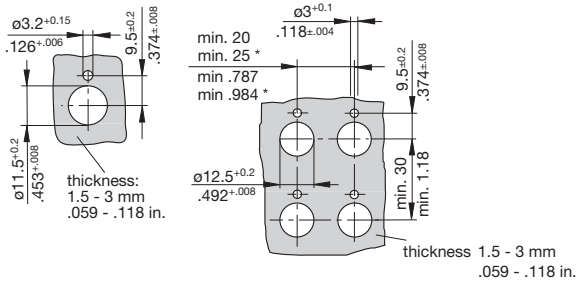

### 4120-G1...

### mounting holes S1 or S5

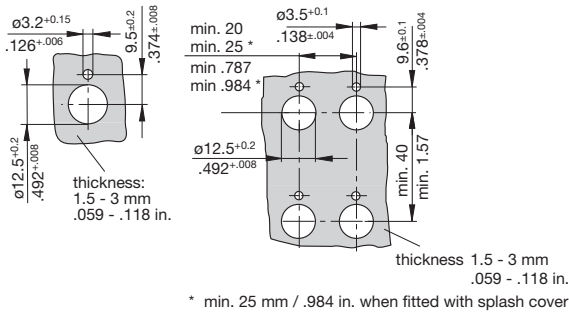

## Internal connection diagram

### with auxiliary contact VG 95345 T06

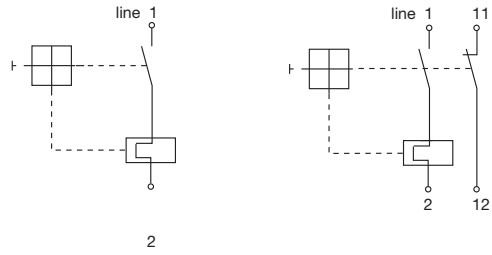

### with auxiliary contact EN 2995-004

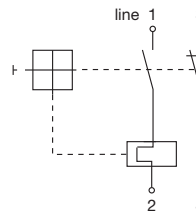

### with polarized auxiliary contact EN 2995-005

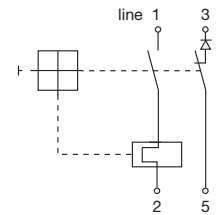

## Other terminal designs

### Terminal design -J2

Terminal distances to:  
MS 14 105 (a, b)  
MS 14 153 (a, b)  
MS 22 073 (a)  
MS 22 074 (a)  
MS 25 244 (a)  
MS 25 373 (a, b)

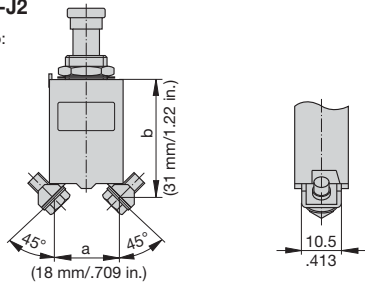

### Terminal design -J3

Terminal distances to:  
MS 26 574 (a, b)

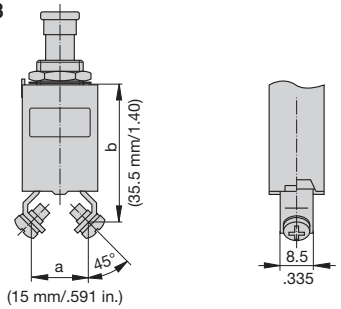

### Terminal design -P1

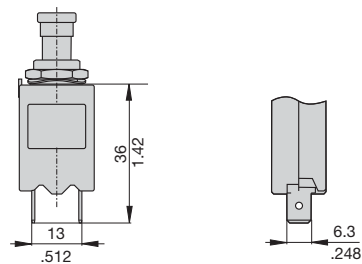

## Typical time/current characteristics

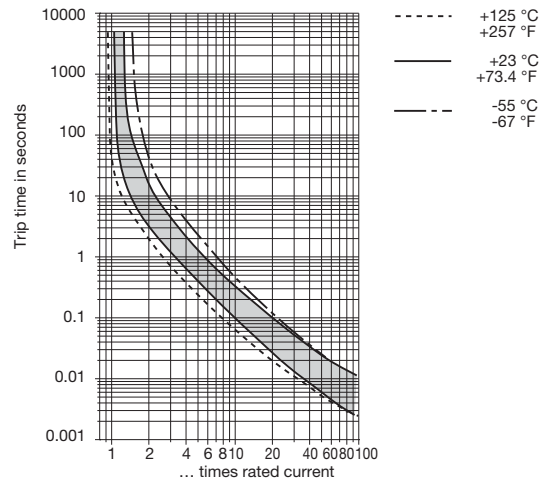

This is a metric design and millimeter dimensions take precedence ( $\frac{\text{mm}}{\text{inch}}$ )

## Accessories (approved to VG 95 345, part 23)

**Splash cover/hex nut assembly with O ring (IP66 and IP67)**  
 X 200 801 08 nickel plated nut, transparent cover  
 X 200 801 03 matt black finish nut, black cover  
 X 200 801 09 matt black finish nut/16-32, black cover

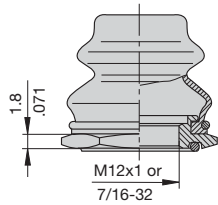

**Actuator extension (black) to be fitted on the push button**  
 X 200 803 01

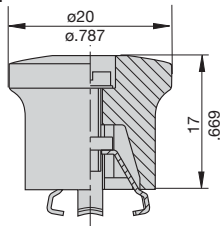

## Accessories

**Identification collar to be snapped on the push button**  
 Y 307 004 01 black  
 Y 307 004 02 white  
 Y 307 004 03 red  
 Y 307 004 04 green  
 Y 307 004 05 blue

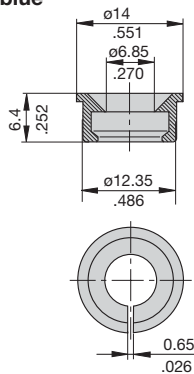

**Lock out ring to block the push button in OFF position**  
 Y 307 005 01 red  
 Y 307 005 02 black

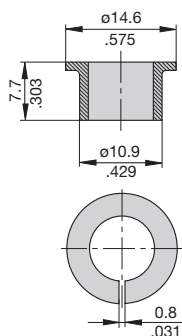

This is a metric design and millimeter dimensions take precedence ( $\frac{\text{mm}}{\text{inch}}$ )

All dimensions without tolerances are for reference only. In the interest of improved design, performance and cost effectiveness the right to make changes in these specifications without notice is reserved. Product markings may not be exactly as the ordering codes. Errors and omissions excepted.