

PPL/IR Europe

RNAV Training Manual

Vasa Babic

June 2008 v1.8

- This manual covers the RNAV theoretical knowledge and ground training for an Instrument Rated pilot operating single-pilot general aviation aircraft under IFR in Europe, specifically
 - to meet the requirements of JAA TGL10 and FAA AC90-96A for P-RNAV qualification
 - to meet various national requirements or recommendations for flying RNAV(GPS) Approaches, eg. UK CAA CAP 773
- The manual also has a recommended syllabus to meet flight training requirements for P-RNAV and RNAV(GPS) Approaches
- It is intended to be used in a classroom training seminar, distance-learning course or for self-study
- Some of the detailed content and reference material is beyond the scope of what is required for pilot training. The pages of the document are coded, in the top right corner, as follows:



P

Indicates that page content is required for P-RNAV training based on this Manual



A

Indicates that page content is required for GPS Approach training based on this Manual



P A

Indicates that page content is required for both P-RNAV and GPS Approach training based on this Manual



Indicates that page content is not essential for a training course

- Garmin software and user manual content is reproduced with the kind permission of Garmin
- Jeppesen charts are reproduced with the kind permission of Jeppesen
- UK CAA charts and documents are reproduced with the kind permission of the UK CAA
- The author would like to thank Mr. Julian Scarfe for reviewing this document in detail and for his very knowledgeable feedback. Errors and omissions are entirely the author's responsibility

- *The document, in PDF form, is available for free to the aviation community. If you find this material valuable, you are asked to:*
 - *please consider joining and/or donating to PPL/IR Europe (www.pplir.org). This small voluntary organisation serves GA IFR pilots in Europe by publishing and exchanging information to help promote the safety and utility of IFR flight in single-pilot aircraft, and works with regulators in Europe to ensure they have input on the specialised needs of private IFR from a credible and qualified source*
 - *please also join and support your national AOPA. Internationally, AOPA is the only GA representative organisation for private pilots accredited to ICAO, the FAA, EASA and national regulators. IFR regulations are planned and decided upon many years in advance, at a global and regional level. AOPA needs your support to make sure that private IFR operators continue to have practical and cost-effective access to airspace worldwide*

1. RNAV and RNP theory
 - a. Introduction**
 - b. The Path-Terminator
 - c. RNAV procedure design
 - d. RNP principles
 - e. RNAV and RNP applications
2. GPS Navigators and their application to RNAV
 - a. The GPS system
 - b. Databases and Coding
 - c. Procedures
 - d. Error detection and warnings
3. P-RNAV Terminal Procedures
 - a. P-RNAV requirements and approvals
 - b. P-RNAV training topics
 - c. P-RNAV operations
4. RNAV(GPS) Approach Procedures
 - a. GPS procedure types
 - b. GPS approach requirements and approvals
 - c. GPS approach operations
5. Avionics training
6. Simulator and/or Flight training

What is the basic concept of RNAV?

“Traditional” IFR Navigation

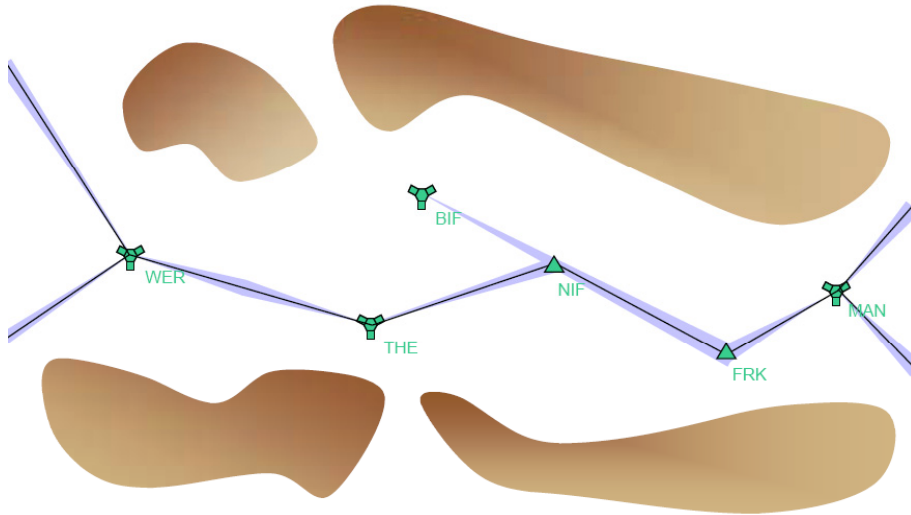

- “Traditional” IFR Navigation relies on aircraft crossing radio beacons and tracking to and from them directly, or via intersects
- This constrains IFR routes and procedures to what is achievable from a limited and expensive infrastructure of ground-based stations

RNAV

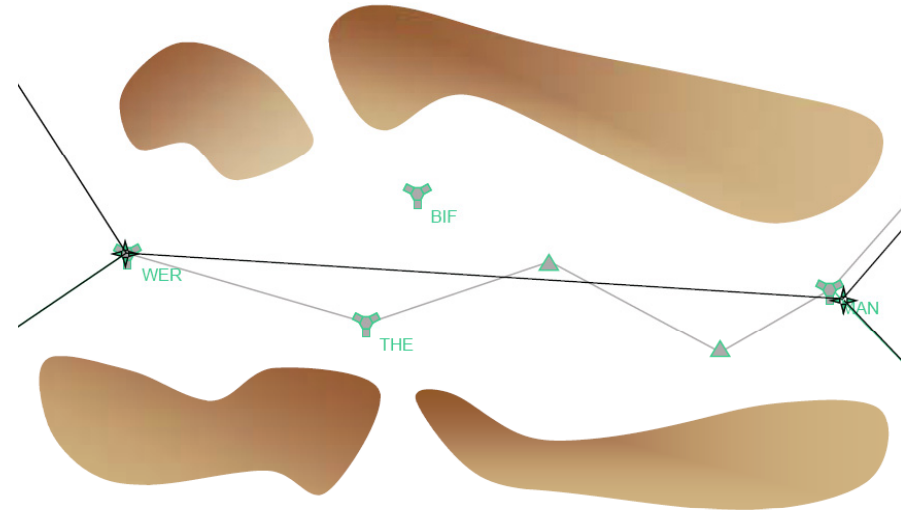

- Area Navigation (RNAV) is a method of navigation that permits aircraft to follow IFR routes and procedures based on any desired routing, subject to the system limits of the RNAV technology
 - Initially, in the 1970s, based on VOR-DME “shifting” or systems like Loran C; limited by station range and coverage. Large jets also used Inertial Navigation Systems.
 - Modern RNAV in general aviation aircraft is based on panel-mounted GPS. Transport aircraft also use Inertial Reference and DME-DME in multi-sensor Flight Management Systems (FMS)

How is RNAV implemented?

- Traditional IFR has a single, simple “implementation” which is valid in airspace worldwide using a standard set of aircraft equipment (the VOR, DME, ADF and ILS receivers and instruments) and the standard Instrument Rating pilot qualification. Non-standard applications are relatively rare and specialised (eg. CAT 2 ILS operations)
- First-generation RNAV was implemented in much the same way. Aircraft equipped with one of the many kinds of RNAV “box” could fly additional RNAV routes. However, the accuracy and predictability of an aircraft’s flight path was limited by a lack of standardisation
 - in navigation equipment accuracy and reliability
 - in how route and procedure data was entered, coded, interpreted and displayed
 - in how pilots and autopilots would fly turns, intercepts, climbs to a fix and any other “non-straight and level” legs
- Modern applications have aimed to increase the usefulness of RNAV by allowing very precise procedure designs that use airspace more efficiently and create more direct routes. This also has the benefit of improving terrain and traffic separation, and providing better noise abatement and fuel-efficient descent management
- However, to date, no homogenous way of providing the standards and safeguards needed for accurate and consistent RNAV has emerged, and thus there are a variety of RNAV applications in different regional and national airspace and for different phases of flight (enroute, terminal, approach)
 - eg. B-RNAV and P-RNAV in Europe, MNPS in the North Atlantic, RNAV 1 and RNAV 2 in the US

What is RNP (Required Navigation Performance) ?



- RNP terminology can be confusing, because it means slightly different things in different contexts
- RNP, *conceptually*, is “a measure of the navigation performance accuracy necessary for operation within a defined airspace”
- RNP, as a *performance specification*, is a measure of the lateral accuracy in nautical miles, relative to a desired flight path, that an aircraft can be expected to maintain 95% of the total time
 - Referred to as “RNP-X” where the “X” may be, for example, 5nm
- RNP is also used as the name for *RNAV applications* that include a specific RNP-X requirement
 - For example, RNP 10 is the name for an Oceanic RNAV application. Aircraft operating on routes designated as RNP 10 must conform to a variety of equipment, crew and operator approval requirements.
 - However, RNAV application names are not standardised: in the North Atlantic, the RNAV application is very similar to RNP 10, but it is called “Minimum Navigation Performance Specifications” (MNPS). Europe and the USA both have Terminal RNAV applications based on RNP-1, but they are called P-RNAV and RNAV 1 respectively
- ICAO is in the process of standardising RNAV and RNP applications and specifications. The general term for this is “Performance Based Navigation” (PBN); this will change, and in some cases replace, the use of RNP concepts

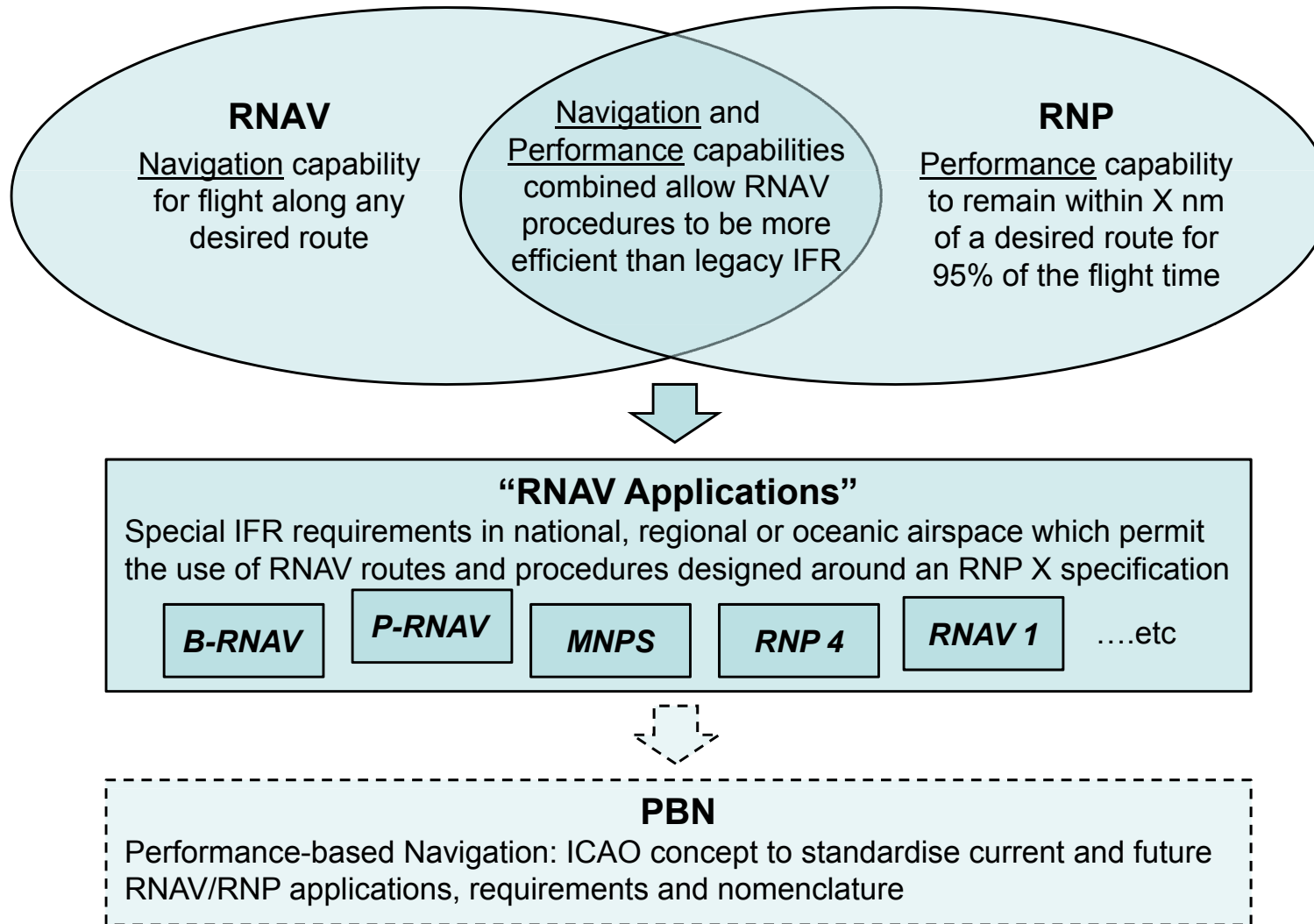







1. RNAV and RNP theory
 - a. Introduction
 - b. The Path-Terminator**
 - c. RNAV procedure design
 - d. RNP principles
 - e. RNAV and RNP applications
2. GPS Navigators and their application to RNAV
 - a. The GPS system
 - b. Databases and Coding
 - c. Procedures
 - d. Error detection and warnings
3. P-RNAV Terminal Procedures
 - a. P-RNAV requirements and approvals
 - b. P-RNAV training topics
 - c. P-RNAV operations
4. RNAV(GPS) Approach Procedures
 - a. GPS procedure types
 - b. GPS approach requirements and approvals
 - c. GPS approach operations
5. Avionics training
6. Simulator and/or Flight training

What is a Path-Terminator?

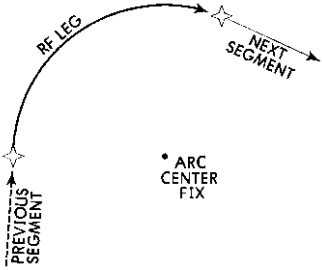
- IFR routes and procedures are designed using standardised specifications and criteria
 - ICAO PANS-OPS Doc 8168 in Europe
 - TERPS (United States Standard Terminal Instrument Procedures) in the USA
- Instrument procedures have always been published in chart and text form. Since the 1970s, the ARINC 424 standard has also been used to codify IFR procedures, so they can be stored and managed as records in electronic databases
- A key concept in ARINC 424 is that of the “Path-Terminator” – a specific way of defining a leg or segment of an IFR procedure, based on a set of standard components that define the flight *path* along the leg, and the *terminator* or end-point of the leg
- Different combinations of Path types (eg. a Heading or a Track) and Terminator types (eg. a radio beacon, RNAV waypoint or DME arc) are used to define 23 different “Path-Terminator” leg types
 - **these 23 Path-Terminator types are, in effect, the “periodic table” of IFR procedure design and codification**
- In a panel-mounted GPS Navigator, an enroute flight plan consists only of one leg type: the basic “Track (from Fix) to Fix” (TF) between each of the waypoints entered. When a Departure, Arrival or Approach procedure is loaded, the flight plan will include each of the path-terminators that make up the **procedure**. Note: some GPS units do not support all the leg types used at the start and end of RNAV procedures, or in an unpublished GPS “overlay”

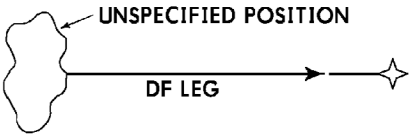
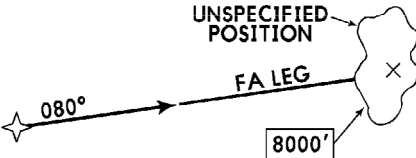
ARINC 424 Path-Terminator leg types (1 of 3)

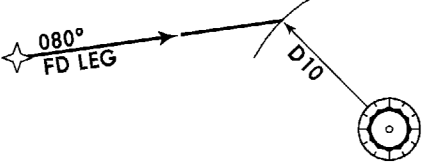
IF leg type	TF leg type	RF leg type	CF leg type
<ul style="list-style-type: none"> The Initial Fix Leg defines a database fix as a point in space It is only required to define the beginning of a route or procedure 	<ul style="list-style-type: none"> Track to a Fix defines a great circle track over ground between two known database fixes Preferred type for straight legs 	<ul style="list-style-type: none"> Constant Radius Arc Leg defines a constant radius turn between two database fixes, lines tangent to the arc and a center fix 	<ul style="list-style-type: none"> Course to a Fix Leg defines a specified course to a specific database fix TF legs preferred over CF to avoid magnetic variation issues
			
DF leg type	FA leg type	FC leg type	FD leg type
<ul style="list-style-type: none"> Direct to a Fix Leg defines an unspecified track starting from an undefined position to a specified fix 	<ul style="list-style-type: none"> Fix to an Altitude Leg defines a specified track over ground from a database fix to a specified altitude at an unspecified position 	<ul style="list-style-type: none"> Track from a Fix to a Distance Leg defines a specified track over ground from a database fix for a specific distance 	<ul style="list-style-type: none"> Track from a Fix to a DME Distance Leg defines a specific track from a database fix to a specific DME Distance from a DME Navaid
			

ARINC 424 Path-Terminator leg types (2 of 3)

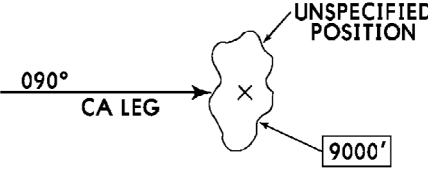
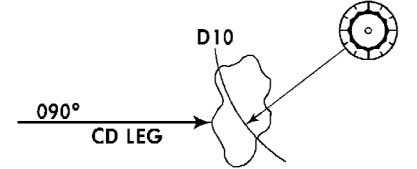
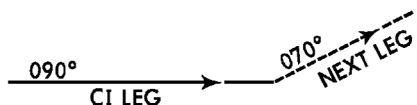
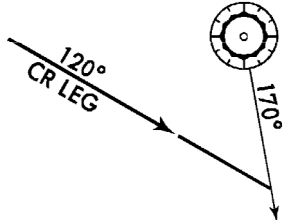
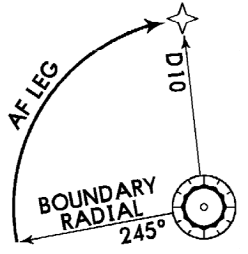
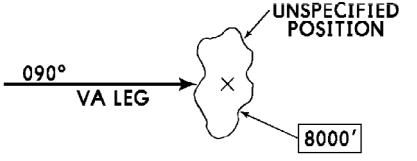
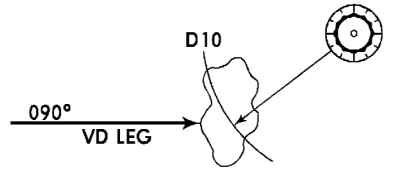
FM leg type	CA leg type	CD leg type	CI leg type
<ul style="list-style-type: none"> From a Fix to a Manual termination Leg defines a specified track over ground from a database fix until Manual termination of the leg 	<ul style="list-style-type: none"> Course to an Altitude Leg defines a specified course to a specific altitude at an unspecified position 	<ul style="list-style-type: none"> Course to a DME Distance Leg defines a specified course to a specific DME Distance which is from a specific database DME Navaid 	<ul style="list-style-type: none"> Course to an Intercept Leg defines a specified course to intercept a subsequent leg
			
CR leg type	AF leg type	VA leg type	VD leg type
<ul style="list-style-type: none"> Course to a Radial termination Leg defines a course to a specified Radial from a specific database VOR Navaid 	<ul style="list-style-type: none"> Arc to a Fix or defines a track over ground at specified constant distance from a database DME Navaid 	<ul style="list-style-type: none"> Heading to an Altitude termination Leg defines a specified heading to a specific Altitude termination at an unspecified position 	<ul style="list-style-type: none"> Heading to a DME Distance termination Leg defines a specified heading terminating at a specified DME Distance from a specific database DME Navaid
			

ARINC 424 Path-Terminator leg types (3 of 3)

VI leg type	VM leg type	VR leg type	PI leg type
<ul style="list-style-type: none"> Heading to an Intercept Leg defines a specified heading to intercept the subsequent leg at an unspecified position 	<ul style="list-style-type: none"> Heading to a Manual termination Leg defines a specified heading until a Manual termination 	<ul style="list-style-type: none"> Heading to a Radial termination Leg defines a specified heading to a specified radial from a specific database VOR Navaid 	<ul style="list-style-type: none"> Procedure Turn leg defines a course reversal starting at a specific fix, includes Outbound Leg followed by 180 degree turn to intercept the next leg
HA leg type	HF leg type	HM leg type	
<ul style="list-style-type: none"> HA leg defines racetrack pattern or course reversals at a specified database fix terminating at an altitude 	<ul style="list-style-type: none"> HF leg defines racetrack pattern or course reversals at a specified database fix terminating at the fix after a single pattern 	<ul style="list-style-type: none"> HM leg defines racetrack pattern or course reversals at a specified database fix with a manual termination 	

The ARINC 424 “periodic table” of 23 Path-Terminator legs

Terminators

Paths

	Fix to	Track from fix to	Course to	Heading to	Direct to	Racetrack	DME Arc to	Radius from fix
Fix	IF	TF	CF		DF	HF	AF	RF
Altitude		FA	CA	VA		HA		
Manual Termination		FM		VM		HM		
Distance		FC						
DME Distance		FD	CD	VD				
Intercept			CI	VI				
Radial			CR	VR				
Procedure Turn	PI							

Each leg type has a two letter name based on the path and terminator combination

Fly-By and Fly-Over RNAV waypoints

- The “fix” in Path-Terminator legs is either based on radio aids or it is an RNAV waypoint. ICAO define a waypoint as “*a specified geographical location used to define an RNAV route or the flight path of an aircraft employing RNAV*”
- There are 2 kinds of RNAV waypoint: Fly-By and Fly Over

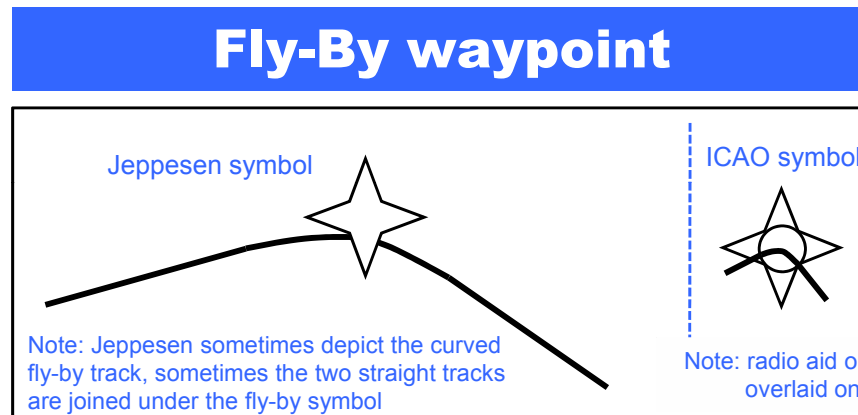

- A waypoint which requires turn anticipation (start of turn before the waypoint) to allow tangential interception of the next segment of a route or procedure
- The aircraft navigation system calculates the start of the turn onto the next route leg before the waypoint
- This is the preferred type of waypoint for all Area Navigation (RNAV) Standard Instrument Departures/Standard Instrument Arrivals (SIDs/STARs)

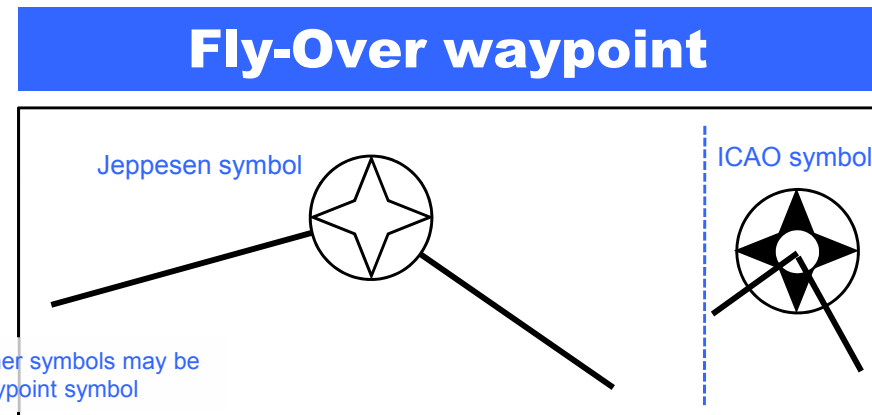

- A waypoint at which a turn is initiated
- The aircraft starts to turn onto the next route leg as it passes over the waypoint
- Fly-Over waypoints are most often used as the first fix in the missed approach procedure and in depicting traditional procedures designed around overflying radio aid fixes
- RNAV Procedure designers are increasingly avoiding the use of Fly-Over waypoints

Fly-By

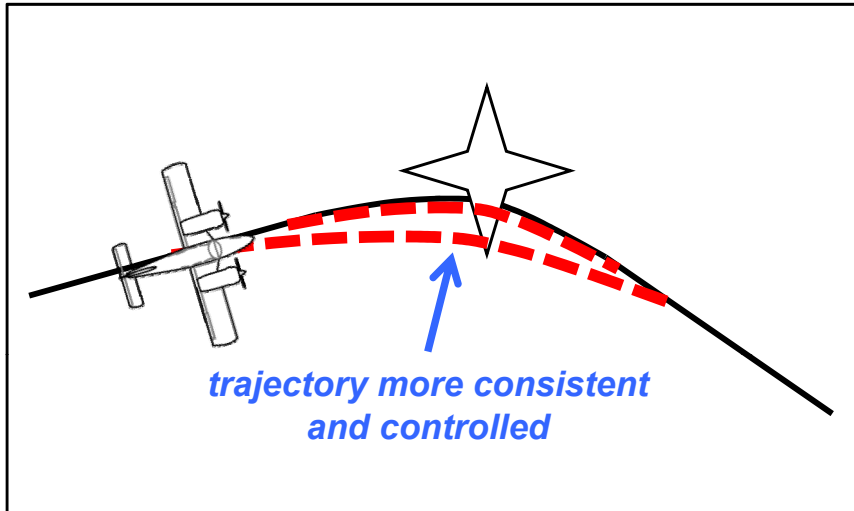

- Turn is a Rate 1 curved path tangential to both the inbound and outbound track

Fly-Over

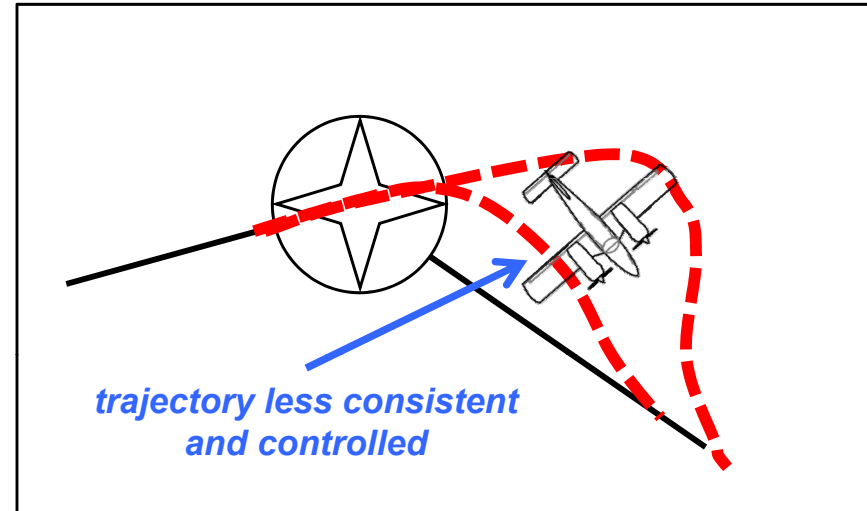

- Turn consists of roll-in, Rate 1 turn, roll-out and intercept elements

- Both types of trajectory are subject to variations in wind, aircraft speed and bank angle, navigation system logic and Pilot or Autopilot performance. However, flight paths resulting from Fly-By turns are, in practice, much more consistent and predictable, and thus preferred in RNAV procedure design (eg. they require a smaller protected area)
- **Although the Fly-By turn is a simple concept, it is important for the pilot to understand exactly how turns are annunciated and displayed on the GPS navigator and how lateral guidance is provided to the autopilot in Nav or Roll-Steer (GPSS) modes, in order to consistently and accurately achieve the tangential path the procedure requires**

1. RNAV and RNP theory
 - a. Introduction
 - b. The Path-Terminator
 - c. RNAV procedure design**
 - d. RNP principles
 - e. RNAV and RNP applications
2. GPS Navigators and their application to RNAV
 - a. The GPS system
 - b. Databases and Coding
 - c. Procedures
 - d. Error detection and warnings
3. P-RNAV Terminal Procedures
 - a. P-RNAV requirements and approvals
 - b. P-RNAV training topics
 - c. P-RNAV operations
4. RNAV(GPS) Approach Procedures
 - a. GPS procedure types
 - b. GPS approach requirements and approvals
 - c. GPS approach operations
5. Avionics training
6. Simulator and/or Flight training

1. The Protected Area

- Instrument procedures in Europe are designed using the specifications and criteria in ICAO PANS-OPS Doc 8168. The US equivalent standard is "TERPS" (United States Standard Terminal Instrument Procedures)

Profile of Protected Area

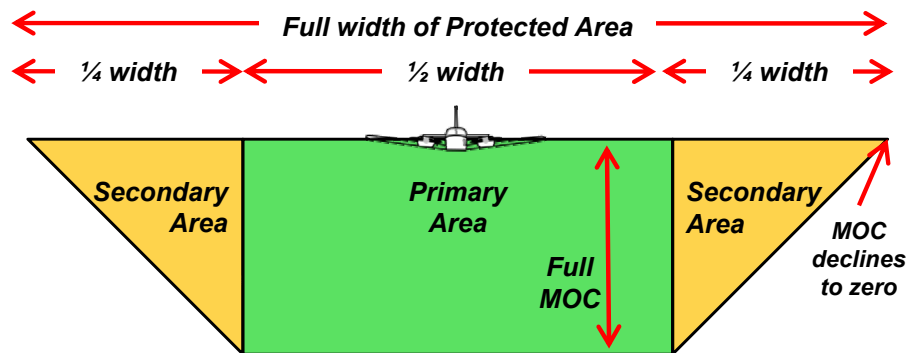

Plan View of Protected Area

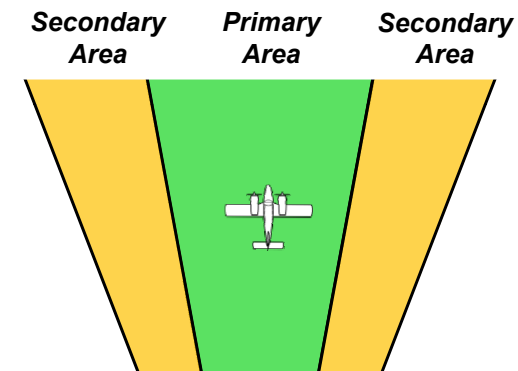

- The key design criteria is to provide safe obstacle and terrain clearance whilst an aircraft is flown in accordance with the published procedure
 - *horizontally*, within a Protected Area
 - *vertically*, with a specified Minimum Obstacle Clearance (MOC)

Principles of 'traditional' Instrument Procedure design

2. Track and Fix tolerances, and MOC

- The horizontal width of the Protected Area is determined by various tolerances relating to where an aircraft could be located whilst flying the procedure
- The key tolerance is based on the type of radio aid being tracked and distance from it. An angular splay is used that widens the protected area as the aircraft travels further from the fix

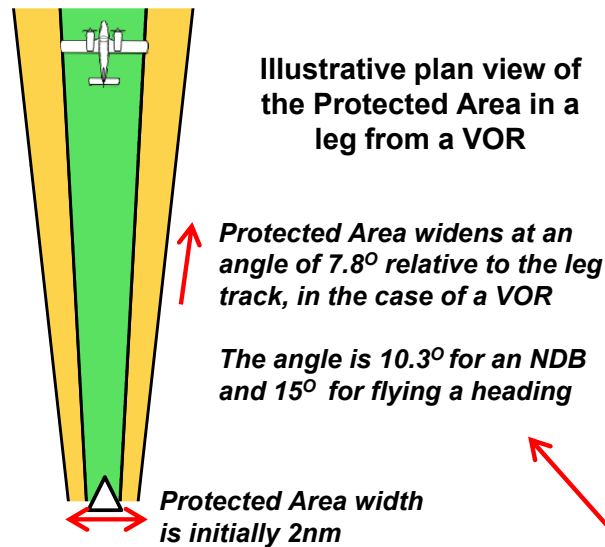

- Protection in a descent or a turn initiated at a fix is also provided by including a Fix Tolerance

Examples	VOR	NDB	DME	LOC
System Tolerance	4.5°	6.2°	0.25nm plus 1.25% of the DME distance	1.4°
Flight Technical Tolerance	0.7°	0.7°		1.0°
Total Fix Tolerance	5.2°	6.9°		2.4°

Note that fix tolerances are different from path tracking tolerances

Note: FTT excluded when fix is based on an intersect. These are illustrative examples, the full definition of fix tolerances (eg. overhead a beacon, radar fixes) is beyond the scope of this course

- The Minimum Obstacle Clearance (MOC) is 984' or 300m up to the Initial Approach Fix, and declines during the Approach and Missed Approach (down to a minimum of 98' or 30m on the missed)

Principles of 'traditional' Instrument Procedure design

3. Fly-Over Turns

- The protected area around a turn is necessarily greater than the “sum” of the track protection required to and from a fix: it must take into account
 - the fix tolerance
 - the time it takes a pilot to react to crossing the fix and establish the turn
 - the effect of worst-case wind pushing the aircraft to the outside of the turn
 - the turning radius of different aircraft types

Illustration of traditional Fly-Over turn

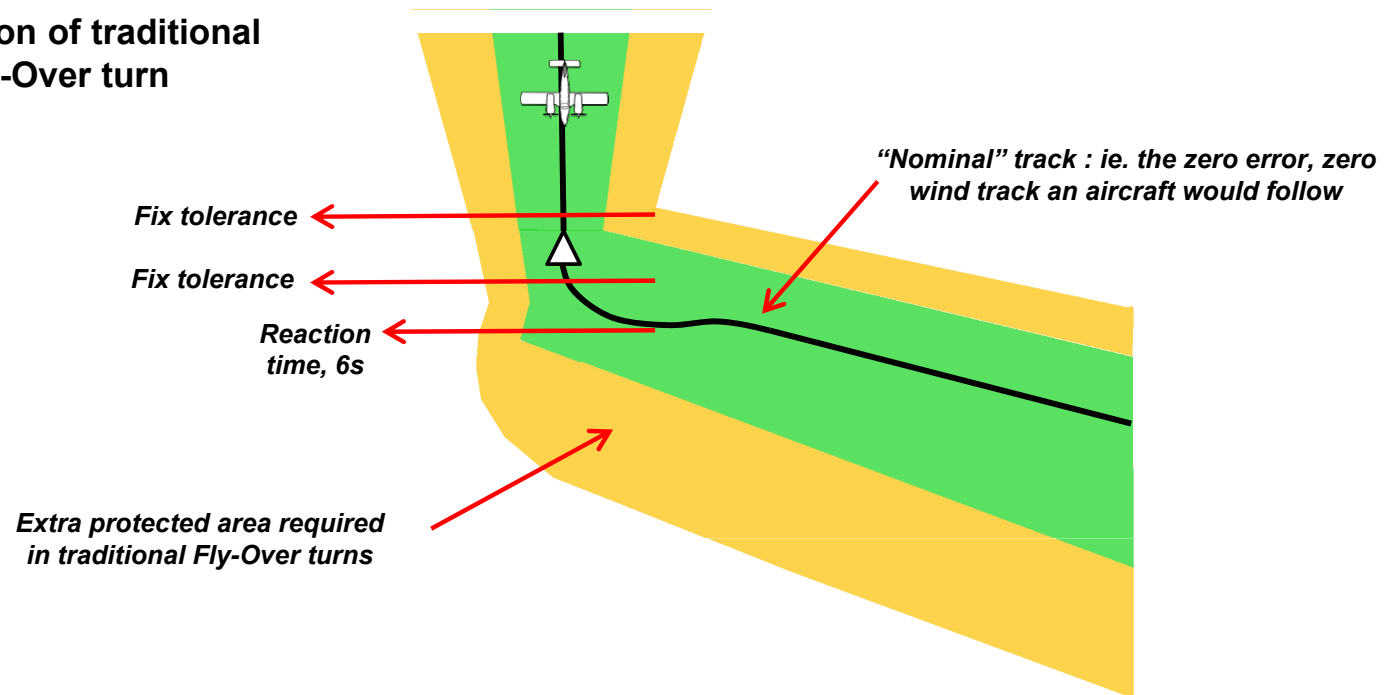

Principles of 'traditional' Instrument Procedure design

4. Aircraft Approach Categories

- Aircraft speed is the key criteria for the design of any manoeuvring elements of an instrument procedure (turns, procedure turns, holds, missed approaches, landing and circling minima)
- Procedures are designed around 5 aircraft categories, based on a notional approach speed of 1.3x the stalling speed in the landing configuration at maximum landing mass (V_{AT})

Aircraft Category	V_{AT}	Initial Approach speeds	Final Approach speeds	Max Circling speed
A	<91	90-150	70-100	100
B	91-120	120-180	85-130	135
C	121-140	160-240	115-160	180
D	141-165	185-250	130-185	205
E	166-210	185-250	155-230	240

All speeds are KT IAS

- Most general aviation aircraft are Categories A or B. However, in busy Terminal airspace, ATC will often request a higher than normal speed from light aircraft. If appropriate, the pilot should also elect to follow a higher-Category procedure and observe the corresponding minima
 - note that GPS databases usually only include the Category C&D procedures

How are RNAV Procedures different?

1. Definition of Protected Area based on RNAV system performance or RNP

Based on RNAV system type

- RNAV procedures designated for specific navigation systems, eg
 - RNAV_(GNSS)
 - RNAV_(DME-DME)
 - RNAV_(EXCEPT CLASS A GNSS)

ie. FMS GPS only, not panel mount GPS
- Each procedure type has a system-specific “semi area width”, which is the lateral protection either side of the nominal track, eg. 3nm for GPS STARS
- Modern approach is to define procedures based on RNP, not on specific navigation systems
- Fix Tolerance is based on system-specific linear Along Track (ATT) and Cross-Track (XTT) tolerances, rather than angular splays

Based on RNP

- PANS OPS protected area width is $2x$ RNP + a buffer
- Buffer is 2nm for arrival, 1nm for initial and intermediate approach and 0.5nm for final, missed approach and departure

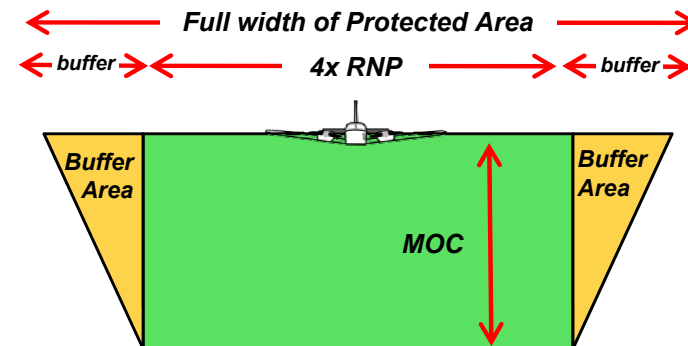

- Fix Tolerance is simply a $1x$ RNP radius around the waypoint

See the Eurocontrol publication “Guidance Material for the Design of Terminal Procedures for Area Navigation”, at http://www.ecacnav.com/downloads/iss3_0.pdf. This is an excellent document, with detailed content on many topics that are only briefly touched upon in this manual. It is well worth downloading and saving as a reference.

How are RNAV Procedures different?

2. Fly-By turn Protected Area is smaller than that of conventional turns

- The Fly-By turn design assumes
 - a fix tolerance of RNP-X (eg. 1nm in P-RNAV)
 - aircraft turn at Rate 1 ($3^\circ/\text{sec}$), up to a maximum bank angle of 25° , whichever is lower
 - a 5 seconds allowance, from the time the aircraft's navigation system computes that a turn should start, for either the pilot or autopilot to react and to establish the appropriate bank angle
- The Fly-By turn design thus uses the same bank angles, fix tolerances, wind effects and pilot/autopilot reaction times as the Fly-Over design. However, the diagrams below illustrate how much *inherently smaller* the Fly-By protected area is with those same safety margins built-in

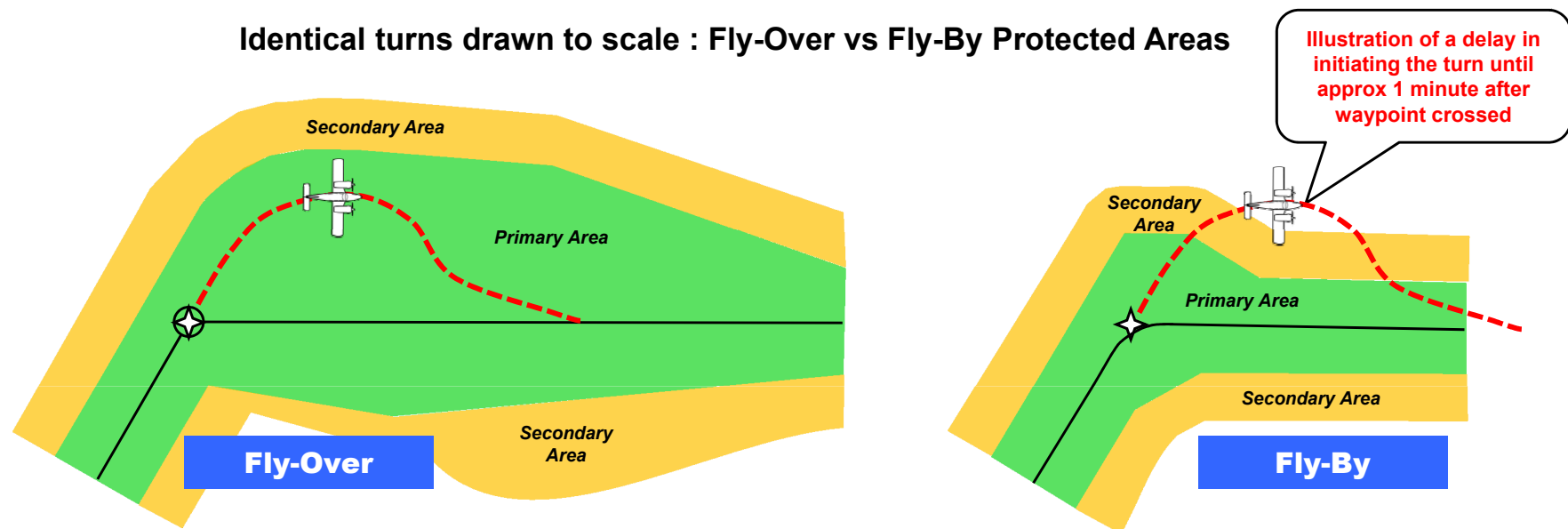

How are RNAV Procedures different?

3. Procedures use only a few of the most “predictable” Path-Terminators

Paths

Terminators

	Fix to	Track from fix to	Course to	Heading to	Direct to	Racetrack	DME Arc to	Radius from fix
Fix	IF Initial Fix	TF Track to Fix	CF Course to Fix		DF Direct to Fix	HF Racetrack to Fix	AF	RF Radius to Fix
Altitude		FA Fix to Altitude	CA Course to Altitude	VA Heading to Altitude		HA Racetrack to Altitude		
Manual Termination		FM Fix to man. term.		VM Heading to man. term.		HM Racetrack to man. term.		
Distance		FC						
DME Distance		FD	CD	VD				
Intercept			CI	VI Course to Intercept				
Radial			CR	VR				
Procedure Turn	PI							

Red: “best practice” RNAV leg types

Orange: RNAV leg types used mainly at the start and end of procedures when required (eg. VA as the first leg of a SID)

Blue: non-RNAV leg types

How are RNAV Procedures different?

4. There is a distinct RNAV procedure “style”

- “Style” features typical of RNAV procedures:

“traditional” Entry Fix

- RNAV STARs start with a conventional Fix, which the pilot should use to cross-check with radio aid raw data to avoid gross errors
- RNAV SIDs require a nav accuracy check on the runway
- RNAV(GPS) approaches may require a user-defined check for gross error, since they often start with a ‘pure’ RNAV waypoint

Use of many Waypoints

- After the initial Fix, all subsequent leg terminators are RNAV waypoints, rather than radio-referenced fixes
- 6-10 waypoints are common in an RNAV arrival procedure, compared to 3-6 fixes in a traditional one

Turns are Fly-by

- Generally, all turns will be Fly-By, with Fly-Over waypoints avoided
- Turns may also use the “Fix to Fix via a Constant Radius” (RF) leg
- Waypoints are spaced far enough apart to allow stable track capture between turns

Legs are TF, except at the start/end of procedures

- TF (and, in the future, RF) legs are used to provide the most predictable flight paths and the most FMS/GPS-“friendly” coding, sequencing and guidance
- By necessity, procedures may start or end with non-TF legs, eg. a SID may begin with VA (Heading to Altitude) then CF (Course to Fix), followed by a TF sequence

Many altitude and speed constraints

- RNAV arrivals, in particular, include more specific altitude and speed constraints than a typical conventional procedure. This is designed to allow efficient traffic flows and descent profiles and reduced radio communications

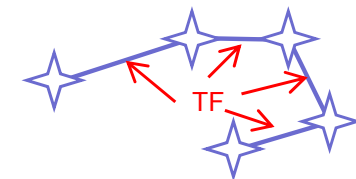
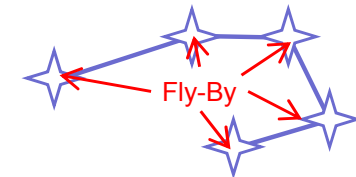

Examples:

<u>3000</u>	“or above”	<u>4000</u>	“between”	<u>2000</u>
<u>3000</u>	“at”	Max IAS	speed limit	220KT
<u>3000</u>	“or below”	IAS	speed target	180KT

How are RNAV Procedures different?

4.RNAV procedure illustration

Example: NEMAX2B trial P-RNAV Arrival to Rwy 27 ILS at Nottingham East Midlands (EGNX)

Extract from UK CAA AIP SUP S1/2008

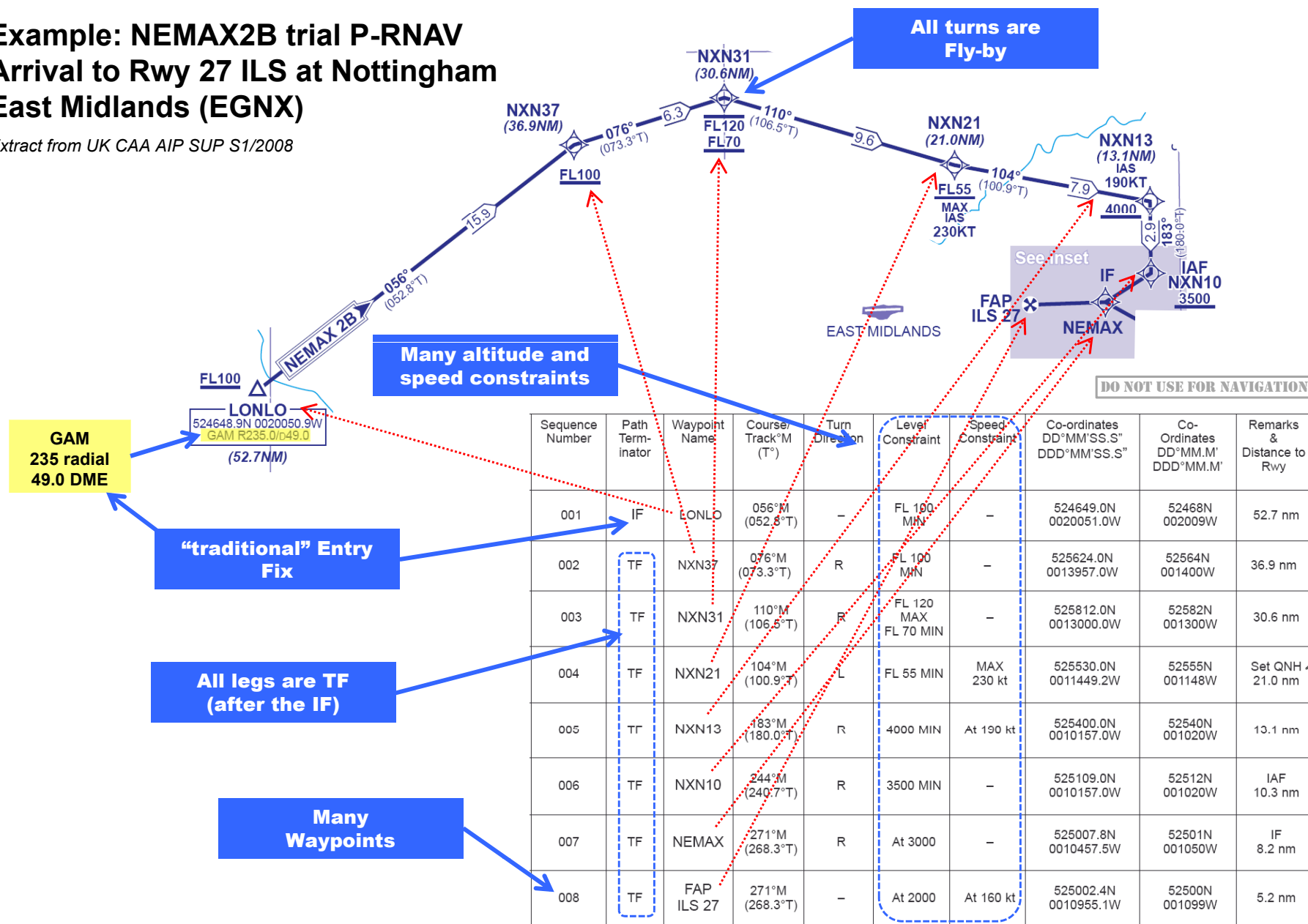

How are RNAV Procedures different?

5. Arrival vertical profile often optimised for jet aircraft “continuous descent”

- Unlike most conventional procedures, RNAV STARs are often “closed”, terminating at the final approach point, rather than an initial or intermediate one (“open”)
- The vertical profile is usually designed to allow jet aircraft to commence descent late and then descend continuously, at 220KIAS and flight idle power, from the start of the procedure until the final approach waypoint and speed. This corresponds to a gradient of approximately 300’ per nm.
 - this is the most efficient and environmentally friendly method, known as CDA (Continuous Descent Approach). Otherwise, for jet aircraft, the earlier descent and power/configuration changes in a “step-down” arrival involve unnecessary fuel burn and a greater noise footprint

Example: Vertical profile of NEMAX1B trial P-RNAV Arrival procedure at Nottingham East Midlands (EGNX)

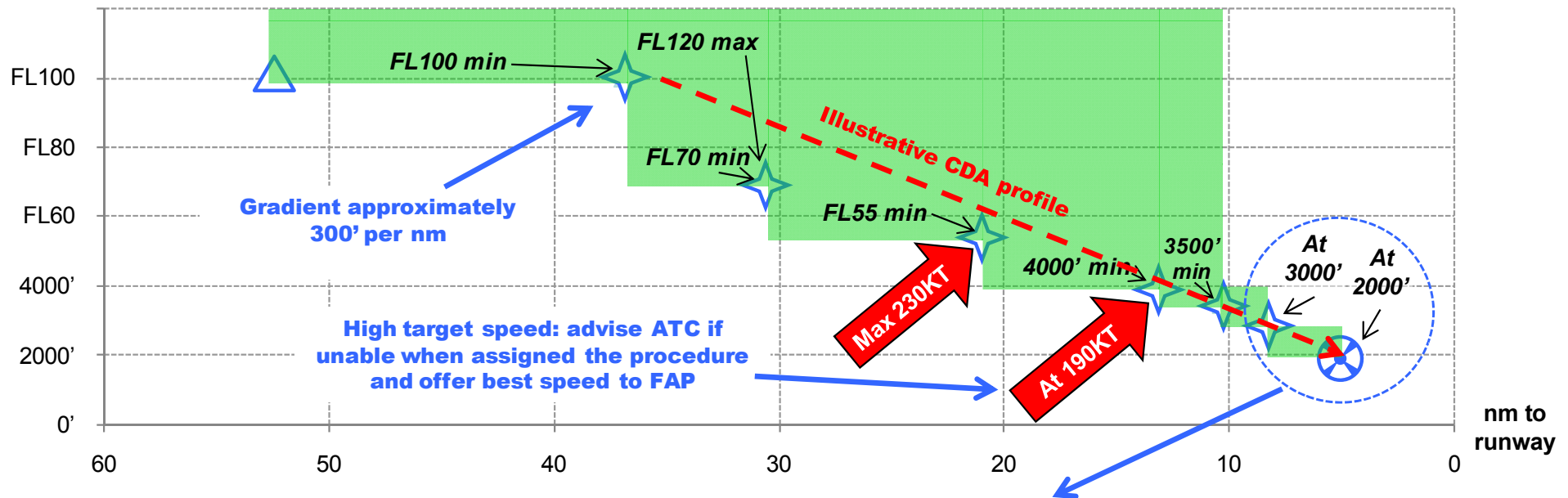

- Note the aircraft performance and pilot workload required during the transition to the final approach
 - descending at ~300’ per nm whilst decelerating from 190KIAS (or speed attainable) to approach speed
 - no distinct level-off available for slowing down
 - cockpit transition of CDI, GPS course guidance and autopilot mode from RNAV to ILS/DME

How are RNAV Procedures different?

Summary

Traditional Procedures

- Execution is demanding
 - selecting, identifying and displaying navaids
 - following track, distance and timing from raw data
 - repeated for each leg
- Management is easy
 - select the right chart and then follow the execution steps

RNAV Procedures

- Execution is easy
 - following the GPS guidance from waypoint to waypoint
- Management is more complex
 - valid database, correct procedure loaded and verified
 - RAIM availability checked; GPS, CDI and Autopilot mode selection
 - avoidance of gross errors and “WIDN?” (what’s it doing now?) confusion with GPS receivers



- The focus of most of the following sections of this course is on the proficient and safe *management* of RNAV flight

1. RNAV and RNP theory
 - a. Introduction
 - b. The Path-Terminator
 - c. RNAV procedure design
 - d. RNP principles**
 - e. RNAV and RNP applications
2. GPS Navigators and their application to RNAV
 - a. The GPS system
 - b. Databases and Coding
 - c. Procedures
 - d. Error detection and warnings
3. P-RNAV Terminal Procedures
 - a. P-RNAV requirements and approvals
 - b. P-RNAV training topics
 - c. P-RNAV operations
4. RNAV(GPS) Approach Procedures
 - a. GPS procedure types
 - b. GPS approach requirements and approvals
 - c. GPS approach operations
5. Avionics training
6. Simulator and/or Flight training

Traditional procedure design

- Standard infrastructure of ground radio aids
- Aircraft carry a standardised suite of navigation receivers and instruments
- Procedure tolerances designed around these standards

RNAV procedures pre-RNP

- Proliferation of different RNAV navigations systems
- Even within one type of aircraft and one make of avionics, a variation in the FMS or GPS software release installed can make an important difference to the system's capabilities for executing a particular procedure
- Procedure design increasingly complex and restricted

RNP procedure design

- Standard performance specifications established: "RNP-X"
- Procedure tolerances designed around these RNP-X standards
- Navigation and autopilot systems certified to RNP-X criteria



- RNP is a 'standard interface' between the complex worlds of IFR airspace and procedure design, avionics and autopilot design/certification and the development of flight training and operating procedures
- The new PBN model aims to further improve upon the benefits of the RNP concept

Definition of RNP accuracy requirement

- There are five main navigation performance criteria:
 1. Accuracy is the difference between the true and indicated position and track
 2. Integrity is the ability to provide timely warnings when the system is not safe to use
 3. Availability is the ability of the total system to perform its function at the initiation of the intended operation
 4. Continuity is the ability of the navigation system to provide its service without interruption during an operation
 5. Vulnerability is the susceptibility to unintentional or deliberate interference
- The key requirement of RNP-X is an accuracy specification expressed as a Total System Error (TSE) of X nm or less for more than 95% of the total flight time
- TSE is defined as follows:

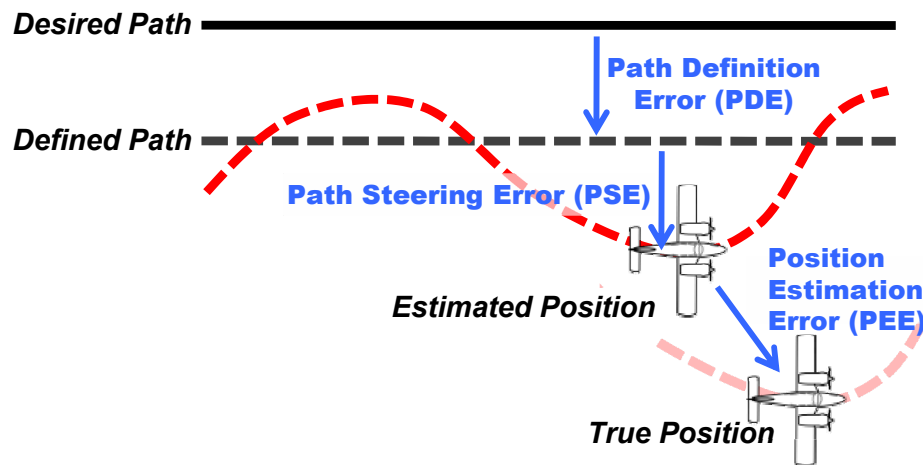

Total System Error (TSE) is the vector sum of

- Path Definition Error (PDE)
- Path Steering Error (PSE)
- Position Estimation Error (PEE)

- Path Definition Error is the difference between the path intended by the procedure designer and the path the aircraft is guided along as a result of database coding and navigator processing
- Path Steering Error is the sum of display error in Nav systems and Flight Technical Error (FTE); ie. the errors in manual flight by pilots or autopilot performance in following a desired path. FTE includes reaction times and wind/turbulence induced errors, it does not include human “conceptual” errors eg. selecting the wrong procedure, waypoint or autopilot mode, or simply turning in the wrong direction
- Position Estimation Error is the combination of navigation system/sensor (GPS) error and computation error (GPS software). PEE is expressed as a 95% confidence radius, called the Estimate of Position Uncertainty (EPU) or Actual Navigation Performance (ANP). PEE is sometimes also called Navigation System Error (NSE)

- In practice, the Path Definition and Position Estimation errors are negligible, the key concerns for the GA pilot are FTE and the human factor errors in selecting RNAV procedures, using GPS units, interpreting guidance and in manual flying or operating the autopilot

The current RNP-X specifications published in Europe (see next section for future PBN specs)

Used for
RNAV(GPS)
Approaches



Used for
P-RNAV



Used for
B-RNAV



RNP Type	Required Accuracy (95% Containment)	Description
0.3	± 0.3 NM	Supports Initial/Intermediate Approach, 2D RNAV Approach, and Departure. Expected to be the most common application.
0.5	± 0.5 NM	Supports Initial/Intermediate Approach and Departure. Only expected to be used where RNP 0.3 cannot be achieved (poor navaid infrastructure) and RNP 1 is unacceptable (obstacle rich environment)
1	± 1.0 NM	Supports Arrival, Initial/Intermediate Approach and Departure; also envisaged as supporting the most efficient ATS route operations. Equates to P-RNAV.
4	± 4.0 NM	Supports ATS routes and airspace based upon limited distances between navaids. Normally associated with continental airspace but may be used as part of some terminal procedures. There are no plans at present to use RNP 4 in ECAC.
5	± 5.0 NM	An interim type implemented in ECAC airspace to permit the continued operation of existing navigation equipment. Equates to B-RNAV.
10	± 10 NM	Supports reduced lateral and longitudinal separation minima and enhanced operational efficiency in oceanic and remote areas where the availability of navigation aids is limited. ⁹
12.6	± 12.6 NM	Supports limited optimised routing in areas with a reduced level of navigation facilities
20	± 20.0 NM	The minimum capability considered acceptable to support ATS route operations.

← US RNAV 1

← Oceanic & remote enroute

← Oceanic

1. RNAV and RNP theory
 - a. Introduction
 - b. The Path-Terminator
 - c. RNAV procedure design
 - d. RNP principles
 - e. RNAV and RNP applications**
2. GPS Navigators and their application to RNAV
 - a. The GPS system
 - b. Databases and Coding
 - c. Procedures and guidance
 - d. Error detection and warnings
3. P-RNAV Terminal Procedures
 - a. P-RNAV requirements and approvals
 - b. P-RNAV training topics
 - c. P-RNAV operations
4. RNAV(GPS) Approach Procedures
 - a. GPS procedure types
 - b. GPS approach requirements and approvals
 - c. GPS approach operations
5. Avionics training
6. Simulator and/or Flight training

Enroute/Terminal

(Basic) B-RNAV

- Requires RNP-5 capable navigation equipment (sufficient condition)
- Compulsory, since 1998, in almost all European airways and TMAs
- Private GA operators can meet requirements through carriage of an approved IFR GPS installation

(for UK registered aircraft, AFM supplement must specify BRNAV approval; for US aircraft, requirements are similar – see AC90-96A Appendix 1)

- B-RNAV SIDs and STARs are implemented which meet en-route design criteria (eg. are above MSA) and which start & end at a conventional fix

(note: both B-RNAV and P-RNAV procedures are designated “RNAV”. Check approach plate detail, airport text pages and AIPs/AICs as appropriate – some RNAV terminal procedures formerly requiring only B-RNAV are migrating to needing P-RNAV approval)

Terminal

(Precision) P-RNAV

- Requires RNP-1 capable navigation equipment (necessary but not sufficient)
- Europe is in the early stages of implementing P-RNAV procedures and all such TMAs currently offer conventional alternatives
- Private GA operators must obtain a Letter of Authorisation from their state of registry. JAA TGL10 and FAA AC90-96A Appendix 2 specify requirements for navigation system function, database approval, pilot training and operating procedures



See Section 3

Approach

RNAV (GPS) Approaches

- Requires RNP-0.3 capable navigation equipment
- Europe is in the early stages of implementing GPS approaches
- Private GA operators requirements for equipment carriage are similar to B-RNAV: (E)TSO C129a or C146a GPS with installation conforming to FAA AC20-138 or EASA AMC 20-5 and AFM approval for Approaches
- National air law generally requires GA pilots to have some theoretical and flight training specific to GPS Approaches



See Section 4

Future RNAV applications in Europe: The new Performance-Based Navigation (PBN) model

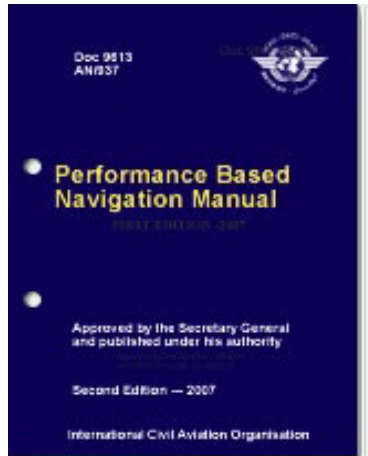

Available from

http://www.ecacnav.com/Document_Library



- PBN is the new formal model of how RNAV is implemented
- It is a move from a limited statement of required performance accuracy (ie. basic RNP-X) to more extensive statements of required performance in terms of accuracy, integrity, continuity and availability, together with descriptions of how this performance is to be achieved in terms of aircraft and crew requirements.
- The Required Navigation Performance (RNP) concept has been replaced by the PBN concept. Therefore, a lot of RNP terminology has been replaced by PBN terminology
- The ICAO 'Performance Based Navigation Manual (Final Draft)' replaces the 'Manual on Required Navigation Performance (RNP) ICAO Doc 9613-AN/937'.
- Global definitions of terms are provided that are aimed at removing any previous regional differences.
- A set of globally compatible Navigation Specifications are also provided. These are to be used as a basis for local or regional Navigation Applications in the en route, terminal and approach environments

Source: the ECACNAV free online course on PBN <http://www.ecacnav.com/WBT/PBN/frames/firstwin1.htm>



- PBN has no current or imminent relevance to European IFR operations. However, because a GA pilot may increasingly encounter the terminology and specification of future PBN applications in various articles and documents, this section provides a brief overview for the sake of completeness and orientation
- This Manual will revert to the current RNAV terminology in sections 2-6, and no further reference to PBN will be necessary

Performance-Based Navigation (PBN) specifications

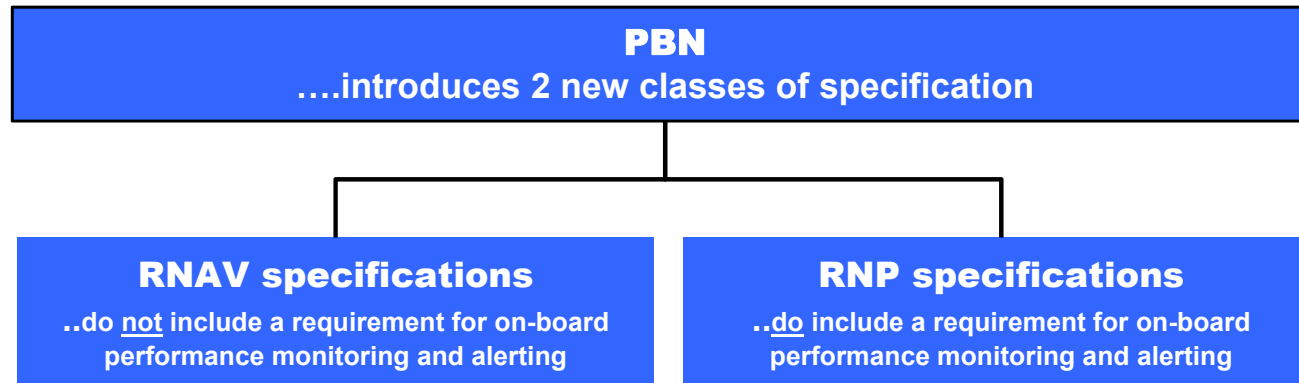

“on board performance monitoring” is not a problematic requirement for modern GPS units

- These are essentially a re-naming of existing specifications with a new RNAV X convention, in which the X is 95% lateral accuracy in nm

<i>Current name</i>	PBN name
<i>RNP 10</i>	RNAV 10
<i>B-RNAV</i>	RNAV 5
<i>RNAV 2 (USA)</i>	RNAV 2
<i>P-RNAV (Europe), RNAV1 (USA)</i>	RNAV 1

- These add some (modest) extra “containment”/alerting requirements to existing RNP specs, and introduce some new applications

PBN name	Used in:
RNP 4	Oceanic
Basic RNP 1 & 2 Advanced RNP 1	Various flight phases
RNP APCH	Similar to RNAV(GPS)
RNP AR APCH	More demanding “Authorisation Required” approaches
RNP “3D”, “4D”	..to be defined

Reference: extract from ICAO PBN Manual

Table 1-1: Application of Navigation Specification by Flight Phase

NAVIGATION SPECIFICATION	FLIGHT PHASE							
	En Route OCEANIC /REMOTE	En Route Continental	ARR	APPROACH				DEP
				Initial	Interm.	Final	MISSED	
RNAV 10	10							
RNAV 5		5	5					
RNAV 2		2	2					2
RNAV 1		1	1	1	1		1 ^b	1
RNP 4	4							
Basic-RNP 1			1 ^{a,c}	1 ^a	1 ^a		1 ^{ab}	1 ^{a,c}
RNP APCH				1	1	0.3	1	
RNP AR APCH				1-0.1	1-0.1	0.3 – 0.1	1-0.1	

Notes:

The numbers given in the table refer to the 95% accuracy requirements (NM)

RNAV 5 is an en-route navigation specification which may be used for the initial part of the STAR outside 30NM and above MSA

RNP 2 and Advanced-RNP 1 are expected to be included in a future revision of the PBN Manual;

1a means that the navigation application is limited to use on STARs and SIDs only;

1b means that the area of application can only be used after the initial climb of a missed approach phase

1c means that beyond 30 NM from the airport reference point (ARP), the accuracy value for alerting becomes 2 NM

The above table shows the navigation specifications and their associated navigation accuracies published in Parts B and C of this Volume. It demonstrates, for example, that the designation of an oceanic/remote, en route or terminal navigation specification includes an indication of the required navigation accuracy, and that the designation of navigation specifications used on Final Approach is different.

Most important, the above table shows that for any particular PBN operation, it is possible that a sequence of RNAV and RNP applications is used. A flight may commence in an airspace using a Basic RNP 1 SID, transit through En Route then Oceanic airspace requiring RNAV 2 and RNP 4, respectively, and culminate with Terminal and Approach operations requiring Advanced RNP 1 and RNP AR APCH.

1. RNAV and RNP theory
 - a. Introduction
 - b. The Path-Terminator
 - c. RNAV procedure design
 - d. RNP principles
 - e. RNAV and RNP applications
2. GPS Navigators and their application to RNAV
 - a. The GPS system**
 - b. Databases and Coding
 - c. Procedures
 - d. Error detection and warnings
3. P-RNAV Terminal Procedures
 - a. P-RNAV requirements and approvals
 - b. P-RNAV training topics
 - c. P-RNAV operations
4. RNAV(GPS) Approach Procedures
 - a. GPS procedure types
 - b. GPS approach requirements and approvals
 - c. GPS approach operations
5. Avionics training
6. Simulator and/or Flight training

The Global Satellite Navigation System (GNSS)

The general term for the global navigation satellite and ground station infrastructure

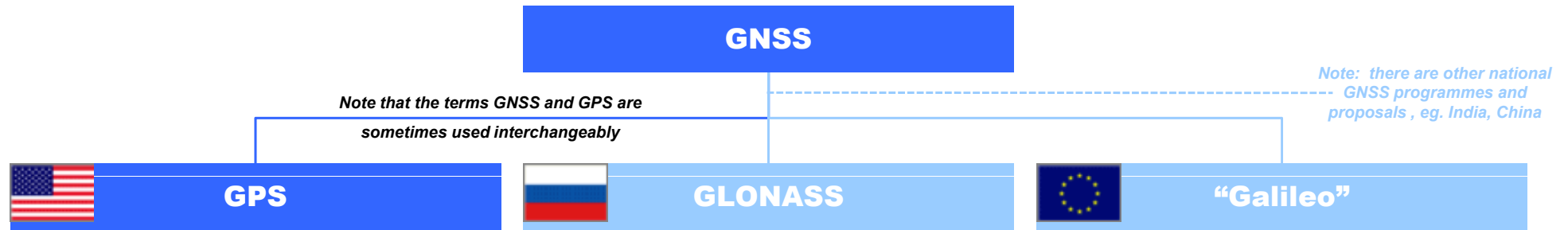

- The USA's "Navstar" Global Positioning System
- A military system that became fully operational for worldwide civilian use in 1995
- Designed around a network of 24 medium-earth orbit satellites
- "Selective Availability" (SA) degradation of civilian signal accuracy ended in 2000

- Russian "Global Navigation Satellite System"
- Introduced during the Soviet era for military applications
- At present, only partially operational, with 13 of 24 required satellites functioning and approx ~60% global coverage
- Russia intends to fully restore GLONASS by ~2011, in partnership with the Indian government

- The European Union's GNSS project
- After some controversy, formally approved in Nov 2007
- Should be operational by ~2013
- USA/EU agreement that Galileo and GPS will be "interoperable"
- Will use a 30 satellite constellation; some service and accuracy improvements over current GPS



- **The concept is that receivers should be able to operate with multiple systems, creating in GNSS a single 'virtual' system capable of providing a high degree of resilience when used as a sole source of navigation data for aircraft**
- **The rest of this manual will refer only to GPS**

How does GPS work?

1. Overview of the system's three "segments"



Space Segment (SS)

- The system is designed for a minimum of 24 satellites (abbreviated as "SV", Satellite Vehicle): 4 in each of 6 orbital planes, at a height of ~20,000km and completing one orbit every 12hrs
- Currently there are 31 satellites, the 7 additional ones improve accuracy and resilience. The constellation is arranged so that at least 6 satellites are always line-of-sight visible from almost any point on the Earth

- *The Master Control Station feeds back a navigational update to each satellite, synchronising its internal clock and adjusting the ephemeris model of its orbit*
- *Occasional maneuvers are commanded which maintain a satellite in its proper orbit*

- *The location of the Ground Stations is very accurately established and used to calibrate the satellites' position and clock data based on the navigation messages they send*

- *Each satellite broadcasts a "ranging code", used to establish distance from the GPS receiver, and its own "Navigation Message" containing*
 - *Clock data at the time of transmission*
 - *Data on the satellite's orbital position ("ephemeris")*
 - *"Almanac" data on the status of the entire satellite network*

(detailed in following pages)



Control Segment (CS)

- A Master Control Station in Colorado and 4 Monitor stations across the globe
- They establish the exact orbital position of each satellite, and maintain the reference atomic clocks for the system



User Segment (US)

- Navigation devices which typically include an antenna, an accurate clock, receiver, processor and control/display components
- Modern 'multi-channel' receivers can simultaneously monitor 12-20 satellites



- **The receipt of ranging codes and navigation messages from multiple satellites allows GPS Receivers to compute accurate 3D position, speed and time**

How does GPS work?

2. The satellites broadcast a signal for civilian receivers called "L1"

The Navigation Message

The Navigation Message consists of 5 subframes of 10x 30bit words (1500bits total) transmitted at 50bits/s, ie. every 30 seconds. See next page for detail.

C/A (Coarse/Acquisition) code

..is the ranging code, used by the GPS receiver to measure distance to the satellite; also called "the "Standard Positioning Service" or SPS

The C/A code is a 1,023bit "pseudorandom number" (PRN) transmitted at 1.023Mbit/s, ie. repeating every millisecond.

The PRN is unique to each satellite, and all the PRNs are stored in GPS Receiver memory. Because they are long pseudorandom numbers designed to be "orthogonal", any two different PRNs will "correlate" poorly (ie. when multiplied together, give a value near zero).

The Receiver isolates any given satellite's transmission by multiplying the incoming L1 signal by that satellite's PRN at different time shift intervals, within the 1 millisecond sequence, until it finds a match or 'lock-on' (when a particular time shift results in a high multiplication value). It can thus "filter out" all the other satellites from the L1 frequency, and use the time shift required for lock-on to calculate the satellite's range and also extract (demodulate) the Navigation Message from the C/A code. See later pages for detail.

L1 Carrier

The Navigation message is encoded onto the C/A code, and the C/A is then modulated on to a carrier frequency of 1575.42 MHz, called "L1"

The fundamental frequency of the system, F_0 , is 10.23Mhz. The carrier and code frequencies are multiples of this, eg. $L1 = F_0 \times 154$. All radio frequencies and codes generated in the satellite are from the same 10.23MHz crystal, controlled by an atomic clock

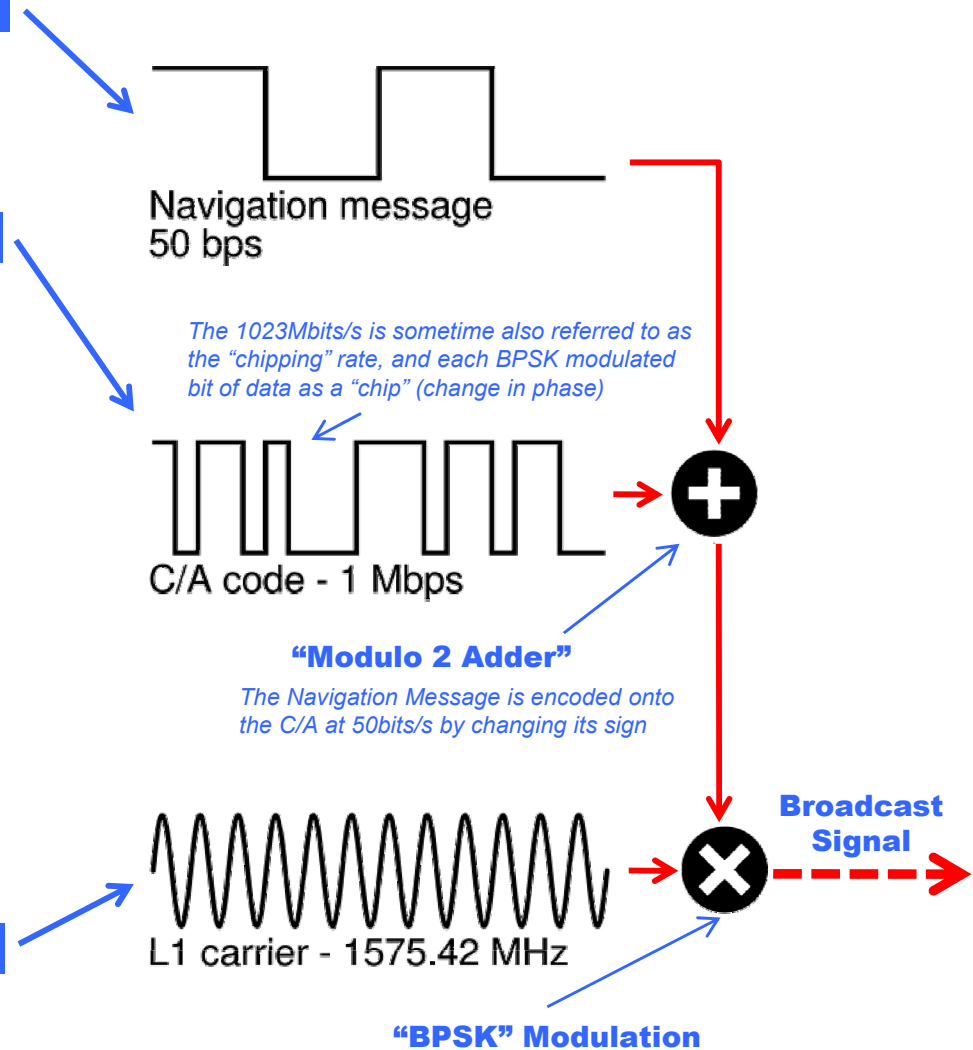

How does GPS work?

3. The structure of the Navigation Message

- The **Navigation Message** is transmitted as a stream of digital data organised into a sequence of **Frames**
- Each satellite begins sending a Frame exactly on the minute and half-minute, according to its internal clock
- Each **Frame** is made up of 5 **Subframes**
 - Subframes 1,2 and 3 are repeated in consecutive Frames and updated every 1-2 hours, on the hour
 - The almanac data in Subframes 4 and 5 is “sub commutated”; it takes a cycle of 25 Frames (with different Subframe 4&5 data) for the receiver to assemble the full almanac
 - The almanac is thus repeated every 25 Frames and is updated approximately every 24hrs
- Each **Subframe** is made up of 10 **Words**
 - Words 3-10 carry the data content of the frame as described above
 - Word 1 is called the “Telemetry” word and contains a sync pattern used by the receiver to synchronize itself with the Navigation Message and thus decode the data content
 - Word 2 is the “Handover” word, analogous to a counter that increments by 1 in each Subframe
- Each **Word** is made up of 30 **Bits** of data

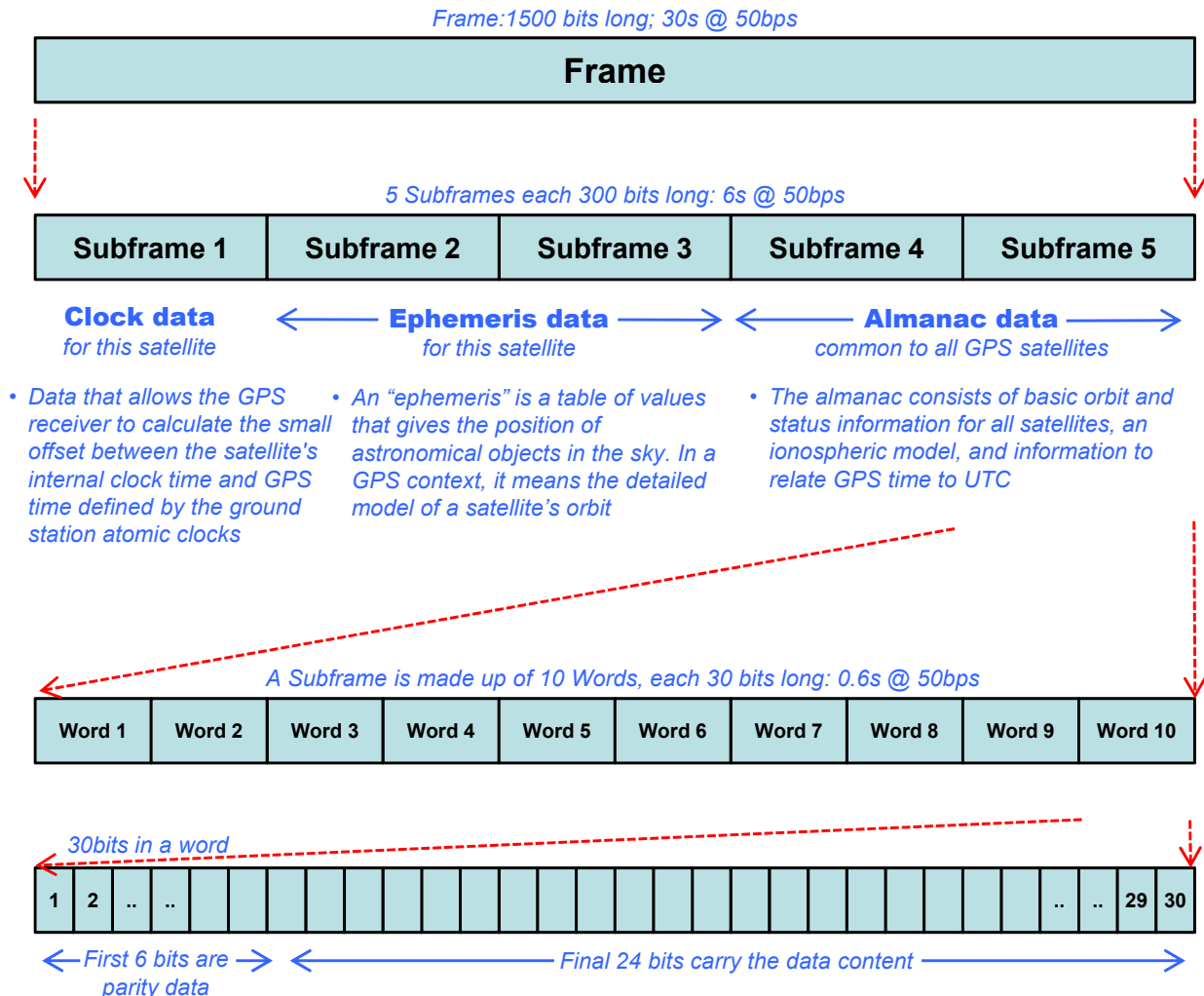

- Data that allows the GPS receiver to calculate the small offset between the satellite's internal clock time and GPS time defined by the ground station atomic clocks
- An “ephemeris” is a table of values that gives the position of astronomical objects in the sky. In a GPS context, it means the detailed model of a satellite's orbit
- The almanac consists of basic orbit and status information for all satellites, an ionospheric model, and information to relate GPS time to UTC



• The Navigation Message is the ‘real-time reference manual’ for the GPS receiver, which helps it calculate an accurate position based on the C/A Code ranging signals

How does GPS work?

4. Other (non-civilian) signals and future enhancements to the system

Non-civilian GPS transmissions

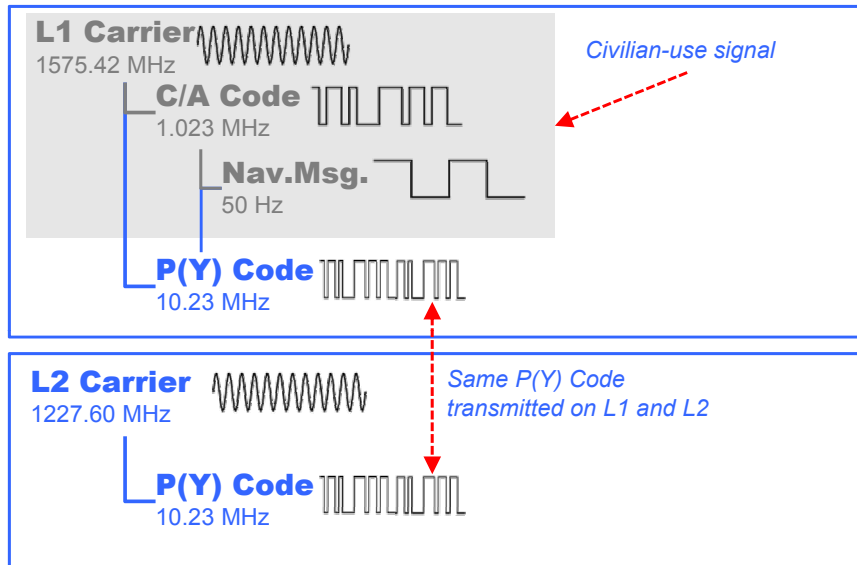

- The P (Precise) code is a 10,230bit psuedo-random number, it is a 10x more accurate version of the C/A code
- Normally, the P code is encrypted by a "Y" code, creating the 10.23 MhZ P(Y) signal which can only be decrypted by military users – known as the "Precise Positioning Service" (PPS)
- The encryption is an "anti-spoofing" technique ,which provides some assurance that the signal received is not being sent by a non-GPS "spoofing" transmitter. The C/A code is potentially vulnerable to such spoofing.
- The ionosphere delays or "disperses" radio signals differently according to their frequency. Military (and some specialised civilian) receivers can compensate for this by comparing P(Y) signal reception between the L1 and L2 carriers.

Future enhancements

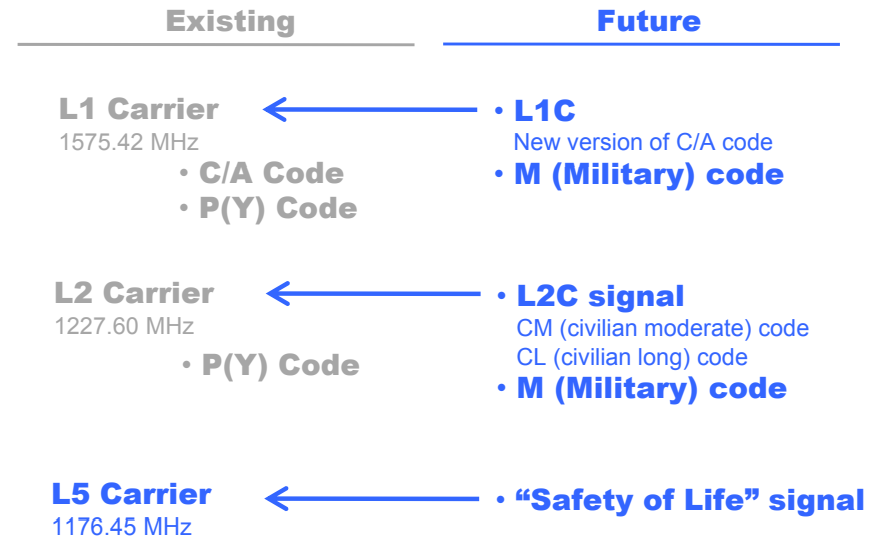

- These new signals are being implemented progressively by new satellite launches over the next 5 years
- L1C will be compatible with existing receivers but include better interoperability with other GNSS systems and other improvements
- L2C is the more accurate "v2.0" civilian GPS signal and allows civilian ionospheric compensation through comparison of L1C and L2C signals
- The M code is the improved military signal
- The L5 "Safety of Life" signal is specifically for civil aviation use and is transmitted in the protected Aeronautical Radio Navigation Services (ARNS) band
- *Author's note: Existing GPS receivers will be supported for very many years. It is likely that after ~2013, some RNAV applications will begin to require new GPS receivers, capable of using the more accurate signals and multiple GNSS systems*

How does GPS work?

5. International time and the GPS time system

International Atomic Time (TIA)

- The standard international scientific time scale
- The length of a second is defined by a frequency property of the cesium-133 atom, and atomic clocks are used to “count” or “accumulate” seconds
- TIA is derived from 230 atomic clocks in 65 sites around the world, and 11 different laboratory caesium frequency standards
- The data is collated by the BIPM (Bureau International des Poids et Mesures) in Paris, who calculate TIA and promulgate the results to various international centres

Universal Coordinated Time (UTC)

- “Earth time” (“UT1”) defines the earth’s angular position with respect to the celestial sphere; this is the most useful time scale for navigation and astronomy
- Fluctuations in the earth’s spin mean that UT1 deviates from the precise TIA reference
- UTC, the “official world time” is a compromise between Earth time and TIA; it uses the TIA second, but introduces leap seconds to account for changes in the earth’s spin and maintain a useful consistency with UT1
- At any given time, UTC equals TIA minus an integer number of seconds. In January 2008, UTC was 33s behind. Typically, a leap second is subtracted once a year

“GPS Time”

- The GPS system uses a time reference (“GPS Time”) maintained by the Master Control ground station’s atomic clocks
- GPS time uses the TIA second, and was set equal to UTC in 1980. It does not introduce leap seconds, and today is 14s ahead of UTC (the difference between TIA & UTC was 19s in 1980, hence today’s 33s-19s=14s). The Navigation Message transmits a correction for UTC, so that GPS receivers can display UTC and local time zones.
- Each satellite carries its own atomic clock, which will have a small error or “offset” from GPS Time. This is known as SV (Satellite Vehicle) time
- SV clock offset information is broadcast in each satellite’s Navigation Message
- The GPS “calendar” is a counter of weeks and days of the week. ‘Date zero’ was 6 January 1980



- **Time measurement is the basis for GPS navigation, because the range from a satellite to a receiver can be determined by the time delay in receiving a signal, and with multiple range fixes, a position can be calculated**

How does GPS work?

6. The GPS Receiver: Overview

Simplified GPS receiver diagram (not Garmin specific, photos are illustrative)

- The antenna is designed to provide equal sensitivity to all satellite signals above (typically) 5 degrees of elevation, and is shielded from lower elevation signals to avoid “multi path” error (reflections from terrain or from the airframe)

- Preamplifier: amplifies the Radio Frequency (RF) signal and sets the noise level to reject other RF interference
- Down Converter: converts the RF signal to an Intermediate Frequency (IF)

- A modern multi-channel receiver simultaneously detects and processes signals from all visible satellites
- Locks on to the PRN code and extracts the Navigation message
- Calculates the relationship between GPS time and Receiver time
- Determines position and velocity (method described on next page)

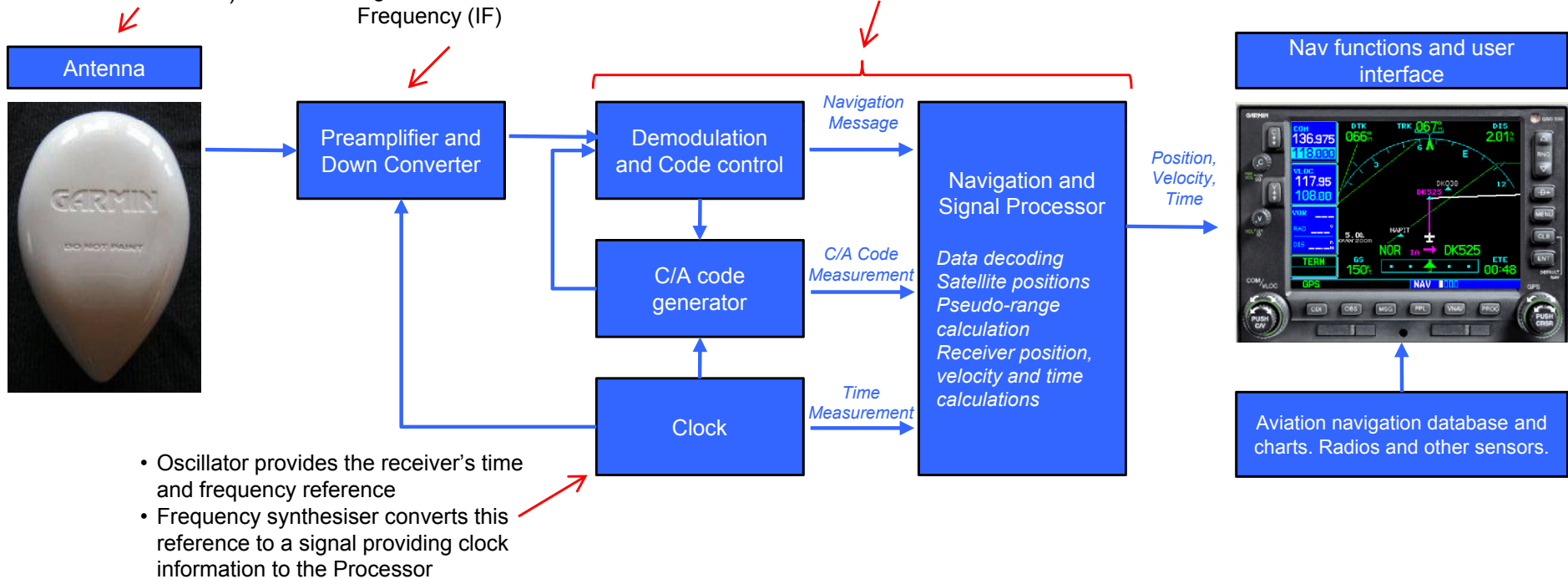

- Oscillator provides the receiver's time and frequency reference
- Frequency synthesiser converts this reference to a signal providing clock information to the Processor



• **The Navigation processor's task is complicated, because the GPS receiver has no accurate time or position reference other than the satellite signals it decodes. These specify the exact “GPS Time” of *transmission* – but the receiver doesn't directly “know” its own GPS Time of *reception*. The calculation method is described on the next page.**

How does GPS work?

7. The GPS Receiver: Calculation of time and position

Stage 1: The “pseudorange”



Stage 2: The accurate fix

- When the GPS receiver is started-up, its internal or “local” clock will be inaccurate by an unknown error, called clock *bias* or *offset*, compared to the reference GPS Time
- A modern quartz clock may be accurate to one part in a million (ie. drift by one microsecond every second). This means that after only 1s, the internal clock error can be the equivalent of hundreds of metres ($1\mu\text{s} = \sim 300\text{m}$ at the speed of light). A unit that’s been switched off for a week or two could be inaccurate by $\sim 1\text{s}$ or hundreds of thousands of km.
- The first stage of the navigation problem is to calculate “pseudoranges” from the visible satellites to the GPS, ignoring the local clock offset. These ranges are “pseudo” because they are all known to be wrong by the same (unknown) local clock error
- For any given satellite, the Receiver generates the satellite’s PRN code internally, based on its “code book”, and starts the code sequence at the time its local clock says the satellite should have started its PRN transmission. The internal PRN code is then time-shifted until it matches (locks-on) to the PRN code signal from the satellite. This time-shift, or *offset*, is the (pseudo) elapsed time between transmission and the reception Time of Arrival (TOA)
- The Pseudorange is derived from the TOA, assuming a given speed for radio wave travel and the decoded time of transmission from the satellite
- The 1023 bit PRN code is transmitted at 1000 times per second, and the Receiver can judge the “start” of a bit to about 1%, so the maximum accuracy of the C/A code is $\sim 3\text{m}$
- By decoding the Navigation Message, the Receiver gets data that allows it to correct Pseudorange for the following errors
 - The SV (Satellite Vehicle) time offset from GPS time
 - Basic ionospheric corrections from the Almanac
 - Relativistic effects and receiver noise
- The Receiver calculates pseudoranges from different satellites simultaneously, so they are all subject an identical local clock error
- The Receiver then uses the ephemeris (orbital) data in each satellite’s Navigation Message to establish the satellite’s position in space at the time of the Pseudorange calculation
- It requires a minimum of 4 satellite pseudoranges to determine a 3D navigational fix for the Receiver.
- The GPS system specification is that 5 satellites should always be available above a mask (elevation) angle of 7.5 degrees (usually it is 6 or more)
- With 4 satellite positions known and 4 pseudo ranges calculated, the navigation problem can be expressed as 4 equations with 4 unknowns (the unknowns being the x,y,z position of the receiver and t, the clock bias error)
- The Receiver calculates a solution to these equations and establishes a position fix
- With true (rather than pseudo) ranges, it would only require 3 satellite position spheres to determine a fix intersect. However, with pseudoranges, a 3 sphere solution would give the wrong range. 4 pseudoranges spheres won’t intersect at a point – because the ranges are not true and consistent with a single point in space. The receiver, in effect, solves the equations to determine which value of local clock error creates the best intersect of the 4 spheres
- The receiver also calculates a Geometric Dilution of Precision (GDOP), based on the relative position of the satellites (satellites close together provide a weaker fix)
- When more than 4 satellites are available, modern receivers use various other algorithms to provide a better fix
- Finally, the x,y,z position from the centre of the earth is translated into latitude, longitude and altitude using the WGS84 datum, and GPS Time is converted into UTC. (See later pages on WGS84)
- Velocity (ie. ground speed and ground track) is calculated using a combination of rate of change of position and Doppler shift measurement of the L1 carrier frequency of different satellites, compared to the receiver’s L1 oscillator frequency

How does GPS work?

8. Illustration of the GPS navigation calculation

Stage 1: The "pseudorange"

Sample of the C/A PRN codes

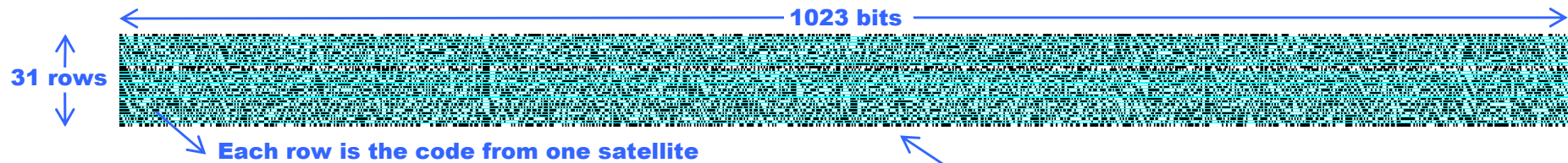

The Receiver generates the C/A PRN code for the satellite it is trying to lock on to....



...and seeks a time-shift that will provide the best correlation between the L1 C/A signal and the internally generated code

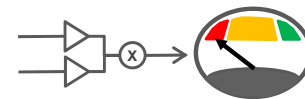
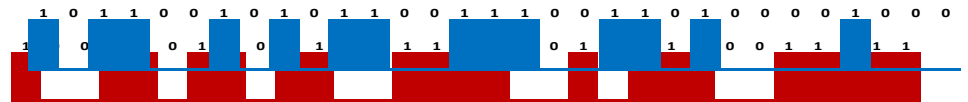

• Low correlation: wrong PRN code

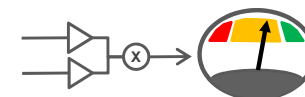
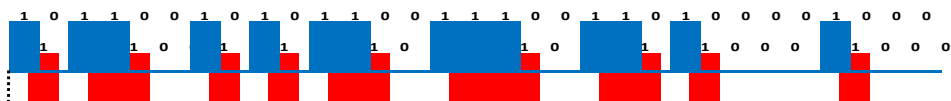

• Better correlation: correct PRN code, but time shift wrong

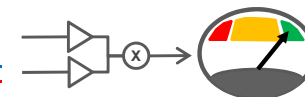
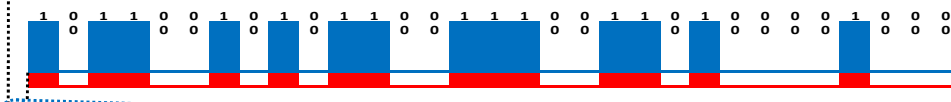

• Best correlation: correct PRN code and best time shift

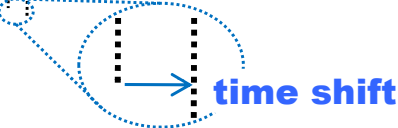

- All 31 satellites use the same L1 carrier frequency to transmit their C/A codes using the Code Division Multiple Access (CDMA) method of multiplexing that allows them to "share" the same carrier.
- A particular C/A code can be extracted from the "noise" of 31 superimposed signals by multiplying the inbound carrier with the desired PRN code generated internally, and time-shifting the internal PRN until a correlation "spike" is achieved
- A full description is beyond the scope of this course. The diagrams are illustrative rather than technically rigorous

How does GPS work?

9. Illustration of the GPS navigation calculation

Stage 2: The accurate fix

Two dimensional illustration of the GPS navigation calculation

Determining pseudorange from 3 satellites results in 3 equations with 3 unknowns: the x,y position of the receiver and t, the local clock bias



The navigation processor solves these equations to determine a clock bias which gives the best intersect between the three bias-adjusted "true" range arcs

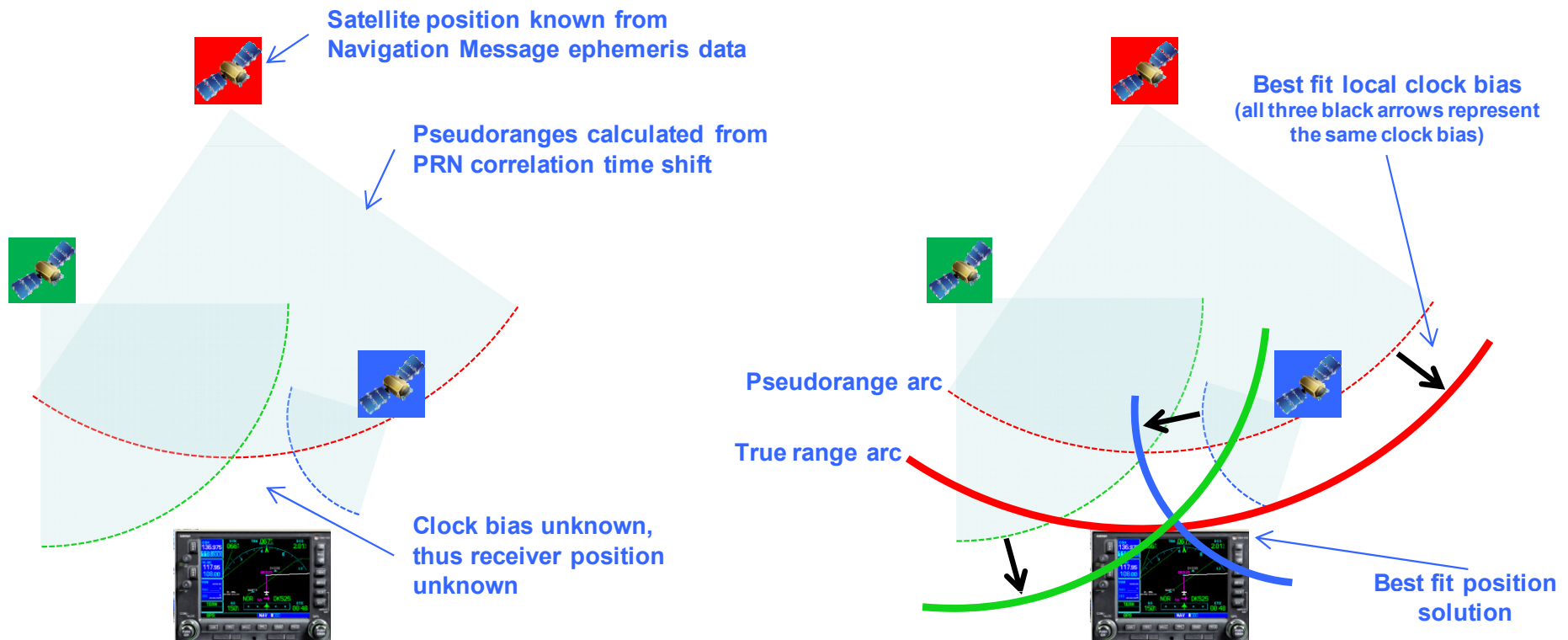

• The actual method used is analogous to this; 4 satellites provide 4 range spheres, and thus 4 equations to solve for the unknown 3D x,y,z position of the receiver and its clock bias

How does GPS work?

10. The WGS84 map datum

What is WGS84?

- Geodesy (or geodetics) is the science concerned with the study of the geometric shape and size of the earth. It defines the coordinate systems and references used in surveying, mapping, and navigation. Typically, such systems have 3 elements:
 - a “Cartesian” reference or datum, defining the origin as the centre of the earth’s mass and the x,y,z axes in terms of polar, equatorial and prime meridian planes
 - an “Ellipsoidal” datum for latitude and longitude; based on the Cartesian datum and an ellipsoid model of the earth’s surface
 - a “Geoid” datum for elevation, determined by local variations in the earth’s gravity, which represents Mean Sea Level and differs from the idealised ellipsoid (“geoid undulation”). See later page on GPS and VNAV.
- Many different global, regional and national geodetic systems are used for different applications. National mapping coordinate systems tend to use a “local” ellipsoid model of the earth’s surface, which is a more accurate mathematical approximation for a particularly country than any global ellipsoid.
- In 1960, the US Department of Defense combined the different global reference systems used by the US Navy, Army and Air Force into a standard “World Geodetic System” known as WGS60. As terrestrial and space survey data improved, and working with scientists and institutions from other countries, the DoD published improved datums in 1966, 1972 and 1984 (WGS66, WGS72, WGS84).
- **WGS84 was selected as the Datum for the GPS system**, and is now a fixed standard; minor subsequent updates have had no practical impact
- Countries continue to use national coordinate systems, although some have changed theirs to conform more closely to WGS84. **However, there can be differences of hundreds of metres between WGS84 maps and other, relatively modern, national and regional maps.** For example, the UK’s Ordnance Survey grid (OSGB36) meridian is 6m west of the historical meridian monument at Greenwich and the WGS84 meridian is 103m east of it

Definition of WGS84

- From the Eurocontrol WGS84 Implementation Manual:
- *The World Geodetic System - 1984 (WGS 84) coordinate system is a Conventional Terrestrial System (CTS), realized by modifying the Navy Navigation Satellite System (NNSS), or TRANSIT, Doppler Reference Frame (NSWC 9Z-2) in origin and scale, and rotating it to bring its reference meridian into coincidence with the Bureau International de l’Heure (BIH)-defined zero meridian.*
 - Origin and axes of the WGS 84 coordinate system are defined as following:
 - Origin: Earth’s centre of mass
 - Z axis: The direction of the Conventional Terrestrial Pole (CTP) for polar motion, as defined by BIH
 - X axis: Intersection of the WGS 84 reference meridian plane and the plane of the CTP’s equator, the reference meridian being the zero meridian defined by the BIH
 - Y axis: Completes a right-handed, Earth Centred, Earth Fixed (ECEF) orthogonal coordinate system, measured in the plane of the CTP equator, 90° East of the x-axis
- *WGS 84 is an earth-fixed global reference frame, including an earth model defined by the shape of an earth ellipsoid, its angular velocity, and the earth-mass which is included in the ellipsoid of reference.*

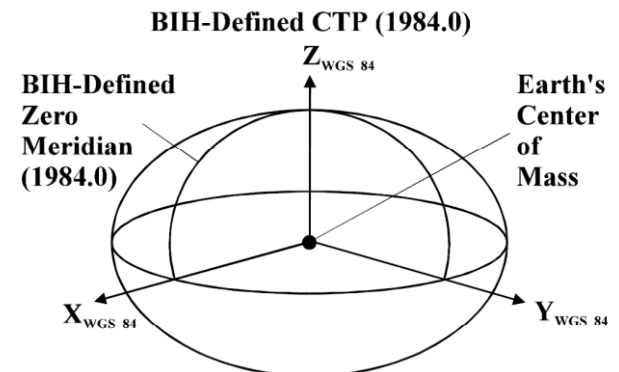

How does GPS work?

11. Aviation charts and WGS84

Aviation charting datums

- Aviation charts use 3 types of position data
 - Surveyed positions for topographic and terrain features, navaid positions and physical references, like runway thresholds
 - Declared positions, defined by latitude and longitude (rather than any surveyed point) for airspace boundaries and oceanic entry/exit points
 - Calculated points, defined by a geometric relationship to a surveyed position (eg. a fix based on a VOR/DME radial and distance)
- RNAV waypoints are either calculated relative to navaids or at declared latitudes and longitudes (although, of course, charts will often show both the navaid reference and the lat/long of a waypoint)
- Historically, each country used its own geodetic datum for aviation charts. Navigating with ground-based aids, an aircraft could fly between countries that used datums hundreds of metres apart without any problem, since IFR terminal and approach charts used in the cockpit were published with the appropriate local datum
- However, work in Europe on radar and navaid trajectories in the 1970s demonstrated the inconsistency of national datums. For example, an aircraft could appear on one country's radar exactly at the declared longitude of an airspace boundary and 1km away from it on an adjacent country's radar

- ➔ • **In 1989, ICAO adopted WGS84 as the standard aviation geodetic reference system**
- **This has been fully implemented in Europe and North America; so that GPS-derived WGS84 positions, approved electronic charts used in GPS receivers and approved paper-based aviation charts are self-consistent**

GPS Navigators and WGS84

- The source of approved aviation GPS navigation and map data are the ICAO-compliant charts published in national AIPs.
- These are encoded into electronic databases and maps using the ARINC 424 standard; proprietary standards may also be used for additional features like terrain and obstacle data and the electronic depiction of paper charts
- **Aviation GPS receivers establish the aircraft's position in terms of the WGS84 datum. The aircraft position is then used as the reference for the GPS navigation and map display**
- In “map display mode”, objects such as waypoints, ground features and airspace boundaries are displayed on the map relative to the aircraft WGS84 position – based on the objects' stored WGS84 coordinates. Navigation data (eg. track and distance to waypoint, cross-track error) is also calculated from the relative WGS84 co-ordinates of the aircraft and the waypoint or flight plan track.

- **In most aviation GPS Receivers, the WGS84 datum can not be changed**

- In non-aviation GPS, the datum may be changeable (eg. to be consistent with maps used for hiking or marine navigation)

Example from Garmin GNS530 Pilot's Guide

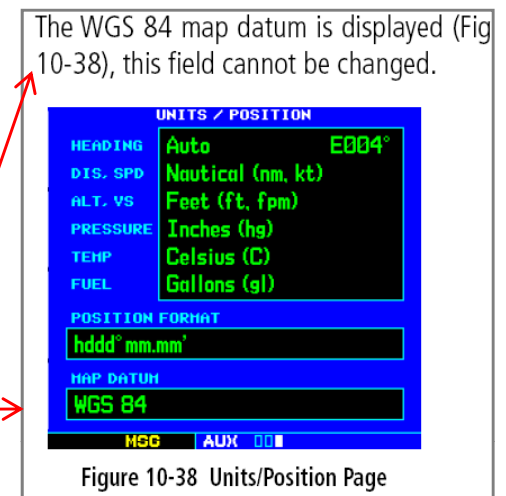

Note: see <http://www.jeppesen.com> ..Online Publications..IFR Pilot Information for an online status report of countries whose AIPs conform to WGS84

Source: ibid, WGS84 Implementation Manual

How does GPS work?

12. GPS mapping illustration

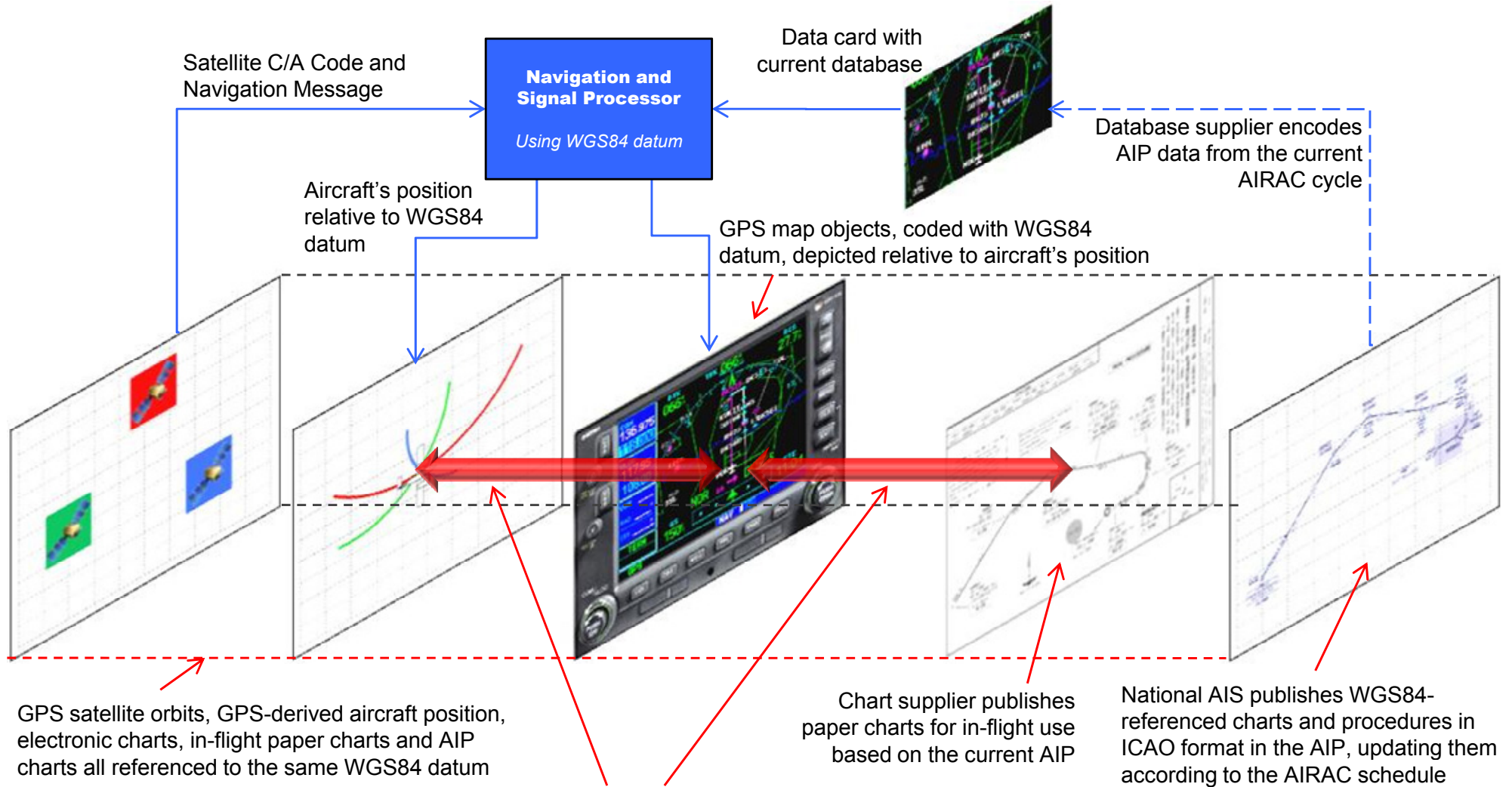

- The use of current, approved WGS84 charts and databases assures the consistency of GPS navigation with radio aids, paper charts and surveyed airport, terrain and obstacle positions
- If non-approved, non-WGS84 or outdated charts or data are used, inconsistencies may arise that could exceed the protection designed into IFR routes and procedures

Definition of the “geoid” and Mean Sea Level

- The reference ellipsoid (global or local) for mapping datums is necessarily a geometric shape – so that latitude and longitude lines may be perfectly regular
- Measures of elevation (or, in aviation terminology, altitude) also need a datum; which, by convention, is Mean Sea Level (MSL). This is both a vertical reference *to measure from* and a (gravitationally defined) direction of up and down *to measure along*
- Climactic, tidal, weather, current and local topographic effects cause the sea level to fluctuate. At any given point, the actual sea level may be measured over time to determine its mean. However, measured mean sea levels do not fit well with any ellipsoid model of the earth - because of the gravitational effect of irregularities in the earth’s shape and composition (eg. variations in the density of the earth’s crust).
- In effect, where gravity is locally “stronger”, MSL will be higher. Why?
 - water flows downhill under the influence of gravity. A still body of water will establish a surface which, at all points, is perpendicular to the “down” direction
 - in a perfect, ellipsoid planet of uniform density, “down” would always be towards its geometric centre. In the case of an irregular body like the earth, the gravitational “down” direction varies locally, rather than always pointing to the earth’s centre of mass. Hence, the global MSL datum is an irregular *surface of gravitational “equipotential”*. At any point on this surface, a plumb line or spirit level (simple devices for identifying local, gravitationally “true” down) would indicate a down perpendicular to the surface.
- A “geoid” is the representation of the earth whose surface has the property of gravitational equipotential and is used as the reference for the Mean Sea Level datum
- The distinction between the geoid and the ellipsoid model of the earth is a significant one – MSL across the world can vary by 100m from the WGS84 ellipsoid.
- The geoid used in WGS84 is called EGM96 (Earth Geodetic Model 96), most aviation GPS receivers use this model to transform the Ellipsoid height coordinate into an altitude above MSL

Aviation vertical navigation

- In aviation, *altitude* is measured from an MSL datum and *pressure altitude* is measured from the ISA pressure datum of 1013.25 hectopascals
- In an aircraft, a barometric altimeter is used to indicate
 - pressure altitude, directly, when set to 1013mb or 29.92” Hg
 - altitude, indirectly, by using a local pressure setting (QNH) that approximates to the MSL datum
- Under ICAO, the WGS84 datum is widely used as the standard for lateral navigation (LNAV). There is no corresponding standard datum for Mean Sea Level in vertical navigation (VNAV). Aviation charts and procedure designs tend to be based on a local MSL datum
- Using barometric altimetry, these variations in MSL datum are not observable to the pilot, because QNH is always referenced to the local MSL datum used for charts and procedures
- **Although modern aviation GPS receivers can display an altitude derived from GPS position data and referenced to EGM96 Mean Sea Level, this can vary significantly from the local MSL datum**

➔ **Thus, all IFR VNAV uses barometric altimetry, not GPS altimetry**

Example, from the Garmin GNS530W Pilot’s Guide



WARNING: *The altitude calculated by the 500W-series is geometric height above mean sea level and could vary significantly from altitude displayed by pressure altimeters in aircraft.*

- Terrain warning systems also use Radar and GPS altitude inputs to avoid depending on the manual setting of QNH

GPS System Performance

1. A model of GPS performance measures and factors affecting them

	Accuracy	Integrity	Availability	Continuity	Vulnerability
Definition	the difference between true and indicated position	the ability to provide timely failure warnings	the ability to perform at the initiation of use	the ability to perform without interruption	susceptibility to unintentional or deliberate interference
GPS System and Satellite Signal	<ul style="list-style-type: none"> Ephemeris error SV clock error Ionospheric error Tropospheric error Multipath error Dilution of Precision Signal noise 	<ul style="list-style-type: none"> Ground monitoring of the Space segment and provision of RAIM data in the Almanac 	<ul style="list-style-type: none"> Satellite coverage Satellite reliability Terrain masking <p><i>situation where terrain creates a mask angle greater than the 7.5 degrees the GPS constellation model is designed to provide coverage for</i></p> <ul style="list-style-type: none"> System is unaffected by number of users 	<ul style="list-style-type: none"> Spoofing potential <ul style="list-style-type: none"> Civilian GPS is vulnerable to 'fake' transmissions from 'spoofing' equipment 	
GPS Receiver	<ul style="list-style-type: none"> Receiver noise Receiver processing error Receiver display error 	<ul style="list-style-type: none"> Receiver RAIM prediction and monitoring <i>(see Section 2d on RAIM and FDE)</i> Other receiver alarms and alerts 	<ul style="list-style-type: none"> Reliability of receiver hardware, software and antenna Quality of installation and power supply 	<ul style="list-style-type: none"> Receiver FDE Reliability of receiver hardware, software and antenna Quality of installation and power supply Dynamic masking 	<ul style="list-style-type: none"> Installation vulnerability to RF interference
GPS Database	<ul style="list-style-type: none"> Coding error 	<ul style="list-style-type: none"> Quality assurance by database supplier 	<ul style="list-style-type: none"> Completeness of database Delivery method for updates 	<p>↑ <i>masking or attenuation of a satellite signal through aircraft motion (eg. wing blocks the signal path in a bank)</i></p>	
Pilot input and interpretation	<ul style="list-style-type: none"> Flight Technical Error User "conceptual" error 	<ul style="list-style-type: none"> Use of RAIM tools 	<ul style="list-style-type: none"> Database updating 	<ul style="list-style-type: none"> Inadvertent mis-operation 	

GPS System Performance

2. Sources of accuracy error in GPS

	Accuracy	Nature of error	Size of error
GPS System and Satellite Signal	• Ephemeris error	• Satellite orbits, although precisely positioned, can deviate from the ephemeris model data transmitted in the Navigation Message	2.5m
	• SV clock error	• Satellite clock errors are monitored by the Ground Segment and corrections are included in the Navigation message. These aren't "real-time" and a small residual error can develop	2m
	• Ionospheric error	• Inconsistencies in how the ionosphere disperses radio signals can only be partially compensated for by the model data in the Almanac – this is the largest single source of error in civilian GPS	5m
	• Tropospheric error	• Different concentrations of water vapour in the atmosphere cause an inconsistency in how radio waves are refracted. This error is small, but can not be easily corrected by modelling or calculation	0.5m
	• Multipath error	• In ground-based applications, a satellite signal may arrive at a receiver via a reflection from a building or terrain. This type of error is inherently less present in most phases of flight, although it is an issue for future precision approach systems	-
	• Dilution of Precision	• Like any position line fix, GPS accuracy is reduced if satellites are close together or very far apart. The total effect is called "Geometric Dilution of Precision" (GDOP). It is also expressed as Horizontal, Vertical, 'Position' (horizontal and vertical) and Time dilution: HDOP, VDOP, PDOP and TDOP • Dilution of Precision multiplies errors from the other sources	-
	• Signal noise	• The result of signal noise compromising the accuracy of the PRN code received	1m
GPS Receiver	• Receiver noise	• The result of noise in the receiver further compromising the accuracy of the decoded PRN	1m
	• Receiver processing error and display error	• Not operationally significant, unless there is a failure or software bug. Unlike an Inertial system, whose estimated position drifts away from true position over time, GPS is continuously updated and does not suffer from systematic "map shift" error	-



• The "User Equivalent Range Error" (UERE) in civilian GPS is better than 35m horizontally and 75m vertically 95% of the time. In practice, the accuracy is significantly better almost all of the time.

GPS System Performance

3. GPS performance model: a practical risk assessment from a pilot's perspective

(applies only to IFR-approved aircraft installations)

	Accuracy	Integrity	Availability	Continuity	Vulnerability
GPS System and Satellite Signal	Very low risk of system or accuracy failures that are not identified by a Receiver RAIM or Loss of Integrity alert		At the <u>system</u> level, very low risk of a loss of service not predicted by RAIM tools At the <u>local</u> level, terrain and satellite geometry surveying is part of the RNAV procedure design process and thus a very low risk of local availability or continuity problems		
GPS Receiver	Very low risk of design problems with TSO/ETSO certified hardware and software		Approved installations have proven highly reliable in millions of hours of service. Of course, like all radio aids, they depend on aircraft power		
GPS Database	Generally highly reliable. However, in the current phase of rapid deployment of RNAV (both new procedures and approaches and <u>new designs</u> of procedure and approach) some extra caution is warranted in checking GPS nav data against paper charts. Use of unapproved or expired databases presents a distinct risk				
Pilot input and interpretation	<p>➡ The major risk is pilot error in operating and interpreting GPS navigation equipment</p>				

Note: these "green" risks are not zero, and regulations thus require alternative procedures and facilities to be available for many GPS applications

➡ Just as in conventional IFR, the human factor risks in using GPS equipment can be safely managed through pilot training, currency and adherence to Standard Operating Procedures

Ground-based Augmentation Systems (GBAS)

- The principle of GBAS is also called “Differential” GPS
- Many of the most significant errors in basic civilian GPS are common to 2 receivers in the same geographical area (eg. Ephemeris, SV clock & Atmospheric errors, Signal noise and GDOP)
- A reference GBAS ground station, whose position is very accurately surveyed, can calculate a correction for such errors which can be broadcast to nearby stand-alone GPS receivers.
- The resulting correction can improve the User Equivalent Range Error by a factor of 20x: from 35m horizontal and 75m vertical to 1m horizontal and 2m vertical

Differential GPS (DGPS)

- Differential GPS (DGPS) systems originated in the time before “Selective Availability” was permanently switched off by the US DoD and civilian GPS accuracy was ~100m. This proved inadequate for safe marine navigation and, in the late 1990s, the US Coast Guard implemented a DGPS system in US waters. Similar systems were developed in Europe, partly also to replace the defunct Decca marine navigation system

Local Area Augmentation System (LAAS)

- An aviation application designed to provide precision approach capabilities to CAT III Autoland levels of accuracy and integrity
- “Local” in the sense that reference receivers are around a single airport at precisely surveyed locations. The system calculates a differential correction which is transmitted via a VHF data link. The LAAS Receiver on board an aircraft can then create a ‘synthetic’ ILS display
- First-generation LAAS proved more expensive and not significantly more accurate than WAAS. However, future versions will be used as CAT II and III precision approach aids, to improve on the CAT I limit of WAAS

Satellite-based Augmentation Systems (SBAS)

- SBAS uses the same principle as GBAS (differential corrections derived from ground-based stations) to achieve ~2m accuracy
- The system is implemented by
 - a network of Reference Stations providing regional/continental coverage
 - a Master Station which collates their data, calculates a differential correction for each satellite in the GPS constellation being tracked and prepares a SBAS broadcast
 - a Ground Earth Station that uplinks the broadcast to a geostationary satellite
 - the geostationary satellite broadcast of SV corrections as an additional C/A code on the L1 frequency
 - A SBAS-enabled GPS receiver which decodes the data and applies the corrections
- There are a number of regional SBAS systems, two key ones are the FAA’s Wide Area Augmentation System (WAAS) and the European Geostationary Navigation Overlay Service (EGNOS). These systems are compatible, so that current WAAS-enabled GPS receivers can work in Europe

WAAS

- 38 reference stations in the continental US, Canada, Alaska, Mexico and Hawaii
- Commissioned in 2003 for aviation use. WAAS GPS is approved as a primary (sole) navigation aid for Enroute and Oceanic navigation, and CAT I Precision Approaches (LPV)

EGNOS

- Europe’s equivalent to WAAS
- The system is fully deployed and undergoing certification trials
- See the EGNOS section of the European Space Agency website <http://www.esa.int/esaNA/egnos.html>

1. RNAV and RNP theory
 - a. Introduction
 - b. The Path-Terminator
 - c. RNAV procedure design
 - d. RNP principles
 - e. RNAV and RNP applications
2. GPS Navigators and their application to RNAV
 - a. The GPS system
 - b. Databases and Coding**
 - c. Procedures
 - d. Error detection and warnings
3. P-RNAV Terminal Procedures
 - a. P-RNAV requirements and approvals
 - b. P-RNAV training topics
 - c. P-RNAV operations
4. RNAV(GPS) Approach Procedures
 - a. GPS procedure types
 - b. GPS approach requirements and approvals
 - c. GPS approach operations
5. Avionics training
6. Simulator and/or Flight training

Sources of navigation data

1. Concept of the “aeronautical data chain”

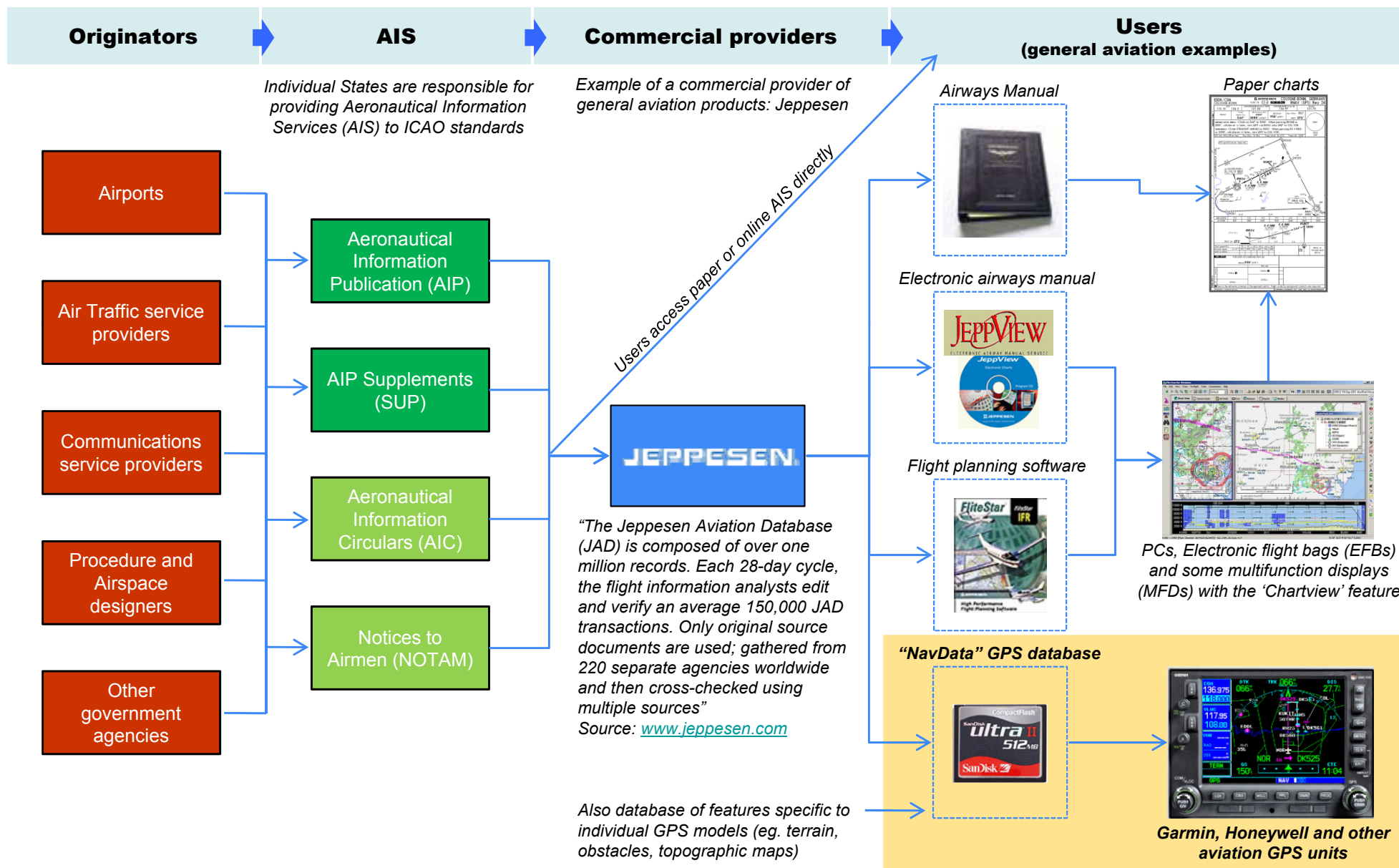

Sources of navigation data

2. An overview of standards relevant to RNAV databases

ICAO Annex 15 states that ‘Contracting States shall ensure that the integrity of aeronautical data is maintained throughout the data process from survey/origination to the next intended user’

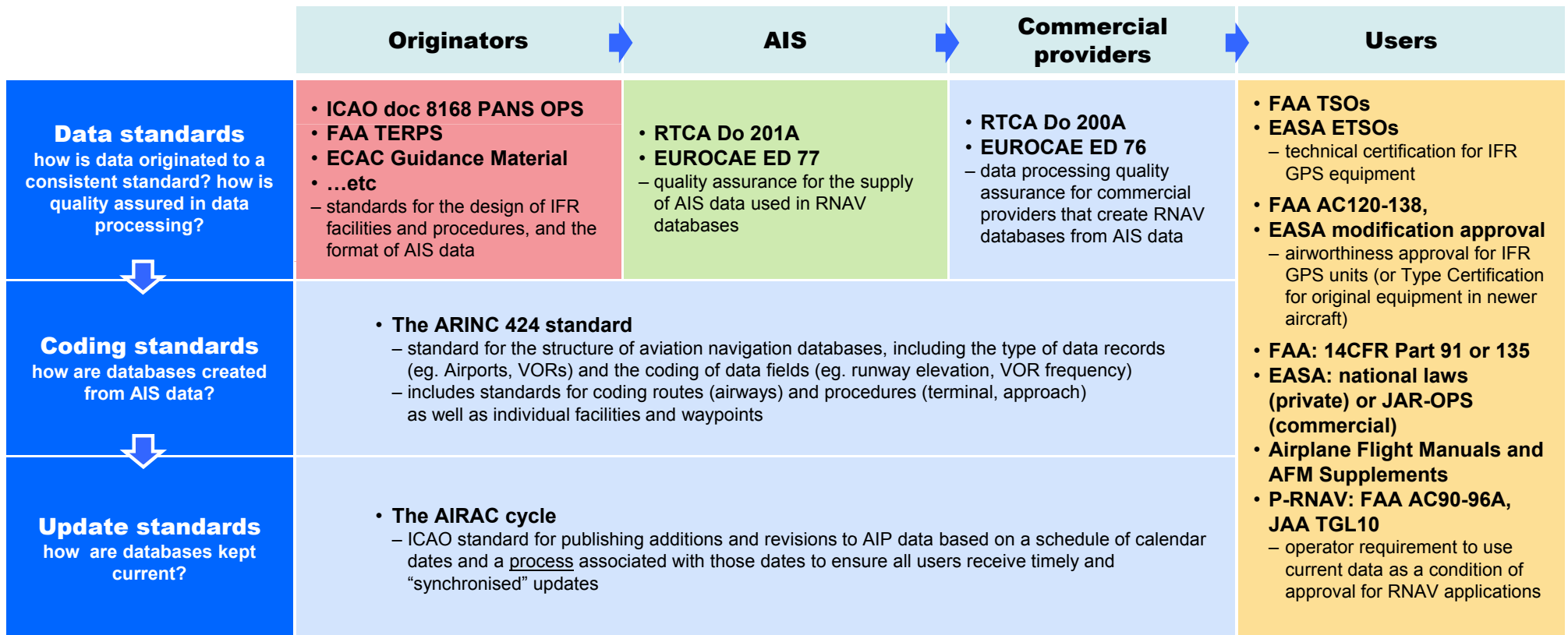

- Navigation data management and quality assurance is a specialised topic, most of which is beyond the scope of this course
- The focus in this section will be on the basics of the Do200A/ED76 standards and the AIRAC cycle, and details of ARINC 424 relevant to users of RNAV GPS equipment
- Sections 3 and 4 will cover operational approval requirements for P-RNAV and GPS Approaches

RTCA and Do200A, EUROCAE and ED76

- RTCA (Radio Technical Commission for Aeronautics) is a US non-profit organisation that develops standards for communications, navigation, surveillance, and air traffic management (CNS/ATM) with the participation of government, academic and industry stakeholders. RTCA recommendations are used by the FAA as a basis for policy and regulatory decisions



<http://www.rtca.org>

- EUROCAE (the European Organisation for Civil Aviation Equipment) is a non-profit organisation, formed in Switzerland in 1963 to provide a European forum for developing standards for electronic airborne and ground systems. Its recommendations are used by EASA for policy-making



<http://www.eurocae.eu>

- **RTCA Do200A and Eurocae ED76 are equivalent**, they were developed in the late 1990s to regulate the quality assurance of navigation databases supplied by commercial providers (such as Jeppesen, EAG, Lufthansa Systems) to airline, commercial and private users.
- **Do200A/ED76 were designed to meet the accuracy and integrity requirements of new RNAV RNP applications, such as P-RNAV**
- Airline and commercial operators are subject to quality management regulation (eg. JAR-OPS 1.035). The Do200A/ED76 standard may be used (eg. see JAA TGL 9) as a means of ensuring compliance for databases in Flight Management Systems (FMS)
- For private GA operators, the requirements for a database are specific to the airworthiness approval of an IFR installation and the limitations imposed by the Flight Manual (eg. a GPS unit may only use an approved database and data card, they have part numbers like any other aviation component)
 - for B-RNAV, a current database is not required, but paper charts must be used to verify data in an expired database
 - **for GPS approaches, a current database will be a requirement specified in the approved Flight Manual GPS section or supplement**
 - **a P-RNAV Letter of Authorisation will require use of both a current database and a supplier conforming to Do200A/ED76 (See next page and Section 3)**

References

- For the interested reader, a source of further detail on the methods of navigation data quality assurance is the Eurocontrol website, eg. the document “Integrity of Aeronautical Information - Data & Quality Management” (2003, AIM/AISD/DI/0007)
<http://www.ecacnav.com/downloads>
- The full set of original sources for data standards are (from JAA TGL 9)
 - ICAO Annex 4, International Standards and Recommended Practices : Aeronautical Charts
 - ICAO Annex 11, International Standards and Recommended Practices: Air Traffic Services
 - ICAO Annex 14, International Standards and Recommended Practices: Aerodromes and Heliports
 - ICAO Annex 15, International Standards and Recommended Practices: Aeronautical Information Services
 - ICAO Document 8126, Aeronautical Information Services Manual AN/872
 - ICAO Document 9613, Manual on Required Navigation Performance AN/937
 - EUROCAE document ED-76; Standards for Processing Aeronautical Data. RTCA Inc. document DO-200A is technically equivalent to ED-76. A reference to one document, at the same revision level, may be interpreted to mean either document
 - EUROCAE document ED-77/RTCA DO-201A, Standards for Aeronautical Information
 - EUROCAE document ED-75A/RTCA DO-236A, Minimum Aviation System Performance Standards: Required Navigation Performance for Area Navigation.

Database Supplier approvals relating to Do200A and ED76

The Type 1 and Type 2 Letters of Acceptance (LoA)



- The Do200A/ED76 standard was published in 1998
- As RNP RNAV procedures were being implemented circa 2003, many FMS and GPS systems were not available with conforming databases. It was the responsibility of AOC Operators to manually check such databases against coordinates on paper charts
- International agreements were developed to reduce the burden of manual checks and to certify Database Suppliers as conforming to Do200A/ED76 and other defined conditions. There are 2 kinds of certification:
 - the Type 1 LoA applies to databases that are not specific to any particular avionics system or aircraft, one can think of it as a “wholesaler” approval. The Type 1 LoA holder can not release databases directly to end users
 - **the Type 2 LoA applies to databases compatible with specified avionics systems and may be released directly to end-users.** The GA owner/operator is thus concerned with Type 2 LoA suppliers
- Suppliers are certified by the regulatory agency in their home country (eg. the FAA for Jeppesen, EASA for EAG, Transport Canada for CAC) and mutual acceptance of this certification has been agreed
- **For P-RNAV approval, databases sourced from the major suppliers holding Type 2 LoAs are compliant with JAA TGL10 and FAA AC90-96A.** Where a Type 2 LoA or Do200A/ED76 compliant database is not available, the Operator must continue to manually cross-check navigation data (eg. in accordance with JAA TGL10 Revision 1 para 10.6.2)
- **Honeywell, Garmin and Jeppesen hold Type 2 LoAs, but since these are equipment-specific, an operator must check that they apply to their particular model of GPS and database**
 - Garmin received a Type 2 LoA from the FAA for the G1000 and 400/500 series in April 2007
 - some modern IFR GPS units do not have a Type 2 LoA database available, but the Jeppesen data they use is Do200A/ED76 compliant, meeting the P-RNAV requirement. The operator must check the status of their individual GPS model
- Also see ECACNAV document “Database Compliant Suppliers and Integrity Checking” <http://www.ecacnav.com/content.asp?PageID=86> and Garmin website http://www8.garmin.com/aviation/type2_loa.jsp

What is the AIRAC cycle?

Introduction to AIRAC

- From the Aeronautical Information Management section of the Eurocontrol website: <http://www.eurocontrol.int/aim>

Aviation data is constantly changing; airspace structures and routes are revised, navigation aids change, SIDs and STARs are amended, runway and taxiway information changes. It is essential, for both efficiency and safety, that Pilots, Air Traffic Controllers, Air Traffic Flow Managers, Flight Management Systems and Aviation Charts all have the same data set. How can this be achieved? The answer is AIRAC

AIRAC stands for Aeronautical Information Regulation And Control and stems from the ICAO Annex 15 - Aeronautical Information Services (AIS) document. AIRAC defines a series of common dates and an associated standard aeronautical information publication procedure for States

All information provided under the AIRAC system is published in paper form and distributed by national AIS units at least 42 days in advance of the effective date, with the objective of reaching recipients at least 28 days in advance of the effective date

- A commercial supplier like Jeppesen thus receives AIS updates at least 28 days before the Effective Date of a new cycle and uses that time to code the changes into its electronic and paper products, and to distribute updates to customers
- AIRAC thus provides a standardised batch updating process organised around 13 cycles of data per year, each becoming valid on an Effective Date and remaining valid for ~28 days until the next Effective Date.
- States may publish charts on a different cycle from AIRAC, eg. 7 or 14 days for terminal charts, 28 or 56 days for enroute charts
- Jeppesen break down the distribution of paper and electronic charts into 2 batches per AIRAC cycle, delivered at 14 day intervals. GPS databases, however, are updated 13 times per year in accordance with the AIRAC cycle
- Because the input to an AIRAC cycle is “frozen” up to 42 days before it becomes effective, more urgent changes are promulgated by NOTAM

AIRAC Cycle: Jeppesen example

- AIRAC cycle Effective Dates are available from AIPs or the Eurocontrol website, for several years in advance, and from the preface of the Jeppesen Airway Manual
- Example: imagine today is 14 January 2008, the next AIRAC Effective Date is 17 January 2008:

Next AIRAC Effective Date

today

M	T	W	T	F	S	S
	1	2	3	4	5	6
7	8	9	10	11	12	13
14	15	16	17	18	19	20
21	22	23	24	25	26	27
28	29	30	31			

Jeppesen “Issue Date” for their “01-2008” cycle for Airway Manuals and JeppView – changes become Effective on 25 Jan

Jeppesen “Issue Date” for the “02-2008” cycle; changes Effective on 14 Feb

Note: these Jeppesen products have 26 Issue cycles per year but they become effective only on the 13 AIRAC effective dates

- The customer should have received paper chart and JeppView disc updates by today
- NavData GPS updates should be available online from “JSUM”, the update management software, about 1 week prior to the 17 Jan Effective Date
- If the prior database was loaded in December, and the new database has now been loaded, the illustration below is an example of how a GPS Database Validity page should read:

Database now “loaded” for use in navigation is current and will expire on 16 January 2008

Next cycle database has been stored, and will become current on 17 January 2008, when the GPS unit will automatically load it

DB Effective Dates

*Database A:
Starts: 12/20/2007
Ends: 1/16/2008

Database B:
Starts: 1/17/2008
Ends: 2/13/2008

* - Database Loaded

Summary: three tasks a GA pilot must perform before using an approved RNAV database



Coverage

- Ensure that the GPS database and other charts required have the coverage needed for the intended flight - geographic region, specific airports and types of procedure



- Coverage is not always self-evident for a user subscribing to European Region data; the countries included in a given subscription vary by product
- If you have GPS database coverage for a particular country, it may not be included in the paper chart coverage (or PC readable electronic version), and vice-versa
- Note: GPS databases usually do not include Category A and B approaches



Currency

- Ensure that the GPS database and other charts required are valid for the current Effective Period of the AIRAC cycle
- Check NOTAMs and database supplier alerts



- Currency is particularly important at present, because of the rate at which new procedures are being introduced as many European countries begin to implement P-RNAV and GPS approaches
- It is not legal or practical to try and enter these as user waypoints. An approved, current database is essential
- Note that paper charts and software products may be distributed up to 2 weeks before they become effective



Cross-Check

- Cross-check the GPS database routes and procedures that will be used against published charts



- The quality of approved navigation data is very high and gross errors are relatively rare
- However, as new procedures are introduced, discrepancies arise quite regularly between AIP charts, commercial service provider charts and GPS databases
- In addition, RNAV databases are an inherently different format from paper charts and some waypoints will not be identical in both (see ARINC 424 pages later in this section)
- Flying an RNAV procedure is not the right time to be puzzling over such discrepancies



- **The requirements for approved database coverage, currency and cross-checks are not regulatory “gold plating”; they are a practical, as well as legal, necessity for RNAV operations**

If my GPS database is approved and current, do I really need to cross-check it with published charts?

Example: Jeppesen NavData alerts for Europe in the 4 weeks to 22 December 2007

December 22, 2007
 Germany, Multiple Locations
 Step Down Fixes, Cycles 0713 and 0801
Step-Down Fixes on German RNAV (GPS) Approach Procedures

December 13, 2007
 Erfurt, Germany, Erfurt (EDDE)
 RNAV (GPS) RWY 10 [R10], Cycle 0713
INCORRECT ALTITUDE ON 'ERF' APPROACH TRANSITION

December 10, 2007
 Cagliari, Italy, Cagliari Elmas (LIEE)
 RWY14/32, I32, D14, D32, N32, Cycle 0713
INCORRECT RUNWAY AND APPROACH PROCEDURE INFORMATON

November 25, 2007
 Cologne-Bonn, Germany, Cologne-Bonn Airport (EDDK)
 GULKO 14 [GUL14], KOPAG 14 [KOP14], and NORVENICH 14 [NOR14] Rwy 14L/R RNAV Transitions, Cycle 0712
INCORRECT COORDINATES FOR SUPPLEMENTAL RNAV WAYPOINTS



Over 4 weeks, 4 problems in the European GPS database significant enough to warrant coding changes and a user alert.





NavData® Alert

!! URGENT !!

Date: 21 December 2007

Subject: Germany
 Multiple Locations
 Step Down Fixes
 Cycles 0713 and 0801

Step-Down Fixes on German RNAV (GPS) Approach Procedures

Jeppesen received source information for RNAV (GPS) approaches from the German DFS (Deutsche Flugsicherung) that we interpreted as requiring step down fixes between the FAF and MAP. DFS recently informed us that these step down fixes should not be included in Jeppesen NavData and requested that we remove them (reference NOTAM A3539/07). For NavData cycle 0713, effective 20 December, RNAV (GPS) approach procedures for airports in Germany (FIRs EDWW, EDGG and EDMM) are unusable for operators with avionics equipment that processes final approach stepdown fixes.

Please note that step down segments do not appear in all avionics systems that use Jeppesen NavData. Step down segments are filtered out by Jeppesen as requested by the avionics manufacturer when their equipment cannot properly handle step down data. If you have any questions concerning this, please contact Jeppesen at 303-328-4445 or the email address or fax number below.

The affected step down segments and waypoints will be deleted from the approach coding for the procedures listed below in NavData cycle 0801, effective 17 Jan 2008:

The affected step down segments and waypoints will be deleted from the approach coding for the procedures listed below in NavData cycle 0801, effective 17 Jan 2008:

Airport (Identifier)	City Name	Procedure Name [Identifier]
Brandensteinsebene (EDQC)	Coburg, Germany	RNAV (GPS) Rwy 30 [R30]
Hannover (EDDV)	Hannover, Germany	RNAV(GPS) Rwy 09L [R09L]
Hannover (EDDV)	Hannover, Germany	RNAV(GPS) Rwy 09R [R09R]
Hannover (EDDV)	Hannover, Germany	RNAV(GPS) Rwy 27L [R27L]
Hannover (EDDV)	Hannover, Germany	RNAV(GPS) Rwy 27R [R27R]
Magdeburg (EDBM)	Magdeburg, Germany	RNAV(GPS) Rwy 27 [R27]
Straubing (EDMS)	Straubing, Germany	RNAV(GPS) Rwy 28 [R28]

YES

If my GPS database is approved and current, do I really need to check NOTAMs for navigation facilities and procedures?

Example: EGBJ Gloucestershire

EGBJ: RNAV (GNSS) approach plate current in AIRAC cycle to 14 Feb 08

GPS Approach published, current and included in databases

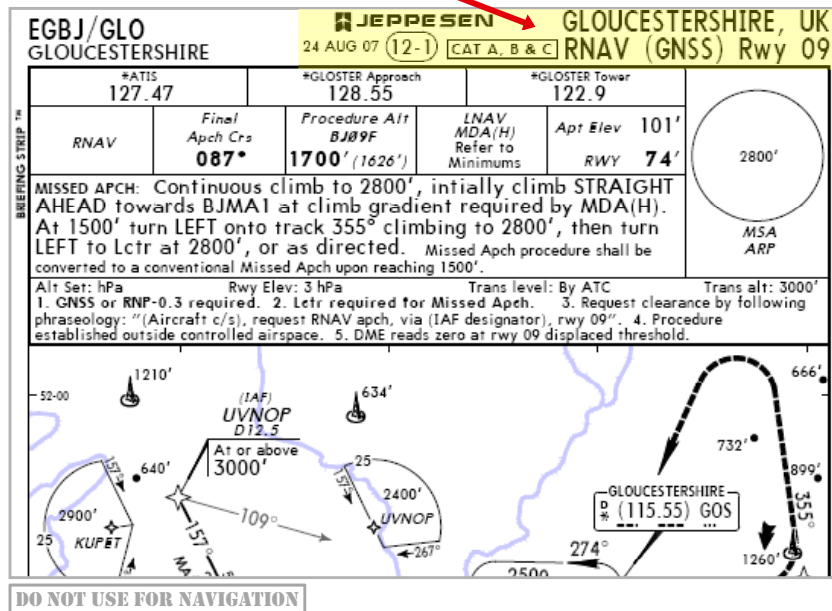

EGBJ: Airfield NOTAMs 3 Feb 08

...but GPS Approaches NOTAMed not available

EGBJ GLOUCESTERSHIRE GLO

REF: L0004/08
From: 2008-Jan-01 Tue 10:57 To: 2008-May-31 Sat 10:00
ICAO: EGBJ GLOUCESTERSHIRE
RNAV (GNSS) APPROACHES NOT AVBL

REF: L0019/08
From: 2008-Jan-02 Wed 08:00 To: 2008-Mar-31 Mon 23:59
ICAO: EGBJ GLOUCESTERSHIRE
ROTORS RUNNING REFUELS NOT AVAILABLE DURING FOLLOWING PERIODS: MON-THURS 0830-0900 1815-1900 FRI 0830-0900 1530-1600 1815-1900 SAT 1100-1130 SUN 1400-1430 1700-1730

REF: L0387/08
From: 2008-Feb-01 Fri 13:32 To: 2008-Feb-29 Fri 09:00
ICAO: EGBJ GLOUCESTERSHIRE
OBST LGT BRG 075 DEG MAG 804M FM ARP U/S

➔ YES

If am using reputable aviation products, does it matter if the data is not approved for IFR navigation?

Example: non-approved terrain data in popular IFR flight planning software

Comparison of Raster Chart with vertical profile depiction

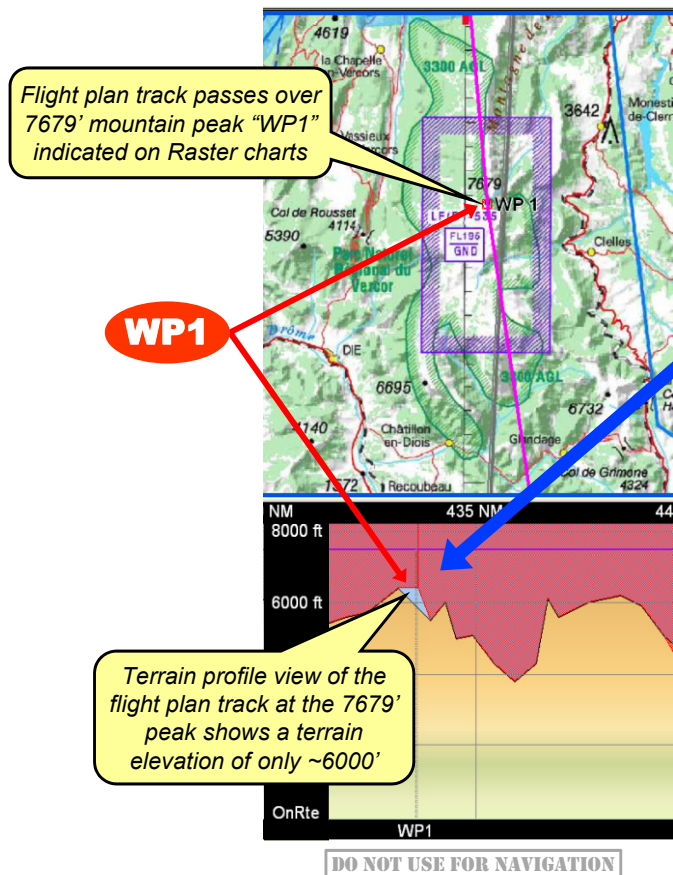

Comparison of Vector chart with Raster chart position data and vertical profile data

At this sample point, in the French Alps:

Terrain profile view understates actual terrain by ~1500'

Map shift between Vector and Raster chart of ~1nm

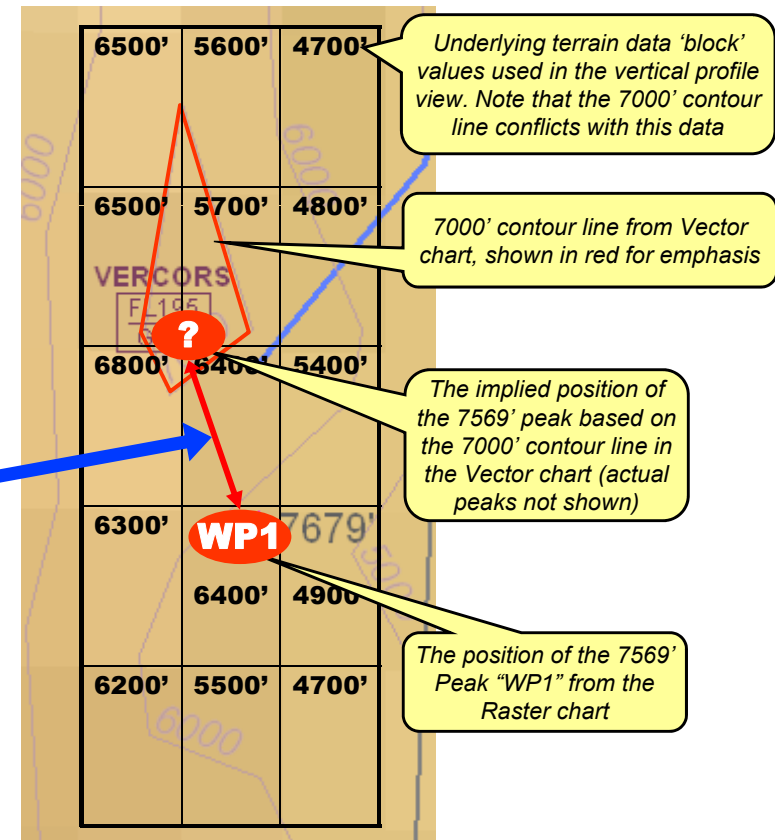

➔ YES

- **ARINC** was founded in 1929 as “Aeronautical Radio Inc”, owned by the four major US airlines of the time and taking on responsibility for all ground-based, aeronautical radio stations. Since the 1930s, the company has developed various standards for aircraft electronics
 - eg. for the trays and boxes used in panel-mount radios, and the ARINC 429 standard for interfaces between different kinds of avionics
 - The first RNAV systems, in the late 1960s, did not store any navigation data; they were basic VOR/DME “shifters”
 - In the early 1970s, avionics manufacturers began to introduce Flight Management Systems (FMS) with a stored database of navigation facilities, each using a proprietary standard
 - An industry committee was formed to standardise how FMS navigation data was formatted and coded, and this led to the adoption of ARINC Specification 424 in 1975
 - The early versions only accommodated individual navaids and waypoints. ARINC 424-3, published in 1982, introduced the ‘path-terminator’ concept (*see Section 1b of this manual*) and allowed procedures and approaches to be coded
 - ARINC 424 is updated as new navigation technology and RNAV applications emerge, the current version (as of March 2008) is 424-18
-
- ➡ • **The rest of this section will cover two ARINC 424 topics relevant to GA pilots**
 - the structure of navigation databases and records
 - the conventions used for coding and naming database waypoints
 - **Section 2c will cover the coding of ‘traditional’ and RNAV procedures**

ARINC 424: database structure

- The database consists of ~30 different types of “Record”, each with 132 characters of data organised into a particular structure of “Fields” (several characters representing an item of information, eg. a frequency)

Record Types
132 characters per Record, organised into different Fields for each Record type

VHF Navaid

Waypoint

Holding

Airport

Gate

SID, STAR, Approach

Runway

NDB Nav aids

Localiser and Glide Slope

Company Route

Localiser Marker

Path Points

Airport Communications

MSA

Airways Marker

Cruising Tables

FIR/UIR

GRID MORA

Enroute Airways

Enroute Airways Restrictive

Enroute Communications

Preferred Routes

Controlled Airspace

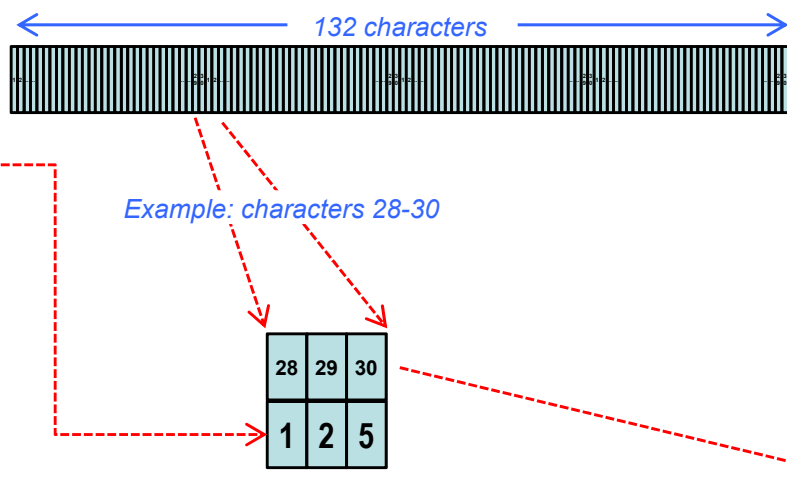

Example: characters 28-30

Example, characters 28-30 of the Airport Record are defined as the “Longest Runway” Field, the data content in this illustration “125” means the longest runway is 12,500 feet

Example: definition of Fields in an Airport Record

Column	Field Name (Length)	Ref
1	Record Type (1)	5.2
2 thru 4	Customer/ Area Code (3)	5.3
5	Section Code (1)	5.4
6	Blank (spacing) (1)	
7 thru 10	Airport ICAO Identifier (4)	5.6
11 thru 12	ICAO Code (2)	5.14
13	Subsection Code (1)	5.5
14 thru 16	ATA/IATA Designator (3)	5.107
17 thru 18	Reserved (Expansion) (2)	
19 thru 21	Blank (spacing) (3)	
22	Continuation Record Number (1)	5.16
23 thru 27	Speed Limit Altitude (5)	5.73
28 thru 30	Longest Runway (3)	5.54
31	IFR Capability (1)	5.108
32	Longest Runway Surface Code (1)	5.249
33 thru 41	Airport Reference Pt. Latitude (9)	5.36
42 thru 51	Airport Reference Pt. Longitude (10)	5.37
52 thru 56	Magnetic Variation (5)	5.39
57 thru 61	Airport Elevation (5)	5.55
62 thru 64	Speed Limit (3)	5.72
65 thru 68	Recommended Navaid (4)	5.23
69 thru 70	ICAO Code (2)	5.14
71 thru 75	Transitions Altitude (5)	5.53
76 thru 80	Transition Level (5)	5.53
81	Public/Military Indicator (1)	5.177
82 thru 84	Time Zone (3)	5.178
85	Daylight Indicator (1)	5.179
86	Magnetic/True Indicator (1)	5.165
87 thru 89	Datum Code (3)	5.197
90 thru 93	Reserved (Expansion) (4)	
94 thru 123	Airport Name (30)	5.71
124 thru 128	File Record Number (5)	5.31
129 thru 132	Cycle Date (4)	5.32

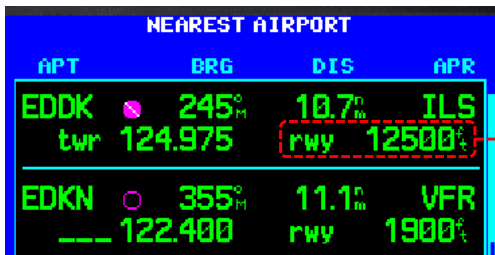

Example: Airport data from Garmin 530 “NRST” page

There are four kinds of ARINC 424 Record

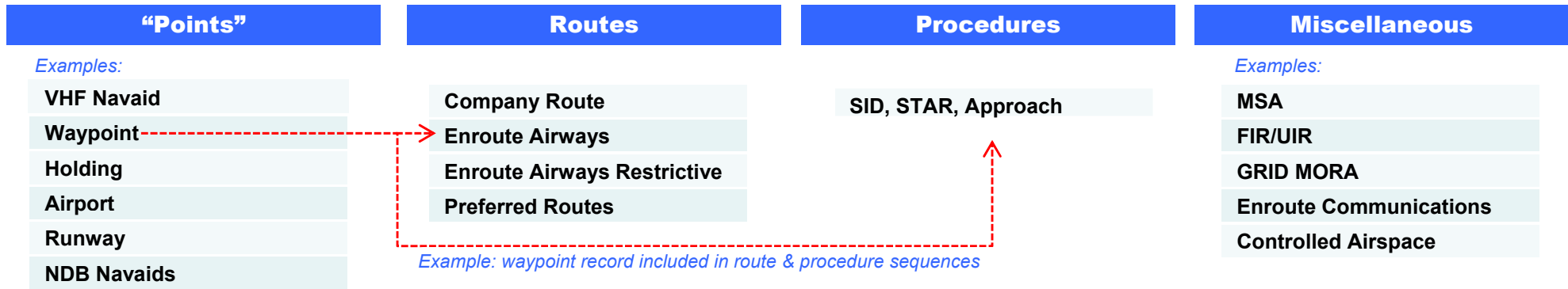

- Records of specific locations such as radio nav aids, traditional fixes and intersections, RNAV waypoints and airports
- Some fields are common to all these types of record (eg. latitude & longitude, ICAO identifier), others are specific to the type of point



- **Most types of records are “independent” of each other, except for airports, which have a basic record plus several associated records for individual runways, gates, ILS facilities etc.**

- Simple routes which are a named sequence of fixed points
- Route data (eg. for an Airway) includes
 - fix sequence number
 - fix identifier
 - route type
 - RNP applicable
 - max/min altitudes
 - “Rho”: distance in nm to next fix
 - “Theta”: magnetic bearing to next fix



- **A fix or waypoint will have both its own “stand-alone” record, and its record repeated within any Route and Procedure sequences it is part of**
- **A waypoint may be designated as “Fly-Over” in one route and “Fly-By” in another**

- Complex routes coded as a named sequence of Path-Terminators (see Section 1b)
- May include Speed and Altitude limits associated with each fix



IMPORTANT NOTE

- **Most GPS maps only depict Class B, C and D airspace. For example, Class A is omitted because in the USA it is the entire airspace above FL180. However, this means that low-level Class A (and Class E & F) airspace in Europe is not displayed and airspace alerts are not provided**

Note: these four kinds of Record are not a formal ARINC distinction, only used here for descriptive purposes

GPS units vary in terms of which ARINC data they support

Garmin examples:

Garmin 430, 530 and piston aircraft G1000



Garmin 480



Garmin G1000 in turbine aircraft

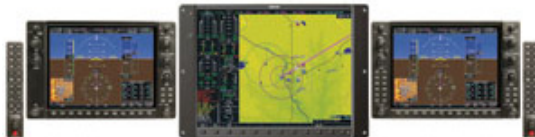

"Points"	Routes	Procedures
Fully supported	Not supported	LNAV supported VNAV and Speed not supported
Fully supported	Fully supported	LNAV supported VNAV and Speed not supported
Full, modern Flight Management System (FMS) implementation of LNAV, VNAV and Speed in all IFR routes and procedures		

• WAAS GPS units do provide a 'synthetic' glideslope during the final approach phase of an LPV procedure, but not VNAV throughout a procedure. The Garmin "Advisory VNAV" feature relies on manual entry of target levels along a flight plan – it does not support database coded target and limiting altitudes within a procedure

- ➔ Variations in how data is treated also occur between identical GPS models with different software versions
- The only definitive guide is the GPS manual that is part of the aircraft Flight Manual in an IFR approved installation

Coordinate fields in ARINC 424

- The ARINC 424 latitude and longitude fields use the following convention:
 - Latitude is stored as nine alphanumeric characters in the form “N” or “S” plus degrees, minutes, seconds, and hundredths of seconds, eg. N50575196
 - Longitude is stored as ten alphanumeric characters in the form “W” or “E” plus degrees, minutes, seconds, and hundredths of seconds, eg. E007270361
- There are 60 seconds in a minute of arc
- Paper charts in the AIP or from commercial suppliers usually use degrees, minutes and **decimal tenths of a minute of arc**, not tens of seconds of arc
- GPS units typically convert the ARINC format and display degrees, minutes and **decimal hundredths of a minute of arc**, not seconds of arc

Paper chart and database examples

Example: from Jeppesen paper chart

DK555
N50°57.5'
E007°27.0'

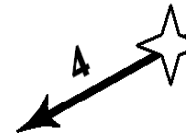

• 57.5 minutes of arc

Decimal point indicates the last 5 is 0.5 minutes of arc, not 50 seconds

Example: from Garmin 530 database

INT DK555 ▲
REGION
GERMANY
POSITION
N 50°57.51'
E007°27.03'

• 57.51 minutes of arc

• not 57 minutes of arc and 51 seconds

Note the decimal point, and the single apostrophe minute symbol after the group of 4 digits, both indicating minutes and a decimal fraction of minutes

- ➔ • This illustrates one of the many reasons manually-entered waypoints may not be used for P-RNAV or RNAV Approaches, and only with caution in other aviation applications
 - confusing seconds of arc with decimal fractions of a minute of arc is easily done and can result in errors of up to 1/3 of a nautical mile

Coding of magnetic variation

- RNAV equipment displays directional guidance in terms of magnetic tracks and bearings
- Thus, ARINC 424 records always include the magnetic variation associated with fixed points
- There are three types of magnetic variation field
 - measured **Magnetic Variation**, used for physical location records, such as Airports
 - **Station Declination**, used for VORs, which is the tested difference between true north and the 360 radial of the VOR
 - **Dynamic Magnetic Variation**, used for RNAV waypoints, which is derived from a computer model rather than actual measurement
- Bearings along an Airway, and the headings and tracks in Path Terminators, are all coded with reference to magnetic north

GPS calculation and display of magnetic tracks

- There are various magnetic north references available
 - local (at a given point) or regional
 - measured at a given time, or values valid for a period of time such as 1 year or 5 years
- Although ARINC databases do include the magnetic track or VOR radial along routes and procedures, these will typically not be used by GPS navigation processors
- Instead, the GPS will calculate magnetic track based on the latitude and longitude of waypoints and the magnetic variation along the route segment. This calculated track (DTK) may 'jump' by 1 degree along relatively short route segments, as a result of rounding and changes in magnetic variation
- The magnetic variation may be sourced from the fields associated with waypoints in the database, or from the GPS unit's internal magnetic variation model

- ➔ • **Small differences of ~1 degree are common between charted magnetic tracks and GPS-calculated magnetic tracks**
- **If the waypoint cross-check of a GPS flight plan reveals no discrepancies, such small differences may be ignored and the GPS-derived magnetic track used**

ARINC 424 name and coding conventions

1. Introduction to names and identifiers

- ICAO Annex 11 defines the international standard for the designators of nav aids, waypoints, airways and procedures
- Where a waypoint is marked but not named in AIP charts, ARINC 424 provides standards for creating names
- Where a procedure does not include all the waypoints needed for RNAV guidance, the state can define additional “Computer Navigation Fixes” (CNF) or the database supplier will create CNFs and assign them database identifiers

Names	ICAO Identifiers	Database Identifiers
The full “prose” version of the name of a facility, waypoint or procedure	A short letter or alphanumeric version of a name, corresponding to the ICAO Annex 11 standard. Published on paper charts, and transmitted as a Morse ident by radio facilities	The record name in an RNAV database. Generally the same as the ICAO identifier, but ARINC 424 may require some variation. CNFs may only have a database identifier and no published chart designator

Examples

London Heathrow	EGLL	E G L L
Daventry	DTY	D T Y
waypoint name is the same as identifier ←	KENET	K E N E T
Lambourne Three Alpha	LAM 3A	L A M 3 A
a CNF created by the database supplier and not published in paper charts ←		C I 2 7

- Identifiers are not always unique, waypoint and procedure naming conventions change and RNAV databases are an inherently different format that can not perfectly “mirror” paper charts

➡ **An understanding of naming conventions and coding is essential for RNAV operations**

Why is an understanding of naming conventions and coding essential for RNAV operations?

Example of an accident resulting in 160 fatalities



N651AA

Controlled flight into terrain accident near Cali, Colombia, December 20th 1995
American Airlines Flight 965, Boeing 757-223, N651AA

Names	ICAO Identifiers	Database Identifiers
Rozo NDB	R	ROZO
Romeo NDB	R	R

both in Colombia

ARINC 424 does not permit duplicate identifiers within the same country, hence full name used for Rozo

Comment relating to non-unique identifiers: two NDBs in Colombia with different names but the same identifier "R"

Extracts from the Accident Report of Colombia's Aeronautica Civil (with emphasis added)

*"The investigation determined that because of rules governing the structure of the FMS database, **Rozo**, despite its prominent display as "R" on the approach chart, was not available for selection as "R" from the FMS, but only by its full name. The evidence indicates that this information was not known by the flight crew of AA965."*

Comments that the crew did not cross-check the RNAV waypoint with published chart coordinates

"Although the differences between the presentation of the same information could be confusing, and the selection of Romeo instead of Rozo can be understood according to the logic of the FMS, the fact remains that one of the pilots of AA965 executed a direct heading to Romeo in violation of AA's policy of requiring flight crew members of FMS-equipped aircraft to verify coordinates and to obtain approval of the other pilot before executing a change of course through the FMS"

Comments relating to differences in ARINC 424 names from those in paper charts. Similar issues apply when CNFs are used that do not appear on paper charts

*"Furthermore, considerable additional differences existed in the presentation of identical navigation information between that on the approach charts and that in the FMS data base, despite the fact that the same company supplied the data to both. For example, **DME fixes for the Cali VOR DME runway 19 approach that were labelled on the charts as D-21 and D-16 were depicted on the FMS using a different nomenclature entirely, that is, CF19 and FF19. The company explained that it presented data in the FMS according to a naming convention, ARINC 424, developed for electronic data, while data presented on approach charts met requirements of government civil aviation authorities"***

- ➔ **The single-pilot GA IFR operator can face RNAV challenges that have defeated experienced professional crews from the best airlines**
- 14 years after the Cali accident, these issues are still very relevant to RNAV database users**

ARINC 424 name and coding conventions

2. Overview of databases identifiers

“Points”	Routes and Procedures	Procedure Waypoints
Airports [a][a][a][a] <ul style="list-style-type: none"> • 4 letter ICAO identifier eg. EGLL • ‘K’ added to US 3 letter codes, eg. KLAX 	Airways [a][n] [a][a][n][n][n] <ul style="list-style-type: none"> • Alphanumeric identifiers of 2-5 characters. But, not supported in most panel-mount GPS units 	Terminal waypoint names [a][a][a][a][a] <p>“Strategic” waypoints:</p> <ul style="list-style-type: none"> • Terminal waypoints of major significance to ATC, often designating the start and end of routes and major transitions • Use the 5LNC or the 3 letter identifier of a navaid <p>“Tactical” waypoints: [a][a][x][n][n]</p> <ul style="list-style-type: none"> • Terminal waypoints solely for use in the specific terminal area and not designated as strategic • ‘Tactical’ RNAV terminal waypoints use a 5 character alphanumeric. The first two letters (‘aa’) are the last two letters of the airport ICAO code, the ‘x’ is either a letter code (eg. orientation N,E,S or W) or a digit, and the last 2 characters (‘nn’) are digits from 00 to 99 • In older procedures, where a tactical waypoint does not have a suitable name, a CNF identifier will be created using a 5 character alphanumeric, in the form “Dnnna”, based on the “bearing/distance” convention (see later pages) <p>Approach waypoint names <i>various – see next pages</i></p> <ul style="list-style-type: none"> • May be named and published (eg. a navaid or 5LNC) • May be published but with only a generic name (eg. the Outer Marker, or a Final Approach Fix) or no name, in which case a CNF identifier will be created (see later pages) using the Airport CNF convention
VORs and VOR-DMEs [a][a][a] <ul style="list-style-type: none"> • Usually a 3 letter identifier eg. ABC • Sometimes a 2 letter identifier, but no longer used for VORs in Europe 	Terminal procedure names [a][a][a][n][a] <ul style="list-style-type: none"> • ARINC 424 permits alphanumeric identifiers of up to 6 characters (see section 2c) • The leading letters usually refer to a fix at the start or end of a procedure. In the case of a 3 letter VOR identifier, the “aaana” format is used. If the fix is a 5LNC, the last letter of the 5LNC is dropped and the procedure name format is “aaaana” 	
NDBs [a],[a][a],[a][a][a] <ul style="list-style-type: none"> • 1, 2 or 3 letter identifier eg. A, AB, ABC 	Approach procedure names [a][a][a][n][n] <ul style="list-style-type: none"> • Alphanumeric identifiers of 3-6 characters are used <ul style="list-style-type: none"> - 3 characters might specify an approach not specific to a runway, eg. simply ‘NDB’ - 5-6 characters are typical, eg. ‘ILS27’ or ‘ILS27R’ • They may be specified as starting from an approach transition waypoint or starting with vectors to intercept the final approach track 	
En-route waypoints [a][a][a][a][a] <ul style="list-style-type: none"> • 5 character alphanumeric names; usually either 5 letters (the ICAO “5 letter name-code” or 5LNC) or 3 letters and 2 numbers representing a VOR reference and a DME distance in the form aaann 		
Other “point” records in databases <ul style="list-style-type: none"> • Although encoded in ARINC 424 databases, other facilities (eg. ILSs, runways) are usually not directly accessible by the GPS user except as part of Airport or Procedure records 		



- **Published identifiers and database identifiers are generally identical**
- **Note that some identifiers are not unique, except within a country or geographic region (within Europe, mainly applies to NDBs)**



- **Terminal procedure database identifiers are published in [square brackets] on paper charts**
- **Approach procedure identifiers are usually the same as the charted procedure names, but see Section 2c for potential ambiguities**



- **Procedure waypoint names are only unique within a terminal area or for a particular airport**
- **Note the similar format used for RNAV Tactical waypoint identifiers and the Bearing/Distance convention for CNFs**

ARINC 424 name and coding conventions

3. Since identifiers are not always unique, how is a specific record located?

	Airports	Radio Aids	Enroute Waypoints	Terminal Procedures	Approach Procedures
Is the Identifier unique?	<ul style="list-style-type: none"> ICAO 4 letter airport codes are unique worldwide 	<ul style="list-style-type: none"> NDB and VOR identifiers are not unique 	<ul style="list-style-type: none"> 5LNCs are unique ..but not all enroute intersections use 5LNC identifiers 	<ul style="list-style-type: none"> Procedures and procedure waypoints are unique to a particular TMA 	<ul style="list-style-type: none"> Approaches and final/missed approach waypoints are unique to a particular airport
How is the right record selected if duplicates exist?	<ul style="list-style-type: none"> (n/a: no duplicates) 	<ul style="list-style-type: none"> Be familiar with how and when the GPS identifies that duplicate records exist for an identifier Select the record with the correct <u>name</u> and <u>geographic region</u> 		<ul style="list-style-type: none"> Confirm correct airport Select runway, transition and procedure identifier 	<ul style="list-style-type: none"> Confirm correct airport Select runway, transition and approach type
How is a record identification confirmed?	<ul style="list-style-type: none"> Check the airport name in the database to confirm ICAO code 	<ul style="list-style-type: none"> Gross error check of RNAV waypoint position with paper chart and radio instruments 		<ul style="list-style-type: none"> Check procedure waypoints with paper chart <i>terminal and approach waypoints should only be selected from within a loaded procedure</i> Check the end waypoint of the STAR matches the transition at the start of the approach 	

Garmin 530 examples

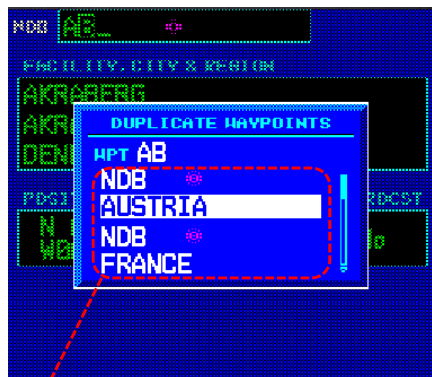

Example: select geographic region from GNS530 list of duplicated records available for a given identifier selection

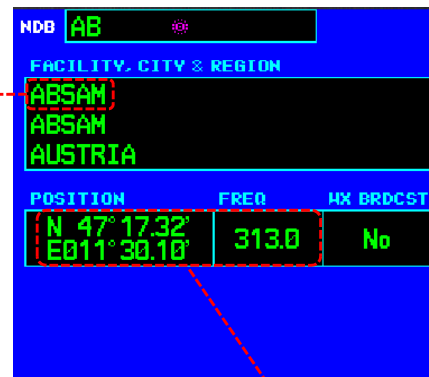

Confirm facility name correct

data for gross error check and radio cross-check

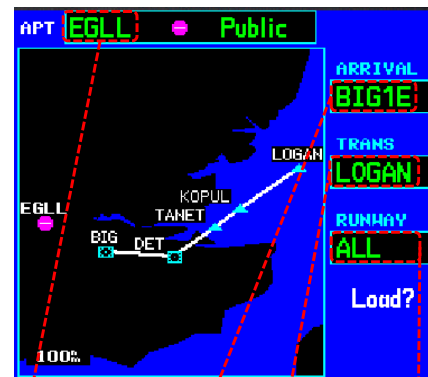

1. Confirm airport correct

2. Select procedure identifier

3. Select transition
4. If applicable, select runway

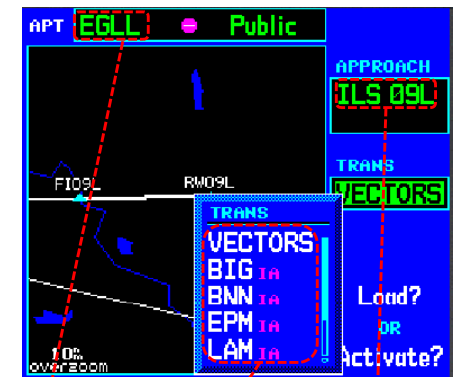

1. Confirm airport correct

2. Select procedure identifier – check list for multiple similar procedures
3. Select transition

ARINC 424 name and coding conventions

4. When are database waypoints different from those on paper charts?

1. When paper chart names are not suitable for ARINC 424	2. When waypoints are not named on paper charts, or where only a generic “label” is used	3. When a waypoint does not exist on paper charts, but is required for coding a procedure
<ul style="list-style-type: none">• ARINC 424 limits waypoint database identifiers to 5 character, and duplicate identifiers are not permitted within a single country• Whilst RNAV and the use of FMS databases were relatively new, paper charts in the USA and Europe would often have fix and intersection names not compatible with ARINC 424• However, in Europe, AIP charts have been updated so that ARINC-compatible names are used in all enroute navigation	<ul style="list-style-type: none">• Examples:<ul style="list-style-type: none">- unnamed fixes or intersections- unnamed turning points in procedures (eg. simply defined by a time, lead radial)- points on procedures labelled only with a DME distance (eg. D4.5), which is not sufficiently unique to be used as a database identifier- points with generic labels such as FAF, IAF, OM; which, again, are not unique enough – a single airport may have numerous such points• Note that a “generic” name (eg. D4.5) may be used as a database identifier if it is unique within the procedures at a particular airport	<ul style="list-style-type: none">• Procedures where the paper chart description is adequate but too “ambiguous” for the more deterministic coding needed in RNAV databases. Examples:<ul style="list-style-type: none">- the localiser intercept after a base turn will often not have a published waypoint, but RNAV systems may require one to establish the track segment from the intercept to the FAF- the point at which a DME arc is intercepted will often not have a paper chart waypoint defined, but one may be needed for the path-terminator coding in a database



- ARINC 424 has coding rules for creating waypoint names when suitable names are lacking, and for creating Computer Navigation Fixes (CNFs) when suitable waypoints are lacking
- These coding rules can be summarised as 3 waypoint conventions:
 - **Enroute waypoint naming convention**
 - **Procedure CNF Bearing/Distance convention**
 - **Airport CNF convention**



• Each of these conventions is described in the next pages

ARINC 424 name and coding conventions

5. Enroute waypoint naming

If an enroute fix has a published name which is not suitable for ARINC 424

- The method applied in ARINC 424 coding is as follows
 - If the name is greater than 5 letters, various rules are applied to shorten it to a "5LNC"
 - eg. 'COTTON' becomes **COTON**
 - eg. 'CLEAR LAKE' becomes **CLAKE**
 - If the 5LNC rule results in duplicate identifiers, a 4 letter name with a suffix number is used, eg. **CLAK1** **CLAK2**
 - Where more than one short identifier is published, ARINC 424 uses a long name for one of the duplicates eg. **R** and **ROM**

If an enroute fix or intersection is published without a name

- The identifier is constructed from the identifier of, typically, the nearest airway VOR (which is the reference for the waypoint) and the distance from that VOR
 - If the distance is less than 100nm, the identifier format is the three letters of the VOR ident followed by a two digit distance, eg a waypoint 35nm from "ABC" VOR: **ABC35**
 - If the distance is 100-199nm, the identifier format is the three letters of the VOR ident preceded by the last two digits of the distance eg a waypoint 135nm from "ABC" VOR: **35ABC**
- If unnamed waypoint is collocated with a named waypoint on a different route structure then the named waypoint's identifier is used

- European enroute charts have been updated with airway waypoint identifiers that are always compatible with ARINC 424, hence the paper charts and databases should be highly consistent
- The three formats used are navaid identifiers, 5LNCs and the 'reference VOR plus 2 digit distance'

Example of Airway waypoints

Jeppesen E(LO)2 low altitude enroute chart (paper)

Note square brackets and cross symbol indicating a CNE database identifier which has no flight plan filing or ATC function, only aids pilot orientation.

Jeppesen low altitude enroute chart (PC version in JeppView)

Garmin GNS480 airway route

Library	DIST	Modify
EGPF		
BRG 126°	43.0	
TLA	43.0n	
N601 → BAKER:		
BRG 162°	7.9	
TLA08	50.9n	
BRG 162°	5.1	
ESKDO	56.1n	
BRG 162°	11.1	
TLA24	67.2n	

↑↓ FPL
SAVE EXEC XPND

DO NOT USE FOR NAVIGATION

Reference: extract from Jeppesen Enroute Chart legend

Source: Jeppesen Airway Manual Introduction section

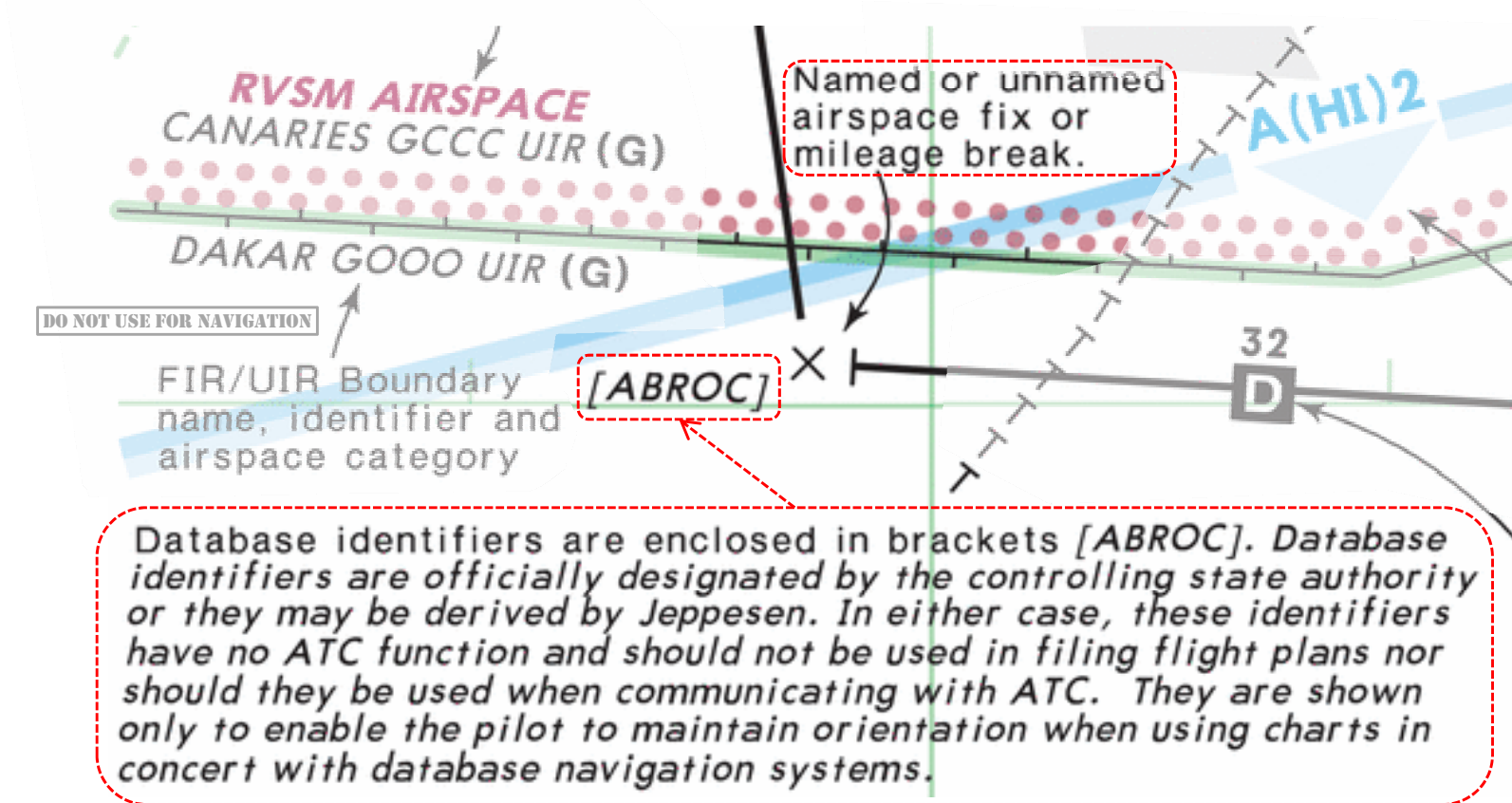

- Note: the nomenclature of waypoint names is sometimes confusing.
- “Database identifier” can be a generic term for the ARINC 424 short, coded name of any navaid, fix, airport etc.
- In the context of the chart legend above, “database identifier” means a Computer Navigation Fix name which is not part of the normal published ATC route (although the underlying turning point is, in this case).
- When CNFs are published in state AIP sources, they will be included in paper charts [in square brackets]; if they are created by Jeppesen, they will only be found in the GPS database

ARINC 424 name and coding conventions

6. Introduction to Computer Navigation Fixes (CNF)

• CNFs are created when a waypoint required for coding Terminal or Approach Procedures is

- either marked in paper charts without an identifier, or with an identifier too “generic” to meet ARINC 424 standards
- or does not exist in paper procedure charts
- CNF identifiers defined by state AIS sources are included in paper charts [in square brackets], CNFs defined by Jeppesen appear only in the database

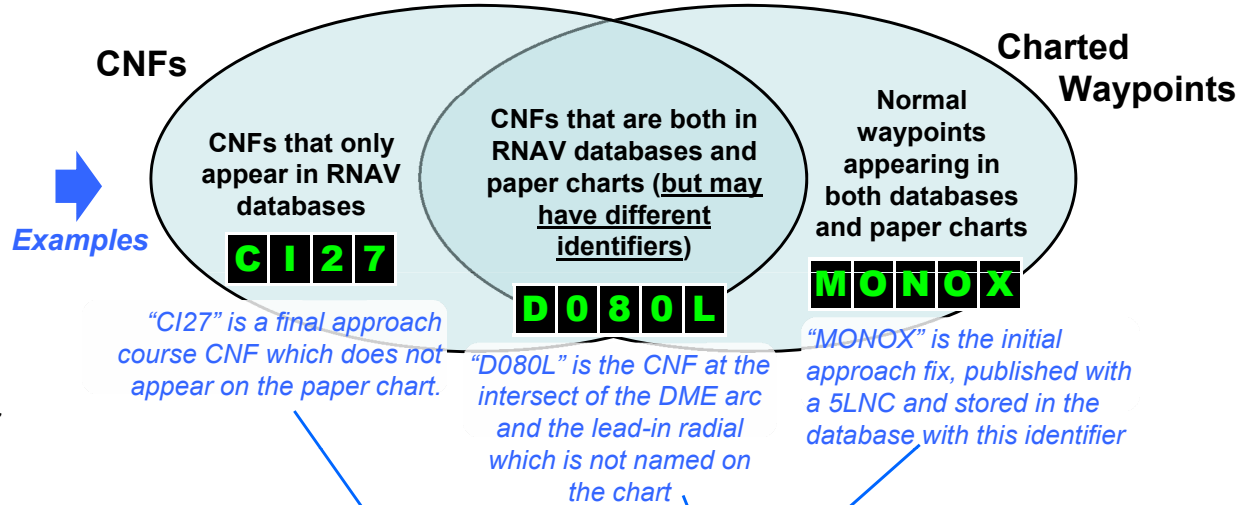

LFBZ ILS 27 Procedure, MONOX transition: Garmin GNS530W display extracts

Other CNFs, see next pages

131° is the initial tangential track along the DME arc from MONOX

Approach ILS 27			
MONOX	In	049°	
dme arc	BTZ	12.0°	
D080L		131°	8.2°
C127		271°	4.0°

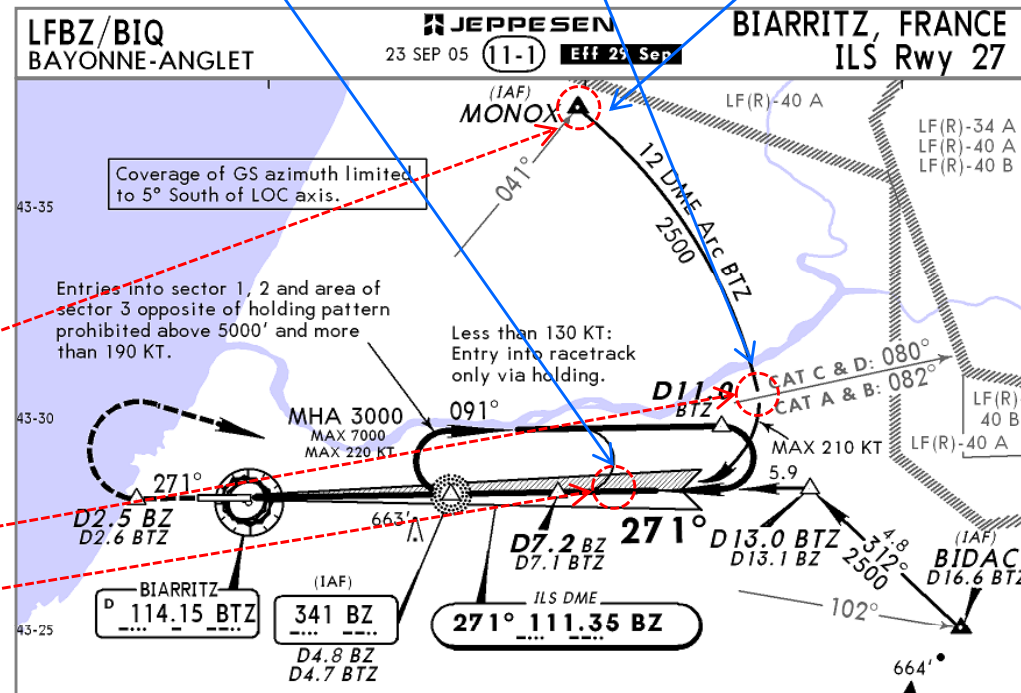

ARINC 424 name and coding conventions

7. Procedure “bearing/distance” CNFs

- In the previous example, why is the identifier “D080L” used for the CNF at the end of the DME arc?



Procedure waypoint “bearing/distance” CNF convention

- In SIDs, STARs and Approaches, this convention is used to create an identifier for unnamed fixes or DME fixes
- The identifier is always a 5 character alphanumeric in the format:

D n n n a

first character is always “D”

middle 3 digits are the radial from the reference VOR (or other reference point)

last character is a letter code for the distance from the reference point

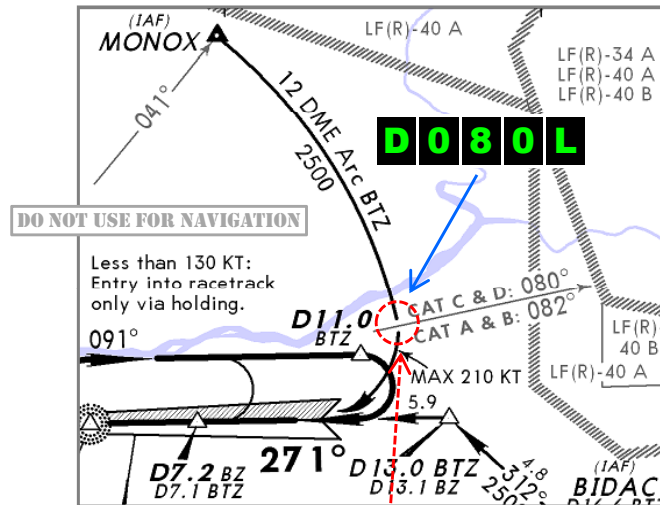

Garmin GNS530W display extracts

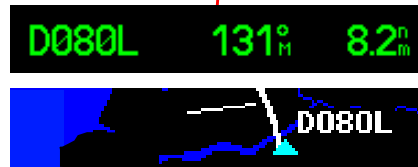

- Hence, in the example above, the waypoint on the BTZ 080 radial and 12nm DME arc is given the identifier “D080L”
- Procedure “bearing/distance” CNFs are only unique within a TMA
- Note that this 080 radial represents the CAT C & D procedure: the Jeppesen database does not code any CAT A & B procedures

ARINC 424 name and coding conventions

8. Airport CNFs

- In the previous example, why is there a CNF called “CI27” on the final approach track prior to the FAF?



Airport CNF convention

- This convention allows CNFs to be created for all the fixes RNAV equipment needs to provide guidance throughout an approach procedure, which may not be published or have an ARINC 424 compatible name
- The identifier is a 4 or 5 character alphanumeric in the format:

1st letter defines the waypoint type

a a n n a

If there are parallel runways, the 5th character is an L, C or R runway suffix

2nd letter defines the approach type, if there are multiple approaches to this runway, otherwise it is the 2nd letter of the waypoint type code

2 digits are the runway identifier

- The various codes for the waypoint type and approach type are detailed on the next page

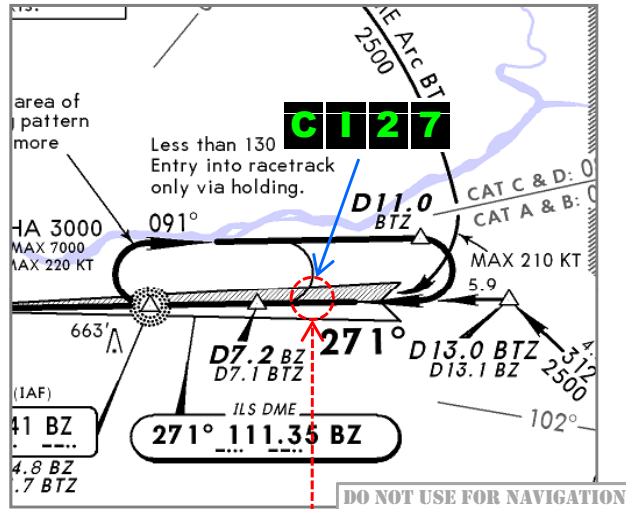

Garmin GNS530W display extracts

CI27 271° 4.0_m



- In the “CI27” example above, the “C” indicates a final approach course fix, the “I” indicates an ILS procedure, and the “27” that the procedure is for runway 27
- Airport CNFs are unique to an individual Airport only. In the example above, there will only be a single instance of a CNF identifier “CI27” associated with LFBZ. Many other airports, including ones in the same TMA, can have an identically named CNF

ARINC 424 name and coding conventions

9. Airport CNF codes



First two characters of the CNF identifier are the Waypoint Type

Initial Approach Fix	AF
Intermediate Approach Fix	IF
Final Approach Course Fix	CF
Final Approach Fix	FF
Missed Approach Point	MA
Step-Down Fix	SD
Runway Centreline Fix	RC
Touchdown point	TD
Runway Fix	RW
Outer Marker	OM
Middle Marker	MM
Inner Marker	IM
Back course Marker	BM

Rarely used

CNFs unique to a runway, so no need for a single letter code

If an approach marker has an identifier, that will be used in preference to this CNF convention

First character of the CNF identifier is the Waypoint Type

Initial Approach Fix	A_
Intermediate Approach Fix	I_
Final Approach Course Fix	C_
Final Approach Fix	F_
Missed Approach Point	M_
Step-Down Fix	S_
Runway Centreline Fix	R_
Touchdown point	T_



Second character of the CNF identifier is the Procedure Type

_I	ILS Approach
_L	Localiser Approach
_D	VOR/DME Approach
_V	VOR Approach
_N	NDB Approach
_Q	NDB/DME Approach
_R	RNAV Approach
_P	GPS Approach



These are 8 of the most common types, see next page for the full list of 25

- ➔ The only unfamiliar, but frequently used, waypoint type is the Final Approach Course (or Capture) fix, CF or C_
- Many older RNAV systems can only provide guidance from one waypoint to another. Without the CF/C_ fix, they could not provide track guidance along the final approach to the FAF following an intercept (eg. a base turn or radar vectors) that did not commence with a published waypoint
- Hence, many approach procedures are coded with a CF/C_ fix after the intercept of the final approach track and before the FAF

Reference: extract from Jeppesen NavData documentation

Source: www.jeppesen.com > GPS NavData Services > Documentation and Support



Full List of 25 Approach types	Waypoint types	Matrix of Waypoint and Approach type combinations				
A. Approach Transition B. LLZ Back course Approach C. LORAN Approach D. VOR/DME Approach E. VOR Circle-To-Land Approach F. FMS Approach G. IGS (Instrument Guidance System) Approach	ILS(I) AI II CI FI MI TI RI SI Step-Down	ILS(L) AL IL CL FF ML TL RL SL	ILS(B) AB IB CB FB MB TB RB SB	VOR(D) AD ID CD FD MD TD RD SD	VOR(V) AV IV CV FV MV TV RV SV	VOR(S) AS IS CS FS MS TS RS SS
H. Helicopter Approach I. ILS Approach J. LLZ only Circle-To-Land Approach K. LLZ Back course Circle-To-Land Approach L. Localizer only Approach M. MLS Approach N. NDB Approach	NDB(N) AN IN CN FN MN RN SN Step-Down	NDB(Q) AQ IQ CQ FQ MQ RQ SQ	MLS(M) AM IM CM FM MM RM SM	RNAV(R) AR IR CR FR MR TR RR SR	TACAN(T) AT IT CT FT MT TT RT ST	LORAN(C) AC IC CC FC MC TC RC SC
P. GPS Approach Q. NDB/DME Approach R. RNAV Approach S. VOR Approach with DME Facility T. TACAN Approach U. NDB Circle-To-Land Approach V. VOR Approach (Non-DME Facility)	IGS(G) AG IG CG FG MG TG RG SG Step-Down	LDA(X) AX IX CX FX MX TX RX SX	SDF(Z) AZ IZ CZ FZ MZ TZ RZ SZ	FMS (F) 1F 2F 3F 4F 5F 6F 7F 8F	GPS(P) AP IP CP FP MP TP RP SP	HEL(H) AH IH CH FH MH TH RH SH
W. MLS Type A Approach X. LDA (Localizer Directional Aid) Approach Y. MLS Type B and C Approach Z. SDF (Simplified Directional Facility) Approach	VOR C-T-L(E) AE IE CE FE ME TE RE SE	NDB C-T-L(U) AU IU CU FU MU TU RU SU	LOC C-T-L(J) AJ IJ CJ FJ MJ TJ RJ SJ	BAC C-T-L(K) AK IK CK FK MK TK RK SK	MLS (W) AW IW CW FW MW TW RW SW	MSL (Y) AY IY CY FY MY TY RY SY

ARINC 424 name and coding conventions

10. Summary of “point” terminology

- The terminology around “types of point” can be confusing, because it is not always consistently defined and applied. The tables below provides some guidance on the use of various terms

Enroute and Terminal points

Term	Definition	On paper chart	In GPS unit
Fix	<u>Specifically</u> , a geographical point defined by reference to radio aids, also, <u>in general</u> , includes any of the below	& name identifier	 & identifier <i>usually one symbol used for all fix and waypoint types, except radio aids</i>
Intersection	A fix defined by the intersection of two VOR radials	& DME distance or unnamed	
RNAV Waypoint	A geographic point defined by coordinates rather than radio aids; the RNAV equivalent of a fix	& identifier (<i>fly-by example</i>)	
Waypoint	<u>In general</u> , any of the above, also locations of a radio aid. Sometimes <u>specifically</u> an RNAV waypoint	Any of the above	
Computer Navigation Fix (CNF)	A fix or waypoint used in RNAV databases but not for ATC or flight plan filing purposes	Identifier, if shown and different from the published name, will be in [square brackets]	
Database Identifier	<u>In general</u> , the primary record name in an RNAV database for any of the above. Sometimes, <u>specifically</u> the name of a CNF		

Approach waypoints

Term	Definition	Traditional procedure	RNAV procedure
IAF	Initial Approach Fix, Intermediate Fix and Missed Approach Point definitions are <u>exactly the same</u> in RNAV procedures as in ‘traditional’ IFR approaches		
IF		& name	& name
MAP (or MAPt)		..or navaid symbol & name	..or navaid symbol & name
FAP	Final Approach Point – used only in a <u>precision</u> approach, the point at which the intermediate approach altitude or height intersects the glide path	In paper charts, <u>not defined as a fix</u> , but a DME distance may be marked at the FAP In databases, an “FF/F_” CNF is defined at the FAP	
FAF	Final Approach Fix – used only in a <u>non-precision</u> approach (NPA), the fix which defines the start of the descent to MDA/MDAH	Fix and fix name depicted on paper charts and databases (may be a CNF identifier for a DME fix) <i>NPAs without a fix (eg. NDB approach based only on timing) will have a “FF/F_” CNF defined in the database</i>	
<p>Note: in the late 1990s, it was proposed that the waypoints in RNAV approaches should be called “IAWP, IWP, FAWP, MAWP” (with “WP” for Waypoint replacing “F” for Fix). This new terminology was abandoned, but some older publications and charts still use the “-WP” notation</p>			

- ➔ This completes the Databases and Coding section
- The next section will review how ARINC 424 is used to code both traditional procedures (the “database overlay”) and RNAV procedures, and how GPS units provide procedure guidance

1. RNAV and RNP theory
 - a. Introduction
 - b. The Path-Terminator
 - c. RNAV procedure design
 - d. RNP principles
 - e. RNAV and RNP applications
2. GPS Navigators and their application to RNAV
 - a. The GPS system
 - b. Databases and Coding
 - c. Procedures**
 - d. Error detection and warnings
3. P-RNAV Terminal Procedures
 - a. P-RNAV requirements and approvals
 - b. P-RNAV training topics
 - c. P-RNAV operations
4. RNAV(GPS) Approach Procedures
 - a. GPS procedure types
 - b. GPS approach requirements and approvals
 - c. GPS approach operations
5. Avionics training
6. Simulator and/or Flight training

- There is significant variation in the methods and structures used in instrument procedure design, and the corresponding chart titles and text
- These designs and descriptions change over time, particularly as RNAV is being implemented in Europe. When new conventions are introduced, older charts are often not systematically updated
- Hence, it is not possible to give an exhaustive “set of rules” or an exhaustive set of examples to cover every permutation of charts, procedures and coding
- This section of the manual is intended as a guide, not an complete rule book
- **A current, approved chart is the definitive source of navigation data; and, in operations where this is approved, a suitable, current RNAV database may be used if it agrees with the charted information. In the event of a discrepancy, the charted procedure takes precedence.**
- In cases where an RNAV database is required (eg. P-RNAV, or GPS approaches), a discrepancy between the database and chart means that the RNAV procedure may not be flown, and an alternative must be used.
- In the event of any discrepancy between this document’s description of IFR navigation practice and methods and that of any approved chart, database or product manual, clearly, the published, approved sources must take precedence
- Also, self-evidently, none of the Jeppesen charts or Garmin GPS screen shots in this manual may be used for navigation purposes

Procedure titles and names

1. Overview

- Procedure names in Airway Manual paper charts are straightforward in principle, but a variety of different titles are used for terminal procedures, and there is some variation in how approach procedure names are constructed

3 kinds of procedure →	Departures	Arrivals	Approaches
	collectively known as “Terminal Procedures”		
Paper chart procedure “titles”	<ul style="list-style-type: none"> • “SID” • “Departure”, • FAA charts also use “Departure Procedure” and “DP” 	<ul style="list-style-type: none"> • “STAR” • “Arrival” • “Transition” • “Initial Approach” • Continuation charts between a STAR and an approach 	<ul style="list-style-type: none"> • Many types of approach: ILS, VOR, SRA, RNAV etc • Some different standards for how names are constructed (eg. “ILS DME” vs “ILS” with DME requirement specified in chart notes)
Names and identifiers used in paper charts	<ul style="list-style-type: none"> • Procedure type in chart title • Procedure name on chart, plus..... • Procedure ICAO identifier in (curved brackets) • Database identifier in [square brackets] if different from ICAO identifier 		<ul style="list-style-type: none"> • Chart title has the full procedure name

- The coding of procedure identifiers in GPS databases is simpler. All Departure and Arrival procedure records have 3 selection attributes (or ‘fields’) and all approaches have 2 attributes



Procedure identifiers used in GPS databases	<ul style="list-style-type: none"> • Departure identifier • Transition identifier • Runway identifier 	<ul style="list-style-type: none"> • Arrival identifier • Transition identifier • Runway identifier 	<ul style="list-style-type: none"> • Approach identifier (which also specifies the runway) • Transition identifier or “Vectors”
--	--	--	---

Note that many procedures will only have one transition and/or runway selection available

- ➔ **The key links between published procedures and database coded procedures are the procedure identifier and transition identifier**
- **If the ICAO and database identifiers are not the same, the database identifier will be included on the paper chart in [square brackets]**

GPS databases encode both RNAV and “traditional” procedures

- In paper chart form, procedures are ‘conventional’ or ‘traditional’ (in the sense of requiring radio navigation) by default, unless specifically designated as RNAV procedures in the chart title, procedure name or chart notes
- Generally, all published, route-based procedures are coded in GPS databases (omnidirectional and radar procedures are not)
- From the point of view of “coding style” and how GPS procedure guidance may be used, this results in three kinds of database-coded procedure:

	1. “Database Overlays”	2. “Published Overlays”	3. RNAV Procedures
	Traditional, non-RNAV procedures coded in the database using all the ARINC 424 path-terminators and CNFs as required	“Hybrid” procedures, where the published charts denote that radio navigation <u>or</u> RNAV guidance may be used	Procedures designed and published for use only with RNAV.
Terminal Procedures	<ul style="list-style-type: none"> • In Europe, most terminal procedures are still ‘traditional’ (except in the major TMAs that use B-RNAV or P-RNAV procedures) • These are coded as database overlays 	<ul style="list-style-type: none"> • There are a small number of published overlay terminal procedures. They typically appear on separate chart pages that depict the overlaid RNAV waypoints, but use the <u>same ICAO procedure identifiers</u> as the conventional SID or STAR chart 	<ul style="list-style-type: none"> • B-RNAV or P-RNAV procedures • Coding uses RNAV waypoints and mainly the CF and TF path-terminators, with few, if any, CNFs needed
Approaches	<ul style="list-style-type: none"> • Most approaches in Europe are based on conventional nav aids • These are coded in GPS databases, providing advisory track guidance throughout the final approach and missed approach procedures 	<ul style="list-style-type: none"> • A small number of non-precision approach procedures in Europe are published overlays, with a title that includes an RNAV method of navigation (eg. “VOR DME or GPS Rwy 27”) 	<ul style="list-style-type: none"> • Non-precision GPS approaches are increasingly common in Europe. A variety of names are used (RNAV, GNSS, GPS) • All the CNFs required are usually published on the paper charts (including Airport CNFs)
Use of GPS for primary navigation guidance?	<p>Generally, no. GPS guidance is supplemental to radio aids. <i>Some operators/installations may be approved to use database overlays as primary guidance: details are beyond the scope of this course</i></p> 	<p>RNAV <u>optional</u>, if approval requirements are met</p> 	<p>RNAV <u>required</u>; radio aids only used for gross error check. Appropriate RNAV approval requirements must be met</p> 

- ➔ **Note that the database display of procedure names, waypoints and path-terminators does not provide any particular distinction between RNAV and non-RNAV procedures**
- **GPS units will generally provide a message alert when “advisory only” guidance is activated for a non-RNAV procedure**

Procedure titles and names

2. Background on terminal procedure titles

- Terminal procedures always serve to provide safe obstacle and terrain clearance for flight in IMC
 - “general” procedures, serving mainly this purpose, may be published in text and/or chart form, and may not have ICAO identifiers or even specific route names
- Terminal procedures may also be used for ATC and flight planning purposes: to standardise the transition between the enroute airway network and TMAs, and to standardise routes within TMAs, so that traffic flows may be efficiently managed and ATC communications simplified
 - procedures also serving this purpose are generally called “standard” instrument departures (SIDs) and “standard” arrivals (STARs)
- In practice, in Europe, most terminal procedures are SIDs and STARs, and “general” procedures, without the formal ATC function, are labelled “Departures” and “Arrivals”
- However, the nomenclature of terminal procedure titles is not perfectly standardised
- In particular, busy airports often use a more complex set of arrival procedure structures than just the basic model of STARs from the enroute segment to the IAF. These airports may also have arrival charts with a variety of titles such as “Arrivals”, “Transitions”, “Initial Approaches” etc. which have the same ATC status as STARs
- The FAA also uses some slightly different procedure titles which are not detailed in this manual

 • **The main European standards and structures are described in the next pages**

Procedure titles and names

3. Departures

Departure titles in Jeppesen charts:

	'general' IFR procedures	standard IFR procedures
Traditional	DEPARTURE	SID
RNAV	RNAV DEPARTURE (not used at present)	RNAV SID also RNAV SID (OVERLAY)

SID name format in Jeppesen charts:

waypoint **1 digit** **1 letter** *(ICAO designator)* *[database identifier]*

↓ ↓ ↓ ↓ ↓

Example: **BUZAD** **THREE** **JULIETT** **(BUZAD 3J)** **[BUZA3J]**

⏟ ⏟ ⏟ ⏟ ⏟

In Europe, usually the full name of the waypoint or fix at the end of the procedure

Version number of the procedure, increased by 1 every time a change is made, cycling back to 1 after 9

Often the code letter for a particular departure runway. More than one letter may be used for the same runway, and the letter codes may have another meaning (eg. routes for Jet vs Prop aircraft)

The ICAO procedure "designator" is used for flight plan filing. It uses the ICAO identifier for the final waypoint instead of its full name (if these are different, eg. Lambourne Three Alpha vs. LAM 3A)

The ARINC 424 procedure name is limited to 6 characters. If the name of the final fix is a 3 letter VOR ident, the ICAO procedure identifier will be 5 characters (3+1+1) and used as the database identifier. If the final waypoint name is a 5LNC (as in the example above), the database identifier will drop the last character of the 5LNC, and be printed separately in [square brackets]

- ➔ The structure of instrument departures is relatively simple and homogenous, they all start on the runway and generally end with an enroute waypoint

Example of a (non-SID) Departure

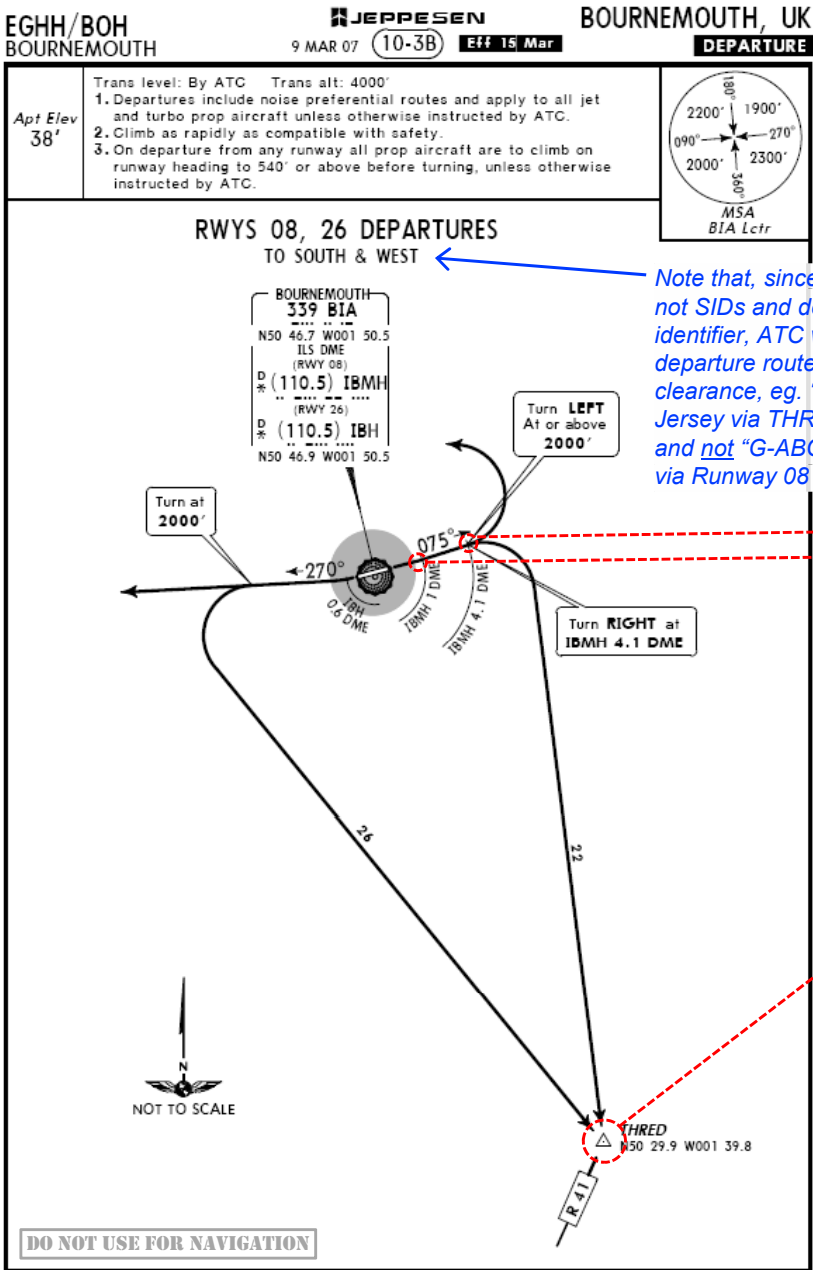

DEPARTURE RWYS 08, 26 DEPARTURES TO SOUTH & WEST

Garmin GNS530W procedure selection page



The South departure is coded because it has a specific route (to THRED) and "South" is used as the database identifier even though there is no ICAO identifier. The West departure is not coded, since it lacks a specific route.

Garmin GNS530W flight plan waypoint list

Departure SOUTH			
Runway ID	RW08		
Bearing/Distance CNFs	D078B	078^M	1.0^N
	D078E	075^M	3.1^N
5LNC	THRED	175^M	18.4^N

CNF comment

Note that the Procedure bearing/distance CNF names in this example appear to be referenced to the BIA NDB at the centre of the airport, the "078" bearing implicit in both names is only approximate, the alphabet distance codes are more accurate. The naming convention's purpose is to create a distinct identifier for CNFs but no navigation meaning should be inferred from the identifier text (eg. "the next waypoint is D078B so I must fly a track of 078 degrees") – navigation data is accurately depicted in the path-terminator information to the right of the waypoint name and the GPS Nav or Map pages provide the approved source of guidance

Example of a conventional SID

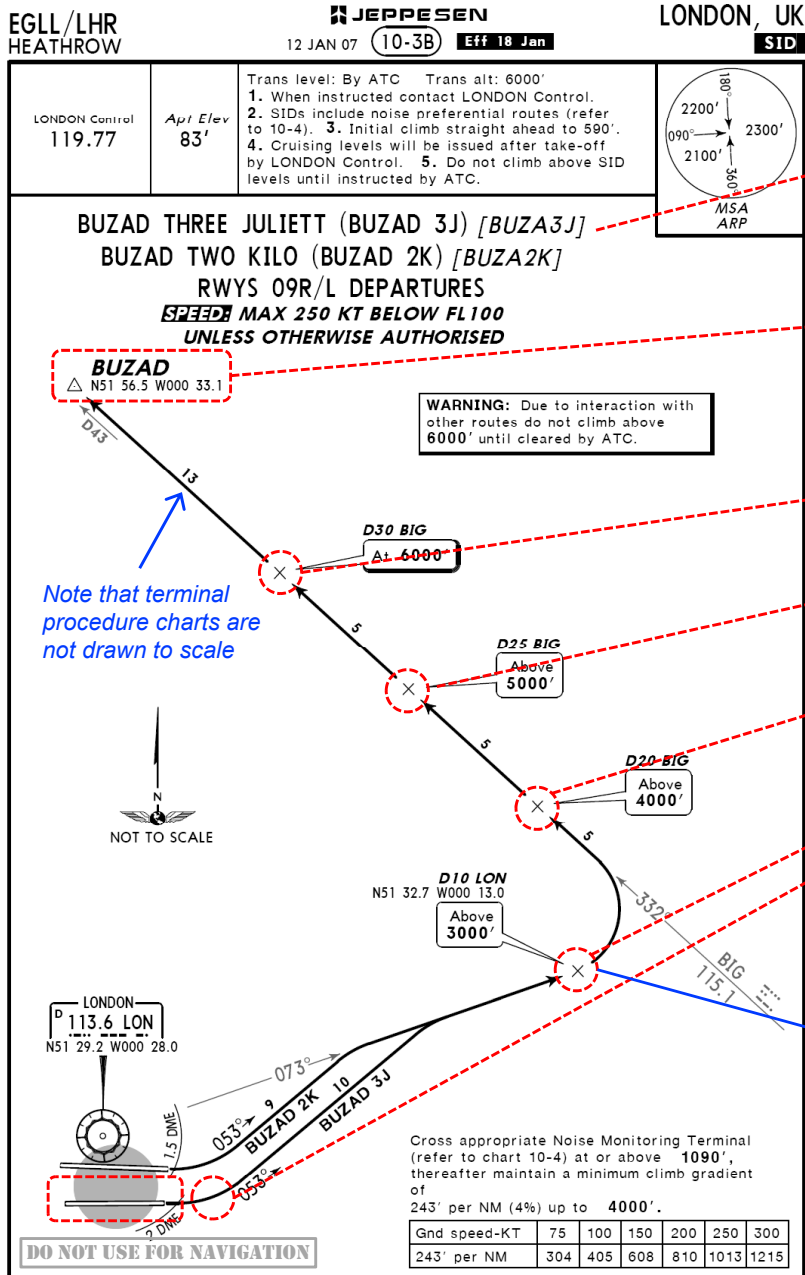

SID

BUZAD THREE JULIETT (BUZAD 3J) [BUZA3J]

Garmin GNS530W procedure selection page

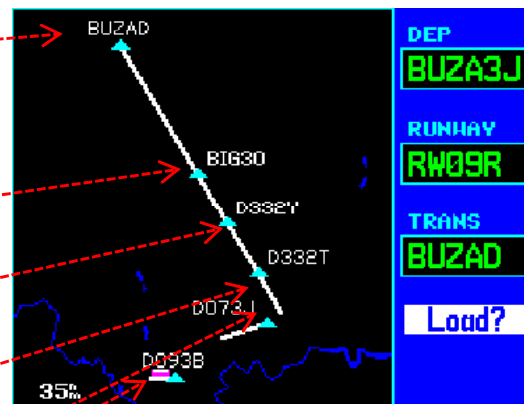

DEP	BUZA3J
RUNWAY	RW09R
TRANS	BUZAD
Load?	

Garmin GNS530W flight plan waypoint list

Departure BUZA3J			
Runway ID	RW09R		
Bearing/Distance CNFs	D135B	092°M	2.0 ⁿ 2.0 ⁿ
	D073J	073°M	4.0 ⁿ 6.0 ⁿ
	D332T	332°M	4.0 ⁿ 10.0 ⁿ
	D332Y	331°M	5.0 ⁿ 15.0 ⁿ
Enroute CNF	BIG30	331°M	5.0 ⁿ 20.0 ⁿ
5LNC	BUZAD	331°M	12.8 ⁿ 32.8 ⁿ
	Enroute		

CNF example

On the paper chart, "D10 LON" is a fix on the LON 073 radial and 10 DME. In the Procedure bearing/distance CNF convention, this results in the identifier "D073J", where J is the alphabetical code for 10nm.

"BIG30" uses the Enroute CNF convention because the DME distance from its reference VOR exceeds the 26nm available in the Procedure bearing/distance CNF alphabetical code

Example of an RNAV SID

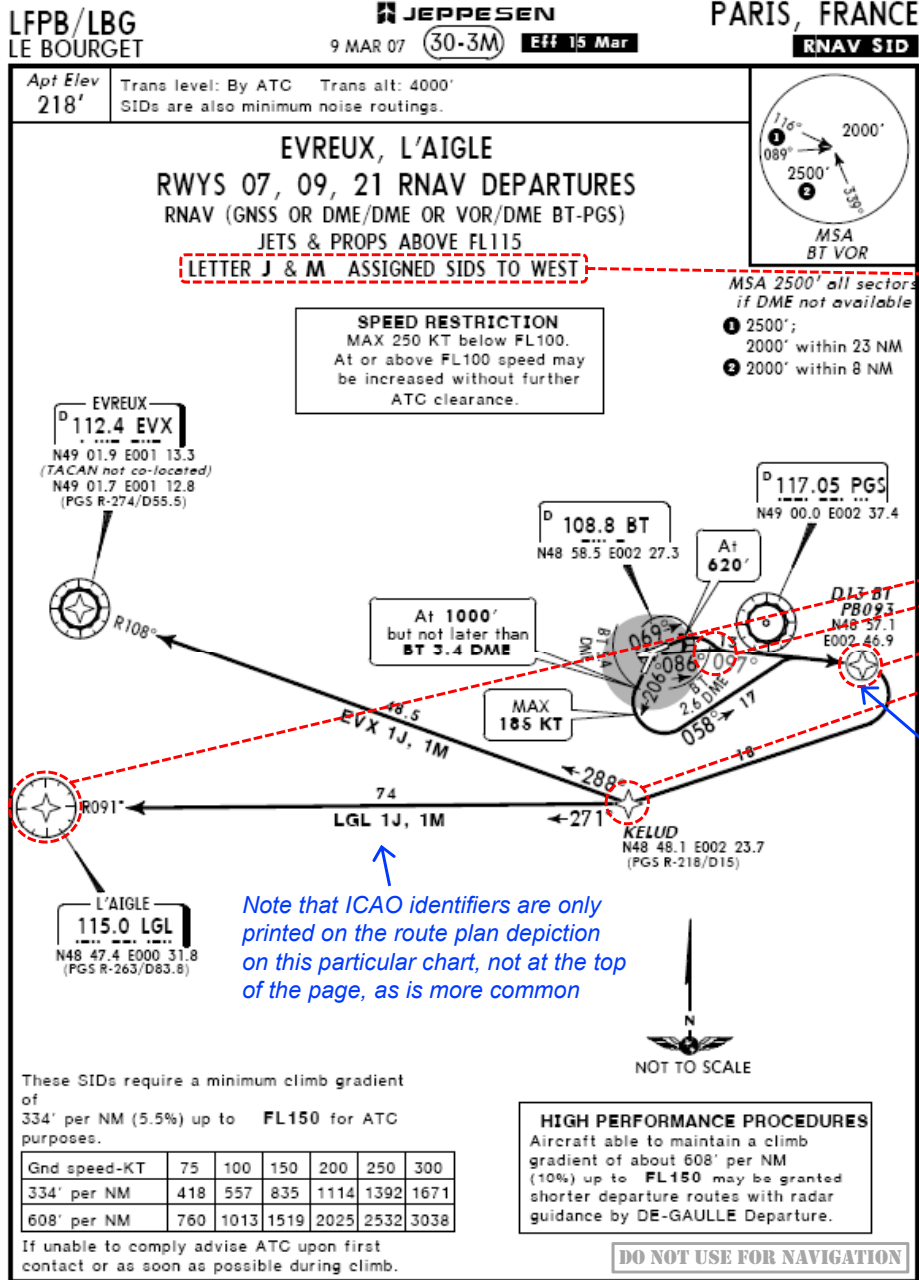

RNAV SID

EVREUX, L'AIGLE
RWYS 07, 09, 21 RNAV DEPARTURES
RNAV (GNSS OR DME/DME OR VOR/DME BT-PGS)

Question 1:
Is this a P-RNAV or B-RNAV route, it's not explicit on the chart? (see next page)

Question 2:
What is the difference between the "J" and "M" designators? (see next page)

Garmin GNS530W procedure selection page

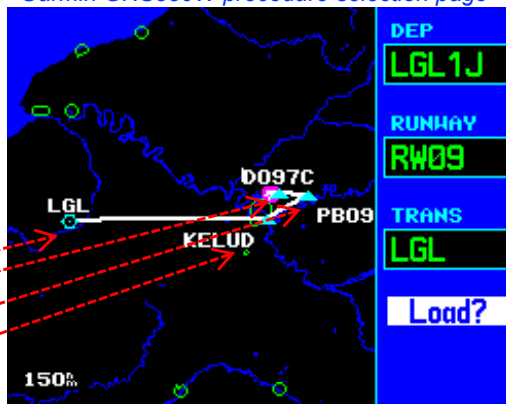

Note that multiple runways share the same departure procedures, hence the runway field has 3 options available in the procedure selection page

Garmin GNS530W flight plan waypoint list

Departure LGL1J			
Runway ID	RW09		
Bearing/Distance CNFs	D097C	086° _M 4.0 _{NM}	4.0 _{NM}
	PB093	097° _M 10.4 _{NM}	14.4 _{NM}
5LNC	KELUD	241° _M 17.8 _{NM}	32.2 _{NM}
VOR ident	LGL	271° _M 74.0 _{NM}	106 _{NM}

Note that PB093 is a Fly-Over waypoint. These are only used in RNAV procedures when turn anticipation is undesirable; in this case, the large track change would result in a very early turn, especially for fast aircraft, if it were a Fly-By waypoint

CNF comment

Note that the bearing/distance CNF identifier "D097C" is referenced from the BT VOR to the northeast of the Le Bourget. The path-terminator data correctly identifies the track to this waypoint as 086 degrees after take-off. The along-track distance is coded as 4nm from the start of the take-off roll. The turning point for the 097 degrees track to "PB093" is published on the chart as 2.6nm DME distance from the BT VOR. This, rather than the CNF, should be used for primary guidance. Note "PB093" is a tactical RNAV waypoint identifier, not a CNF.

- Page 30-3 of the LFPB charts has departure instructions that are helpful for interpreting the individual SID pages

LFPB/LBG LE BOURGET 19 OCT 07 (30-3) PARIS, FRANCE SID

DEPARTURE INSTRUCTIONS

1. RNAV DEPARTURES

1.1. Protection
Initial departures are only protected in conventional navigation. RNAV departures are protected VOR/DME and/or DME/DME and GNSS RNAV for aircraft CAT A, B, C and D and meet B-RNAV requirements.

1.2. Equipment
The equipment must be approved for RNAV operations based on minimum requirements specified in the aeronautical documentation. ATC provides radar functions.

2. PARTICULAR RULES FOR DEPARTURES (CONVENTIONAL SID OR DIRECT PLAN)

2.1. Non RNAV equipped aircraft below FL115
Specify FPL item 15:
- to north sector: DCT MTD then DCT first point joining the en-route network.
- to east sector: DCT NIPOR or DCT BAXIR.
- to south sector: SID PTV, MONOT or DORDI.
- to west sector: DCT EVX or DCT LGL.

After initial departure, depending on which runway has been used for take-off:
- to north sector: radar guidance to MTD.
- to east sector: radar guidance to CGN R-085 to proceed NIPOR or radar guidance to CLM R-096 to proceed BAXIR.
- to south sector: radar guidance to proceed SID PTV, MONOT or DORDI.
- to west sector: radar guidance to proceed EVX or LGL.

PROP aircraft destination UIR must indicate:
- after PTV: DCT AGOPA or DCT ERIXU.
- after MONOT: DCT LATRA, DCT OKASI or DCT PILUL.

2.2. Departures RWY 07
The crews attention is drawn to the proximity of the final approach course to RWY 08R at Charles-De-Gaulle.

2.3. Departures RWY 09
The crews attention is drawn to the proximity of the final approach course to RWY 08R at Charles-De-Gaulle.
Due to risk of confusion between RWY 07 and RWY 09 crews are requested to check their magnetic track after lining up and before take-off.

3. SID DESIGNATION

Letter C assigned when westerly take-offs/landings (same direction) in use at Orly and Charles-De-Gaulle.
Letter F assigned when easterly take-offs/landings (reverse direction) in use at Orly and westerly take-offs/landings (same direction) in use at Charles-De-Gaulle.
Letter J assigned when easterly take-offs/landings (same direction) in use at Orly and Charles-De-Gaulle.
Letter M assigned when westerly take-offs/landings (reverse direction) in use at Orly and easterly take-offs/landings (same direction) in use at Charles-De-Gaulle.

Question 1: (referring to previous page)

Is this a P-RNAV or B-RNAV route, it's not explicit on the chart?

1. RNAV DEPARTURES

1.1. Protection

Initial departures are only protected in conventional navigation. RNAV departures are protected VOR/DME and/or DME/DME and GNSS RNAV for aircraft CAT A, B, C and D and meet B-RNAV requirements.

1.2. Equipment

The equipment must be approved for RNAV operations based on minimum requirements specified in the aeronautical documentation. ATC provides radar functions.

- Paragraph 1.1 describes how the procedures are designed to protection criteria suitable for B-RNAV GPS, however 1.2 specifies that AIC/AIP sources must be checked for the minimum requirements; which are B-RNAV approval in this case. A P-RNAV requirement would normally be specified here and on the individual RNAV chart pages - see Section 3.

Question 2: (referring to previous page)

What is the difference between the "J" and "M" designators?

3. SID DESIGNATION

Letter C assigned when westerly take-offs/landings (same direction) in use at Orly and Charles-De-Gaulle.
Letter F assigned when easterly take-offs/landings (reverse direction) in use at Orly and westerly take-offs/landings (same direction) in use at Charles-De-Gaulle.
Letter J assigned when easterly take-offs/landings (same direction) in use at Orly and Charles-De-Gaulle.
Letter M assigned when westerly take-offs/landings (reverse direction) in use at Orly and easterly take-offs/landings (same direction) in use at Charles-De-Gaulle.

- The final letter of the procedure identifier, in the case of LFPB, does not specify a particular departure runway but the departure direction (W or E) and whether Orly departures are in the same or reverse direction. This relates to the proximity of the 3 large Paris airports

Example of a SID with a published RNAV Overlay

EDDK/CGN
COLOGNE-BONN

JEPPESEN COLOGNE-BONN, GERMANY
1 FEB 08 (10-3) Eff 14 Feb SID

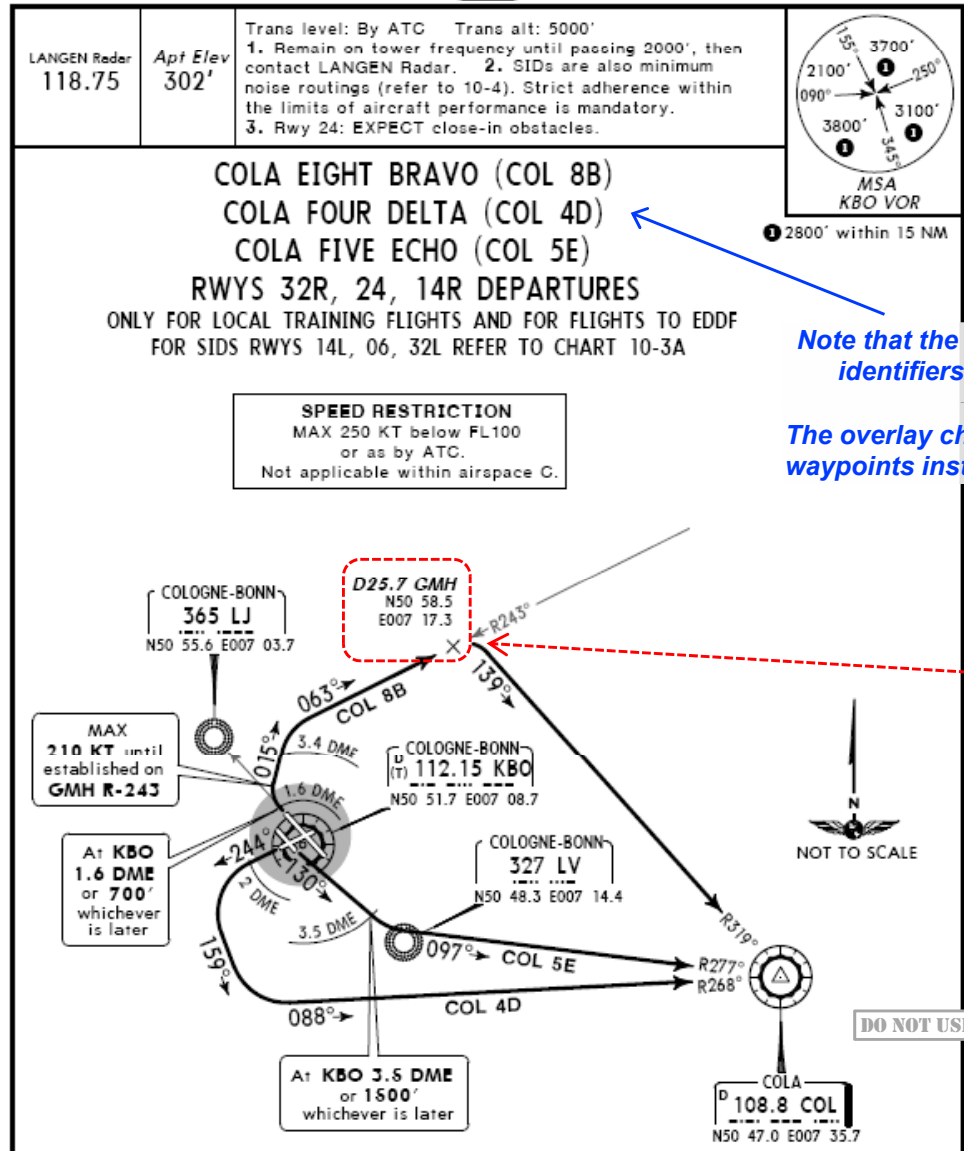

EDDK/CGN
COLOGNE-BONN

JEPPESEN COLOGNE-BONN, GERMANY
1 FEB 08 (10-3N) Eff 14 Feb RNAV SID (OVERLAY)

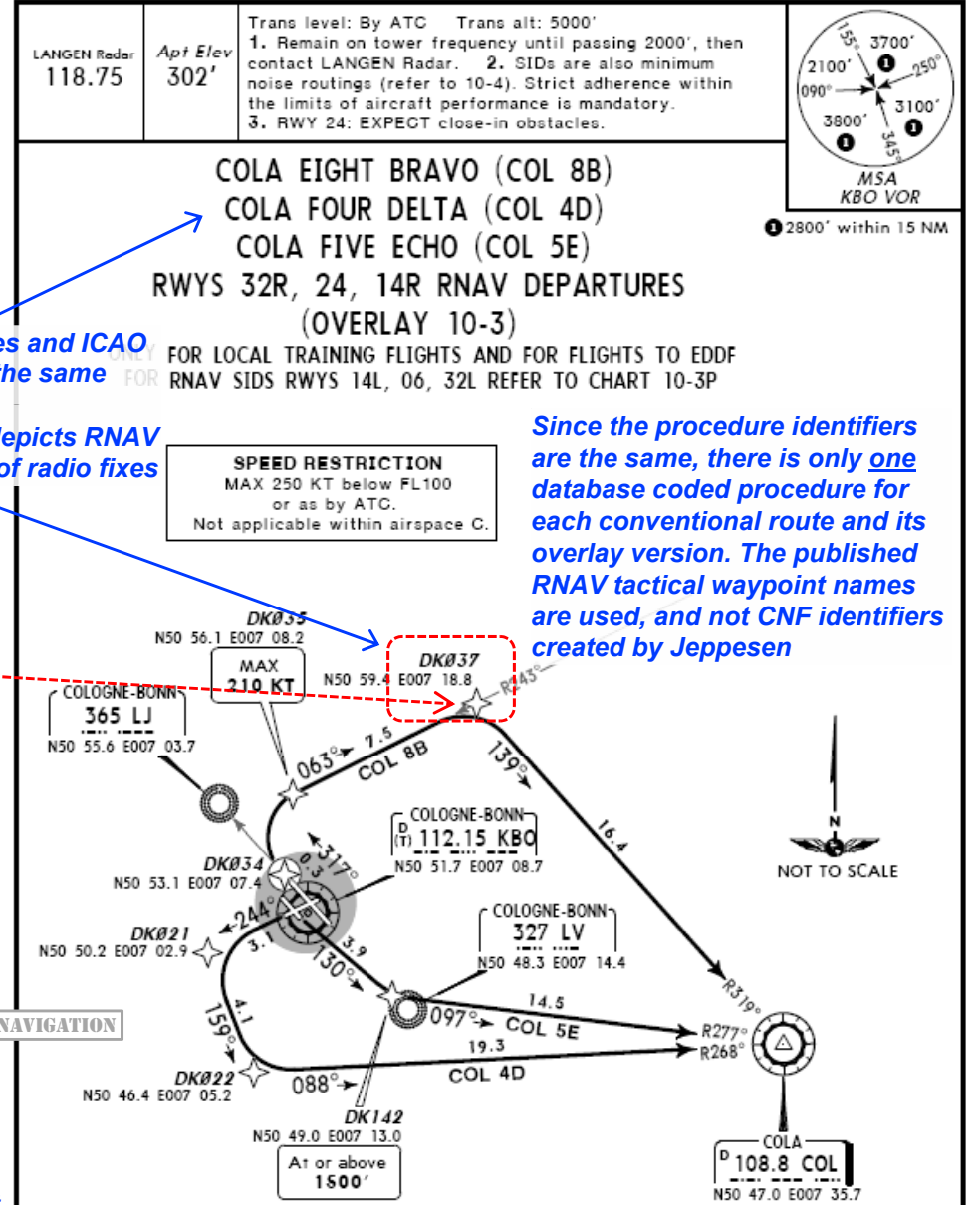

Note that the routes and ICAO identifiers are the same

The overlay chart depicts RNAV waypoints instead of radio fixes

Since the procedure identifiers are the same, there is only one database coded procedure for each conventional route and its overlay version. The published RNAV tactical waypoint names are used, and not CNF identifiers created by Jeppesen

Note: State AIP charts often publish SIDs for the same runway on the same chart. In this case, the RNAV overlay is only detailed in the in the German AIP text page following the 32R SID chart

Example of a SID followed by Transition routes

LSGG Geneva

- Geneva is an example (relatively rare in Europe) where some SIDs are followed by a number of different Transition routes connecting to the airways around the TMA



LSGG/GVA GENEVA		JEPPESSEN GENEVA, SWITZERLAND	
13 APR 07 (10-3G)		SID	
GENEVA Departure (R) 119.52	Apt Elev 1411'	Trans level: By ATC Trans alt: 7000'	
1. Contact GENEVA Departure when instructed. 2. SIDs are also minimum noise routings. Strict adherence within the limits of aircraft performance is mandatory. 3. To expedite traffic, expect line-up clearances at intersections unless operations require full runway length.			
KONIL FOUR CHARLIE (KONIL 4C) [KONI4C]		7000' 241'	
KONIL TWO DELTA (KONIL 2D) [KONI2D]			

waypoint digit letter (ICAO designator) [database identifier]

LSGG/GVA GENEVA		JEPPESSEN GENEVA, SWITZERLAND	
6 JUL 07 (10-3N)		TRANSITION	
GENEVA Departure (R) 119.52	Apt Elev 1411'	Trans level: By ATC Trans alt: 7000'	
TRANSITION ROUTES AFTER KONIL			

- The SIDs have the usual ICAO designators and are coded in the database with appropriate identifiers

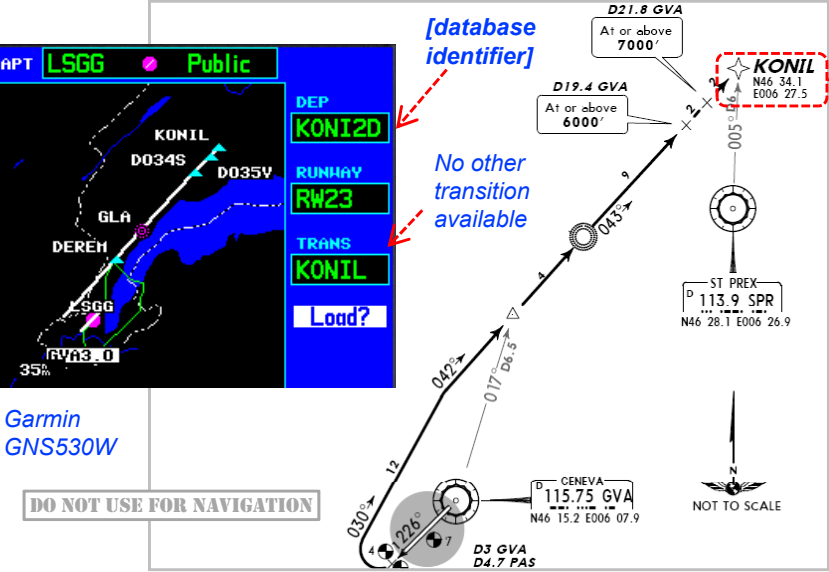
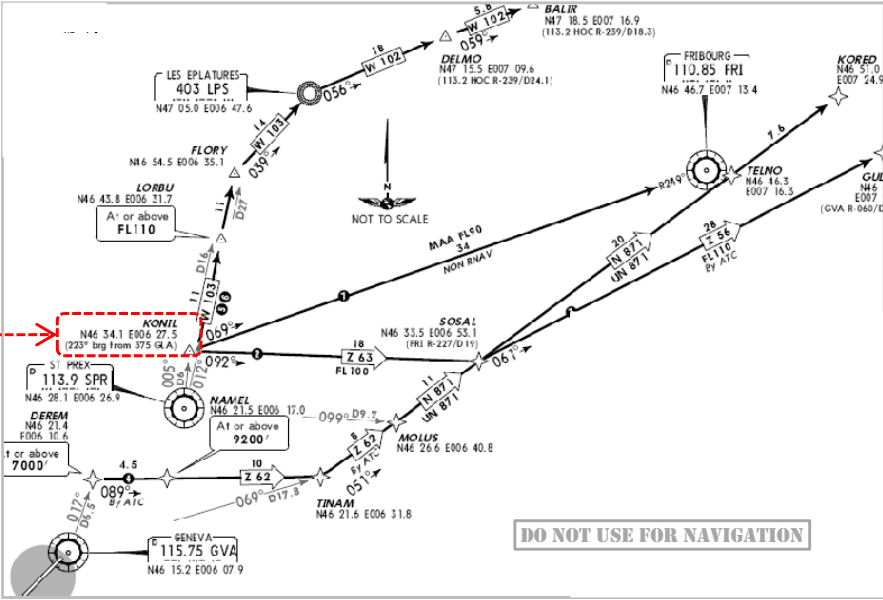

- The transitions are B-RNAV ATS routes, published in the paper chart but, in this example, without ICAO designators and they are not coded as routes in the GPS database
- (An airline's customised database may include such routes)

Example of a SID which is not coded in RNAV databases

EICK Cork

JEPPESEN

29 SEP 00

10-3

Eff 5 Oct

CORK, IRELAND

CORK

SID

SID

DO NOT USE FOR NAVIGATION

TRANS LEVEL: BY ATC
TRANS ALT: 5000'

OMNIDIRECTIONAL DEPARTURES

(RWYS 07, 17, 25, 35)

CAT A & B

NON JET

MAX IAS 250 KT below FL100.
Departures are also minimum noise routings
and require a minimum climb gradient of
273' per nm (4.5%).

Gnd speed-Kts	75	100	150	200	250	300
273' per nm	342	456	684	911	1139	1367

If unable to comply inform ATC as soon as possible.
CAT A & B aircraft may be assigned an omnidirectional departure
appropriate to CAT C & D aircraft at the discretion of ATC.

RWY	ROUTING
07	Climb on 069° track to 1000', then depart as directed by ATC.
17	Climb on 167° track to 1000', then depart as directed by ATC.
25	Climb on 249° track to 1000', then depart as directed by ATC.
35	Climb on 347° track to 1000', then depart as directed by ATC.

OMNIDIRECTIONAL DEPARTURES

(RWYS 17, 35)

CAT C & D

JET

MAX IAS 250 KT below FL100.
Departures are also minimum noise routings
and require a minimum climb gradient of
553' per nm (9.1%).

Gnd speed-Kts	75	100	150	200	250	300
553' per nm	691	922	1382	1843	2304	2765

If unable to comply inform ATC as soon as possible.

RWY	ROUTING
17	Climb on 167° track to 2000', then depart as directed by ATC.
35	Climb on 347° track to 2000', then depart as directed by ATC.

- Although this chart has a SID title, the omnidirectional departures do not have a route structure, so they are not coded as a departure procedures in the database

(illustrative example, route-based SIDs were introduced at EICK in Feb 2008)

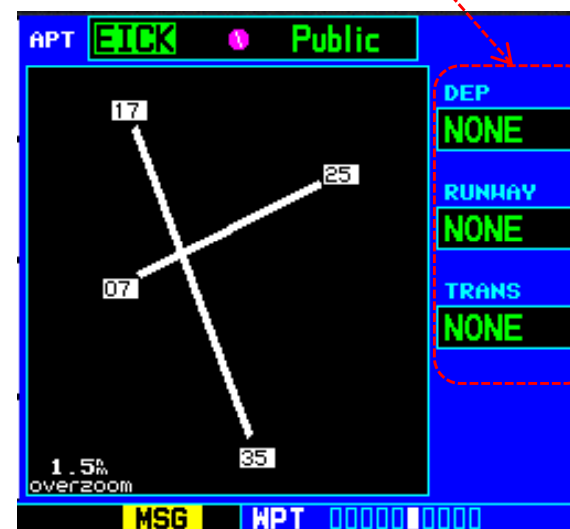

Structure of Arrival and Approach procedures

1. The ICAO model

The ICAO arrival and approach procedure model:

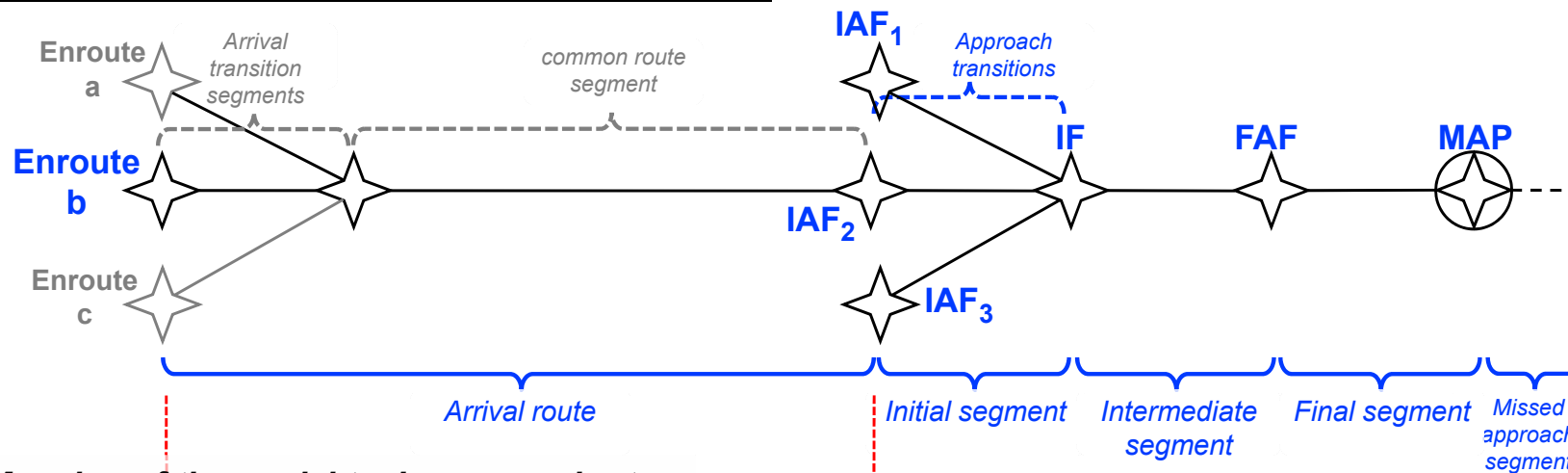

The 5 segments of an instrument procedure

Mapping of the model to Jeppesen charts:



Mapping of the chart structure to GPS database procedure records

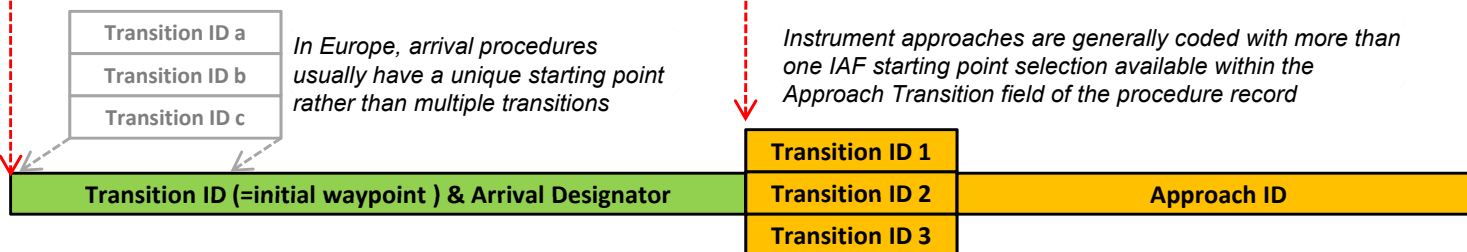

- ➔ The typical arrival structure involves STAR routes beginning at enroute waypoints and ending at the IAF and Instrument Approach procedures starting at the IAF

Structure of Arrival and Approach procedures

2. Example of conventional STAR and Approach structure

STAR chart

JERSEY, UK

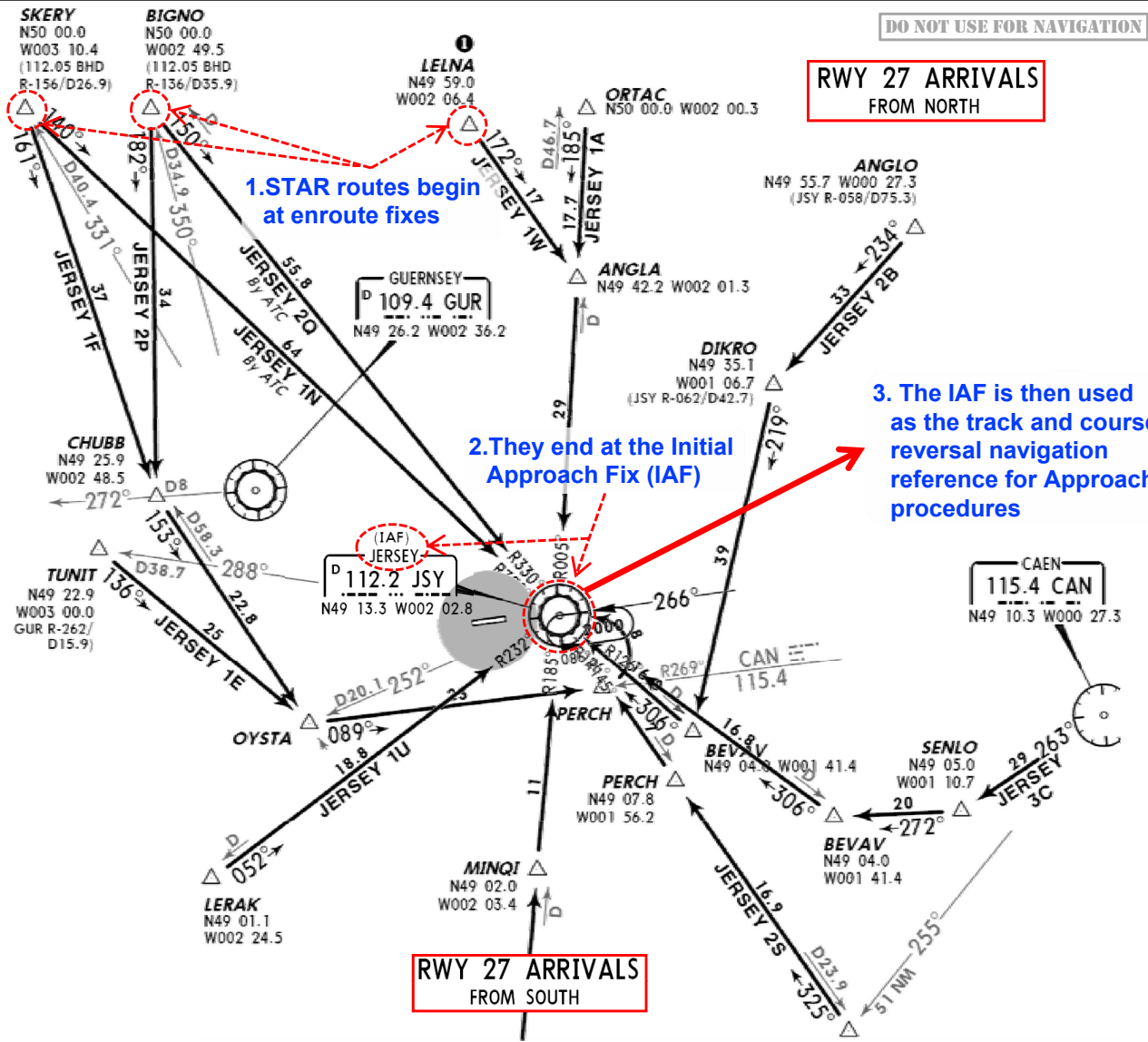

Approach chart

JERSEY, UK

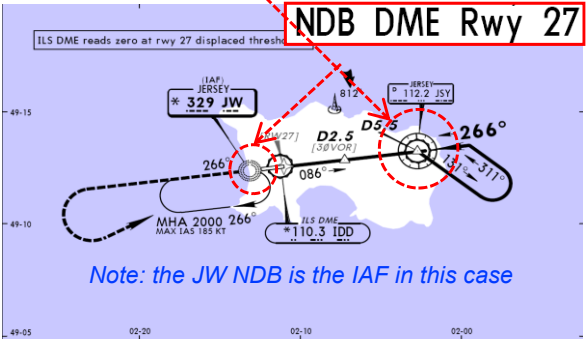
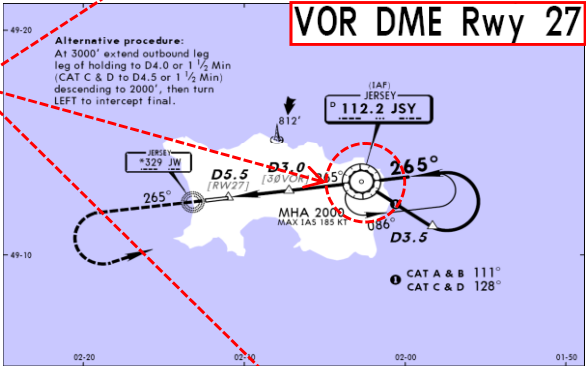
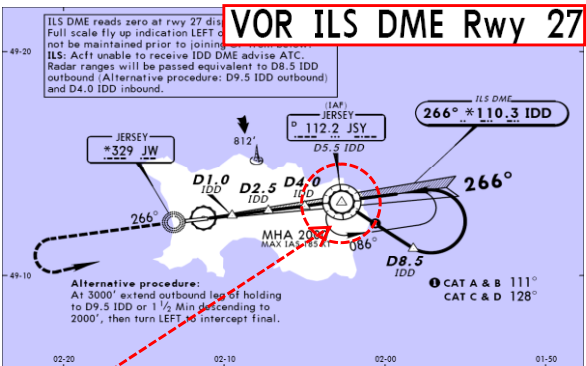

Structure of Arrival and Approach procedures

3. Examples of other structures

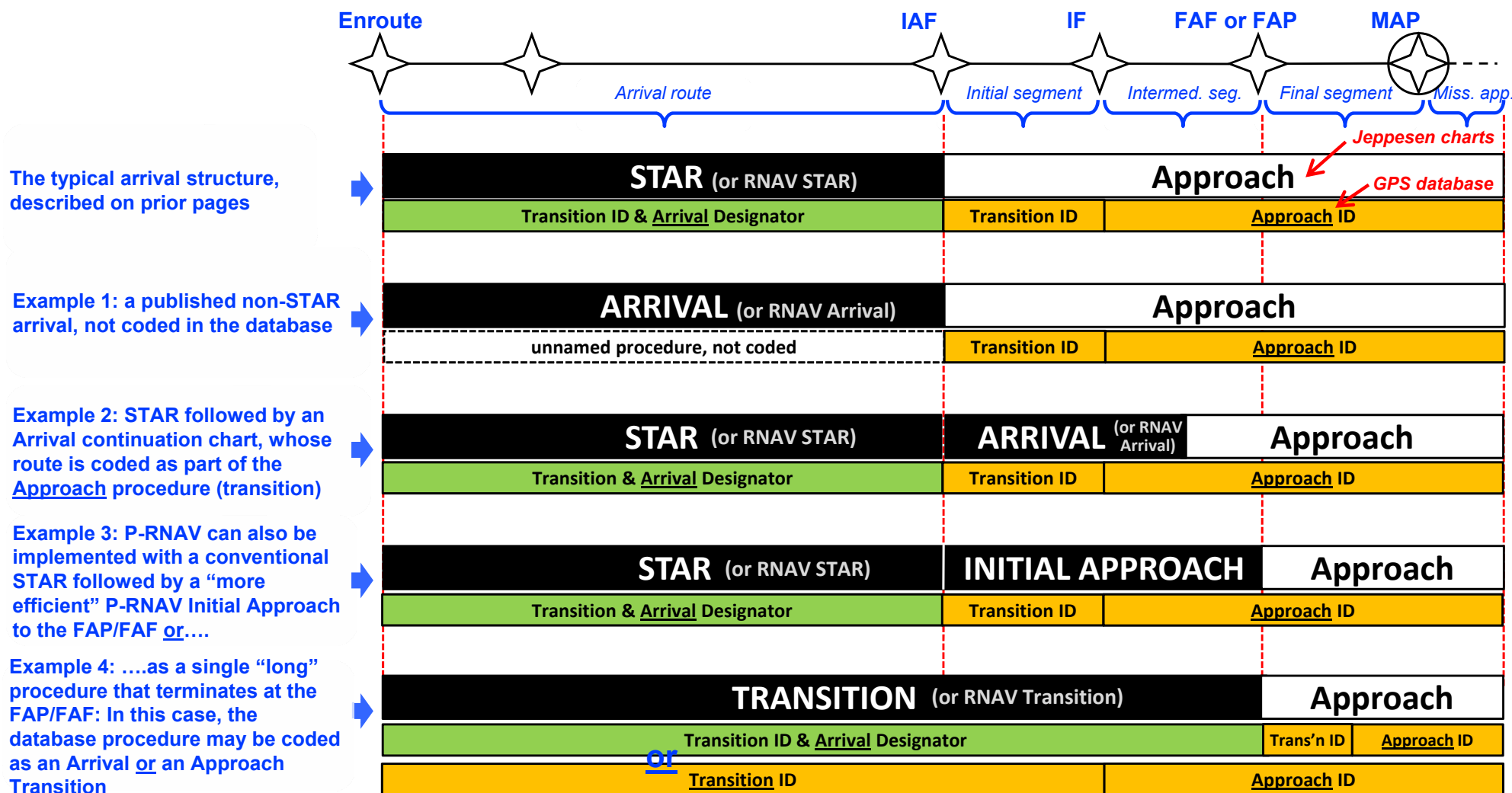

- RNAV can avoid the inefficient requirement, in many conventional procedures, for arrivals to reach the IAF, track outbound, perform a course reversal and then establish on final approach. Hence, many RNAV arrivals provide an “efficient” route terminating at the FAP/FAF

Procedure titles and names

4. Arrival procedures

Summary of Arrival procedure titles in Jeppesen charts:

	'general' IFR procedures	<u>standard</u> IFR procedures
Traditional	ARRIVAL	STAR ARRIVAL TRANSITION INITIAL APPROACH
RNAV	RNAV ARRIVAL (not used at present)	RNAV STAR RNAV ARRIVAL RNAV TRANSITION RNAV INITIAL APPROACH

- ➔ • Note that an “Arrival” chart may be a ‘general’ route (not coded in the RNAV database), or a continuation route coded within the transition selections for an approach
- The examples that follow illustrate each of the procedure types

Procedure titles and names

5. Arrival procedure designators

Example: STAR designator

This is the name used by ATC, and also the ICAO designator if a shorter version is not printed in (curved brackets)

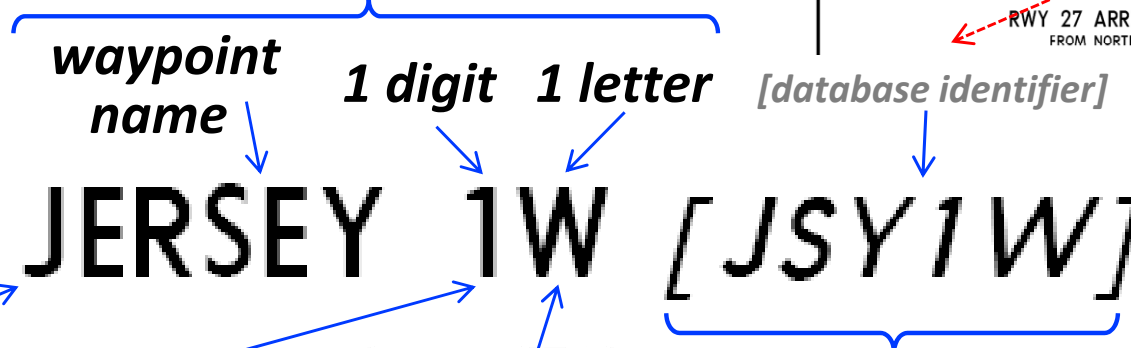

Example:

- In the UK, usually the full name of the waypoint or fix at the end of the procedure (as in this example, the Jersey VOR)
- Other than in the UK, usually the name of the waypoint or fix at the start of the procedure

Version number of the procedure, increased by 1 every time a change is made, cycling back to 1 after 9

A code letter for a specific arrival route. Important, because many different routes may share the same waypoint name. Otherwise, a route code, runway code or other ATC code.

- the database identifier is printed in [square brackets]
- If the ICAO designator is a 5LNC, it will drop the last character
- If the ICAO name is a VOR, it will use the 3 letter ident of the VOR

EGJJ/JER JERSEY		JEPPESEN 9 MAR 07 (10-2A) Eff 15 Mar		JERSEY, UK STAR
*ATIS 112.2	Apt Elev 277'	Alt Set: hPa Trans level: By ATC	Trans alt: 3000'	
JERSEY 1A [JSY1A], JERSEY 2B [JSY2B] JERSEY 1E [JSY1E], JERSEY 1F [JSY1F] JERSEY 2P [JSY2P], JERSEY 1W [JSY1W]				
JERSEY 1N, JERSEY 2Q BY ATC, NOT TO BE USED FOR FLIGHT PLANNING RWY 27 ARRIVALS FROM NORTH				

- ➔ Terminal procedure database identifiers are always in the format **aaana** or **aaaana**
- No other record uses this format. Other identifiers at the top of a “Transition” or “Initial Approach” arrival chart will denote a fix, waypoint or other kind of route name which, usually, means that the route is coded as a transition that is part of an Approach procedure record

Procedure titles and names

6. Transition and Initial Approach examples

EGLL/LHR HEATHROW **JEPPESEN** **LONDON, UK**
 14 SEP 07 (10-2F) **INITIAL APPROACH**

*D-ATIS 113.75 115.1 128.07	Apt Elev 83'	Alt Set: hPa Trans level: By ATC Trans alt: 6000' 1. Minimum holding level (Flight Level Equivalent of 7000') is above TA and will be allocated by ATC. 2. Initial approach procedures are designed for manoeuvring speeds up to 220 KT TAS and assume acft can maintain a descent gradient of approximately 320' per NM. 3. Continuous descent approach should be used whenever practicable unless otherwise instructed by ATC. Procedure design is compatible with 3° descent path from 6000'.
--------------------------------------	-----------------	---

RWYS 09L/R, 27L/R
INITIAL APPROACH PROCEDURES
 WITHOUT RADAR CONTROL
 FROM BIG TO ILS

Note that both the EGLL and EDDF examples, although coded in the database as Approach transitions, appear in the STAR section of their respective State AIPs

STAR	INITIAL APPROACH	Approach
Transition & Arrival Designator	Transn ID	Approach ID

1. No route designator...
2. but the route starts at "BIG" VOR
3. and BIG is also labelled as the IAF, and various EGLL STARS terminate at BIG

4. hence it is an Approach procedure record
5. with "BIG" available as the Approach transition

EDDF/FRA FRANKFURT/MAIN, GERMANY **JEPPESEN** **FRANKFURT/MAIN, GERMANY**
 17 AUG 07 (10-2D) Eff 30 Aug **RNAV TRANSITION**

*ATIS 118.02 114.2	Apt Elev 364'	Alt Set: hPa (IN on request) Trans level: By ATC Trans alt: 5000' 1. On downwind transition expect vectors to final. 2. Speed restrictions on Transition (even without profile) are always mandatory, unless cancelled by ATC.
--------------------------	------------------	--

PSA 07
RWYS 07L/R RNAV TRANSITION
 GPS- OR FMS-EQUIPPED AIRCRAFT
 USE OF RNAV TRANSITION ONLY WHEN CLEARED BY ATC

DO NOT USE FOR NAVIGATION

RNAV TRANSITION	Approach
Transition ID	Approach ID

1. The route name is not a procedure identifier
- The route starts at "PSA" VOR and is for Runway 07 approaches, thus the route name used is "PSA 07"

2. hence it is an Approach procedure record
3. with "PSA" available as the Approach transition

EGLL/EMA EAST MIDLANDS **JEPPESEN** **EAST MIDLANDS, UK**
 15 FEB 08 (10-2E) **RNAV TRANSITION**

ATIS 128.22	Apt Elev 306'	Alt Set: hPa Trans level: By ATC Trans alt: 4000' Participating aircraft will be cleared initially via appropriate conventional STAR prior to clearance for RNAV initial approach.
----------------	------------------	---

NEMAX 1A [NEMA1A]
P-RNAV INITIAL APPROACH PROCEDURE
 TO ILS RWY 27 FINAL APPROACH
 ONLY AVAILABLE TO APPROVED PARTICIPATING ACFT WITH RNAV SYSTEMS FUNCTIONALITY EQUAL TO OR BETTER THAN THAT SPECIFIED IN JAA TGL-10 FOR P-RNAV OPERATIONS IN TERMINAL AIRSPACE

RNAV TRANSITION	Approach
Transition ID & Arrival Designator	Approach ID

1. The chart has an ICAO procedure designator (and a database procedure identifier)

2. hence it is an Arrival procedure record
3. with "NEMA1A" as the identifier

4. The route starts at "VELAG", which is the only available transition in the database

Example of a 'general' Arrival

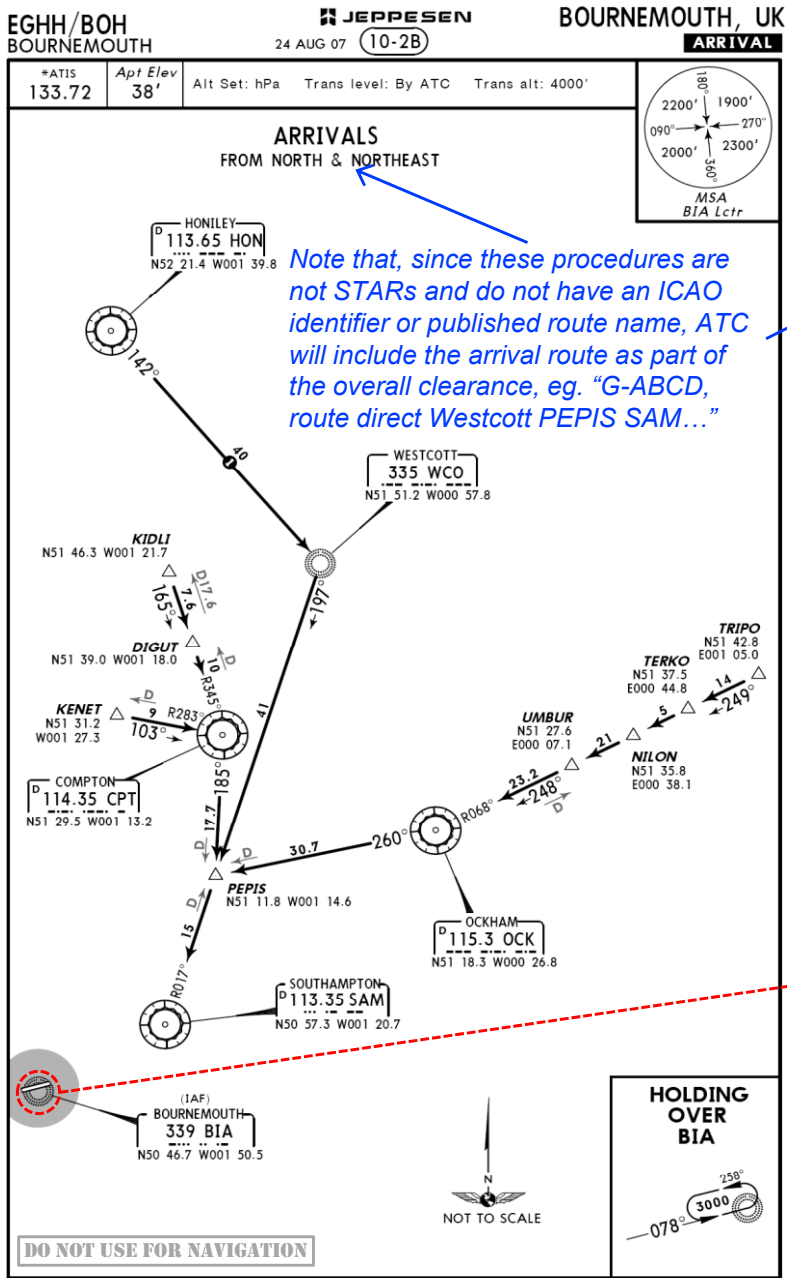

ARRIVAL ARRIVALS

FROM NORTH & NORTHEAST

The Arrival record selection includes all of the published STARs for EGHH, which are coded in the normal way, but not any routes called "North" or "Northeast" - they are not coded in the database

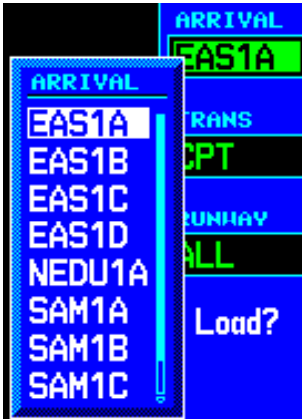

Garmin GNS530W procedure selection pages

The approach procedures at EGHH have only one transition available, the "BIA" NDB on the airport, plus Vectors to Final. In this example, at the end of the arrival route, an aircraft would be cleared to the BIA for a procedural approach or be given radar vectors to the localiser



Example of a conventional STAR

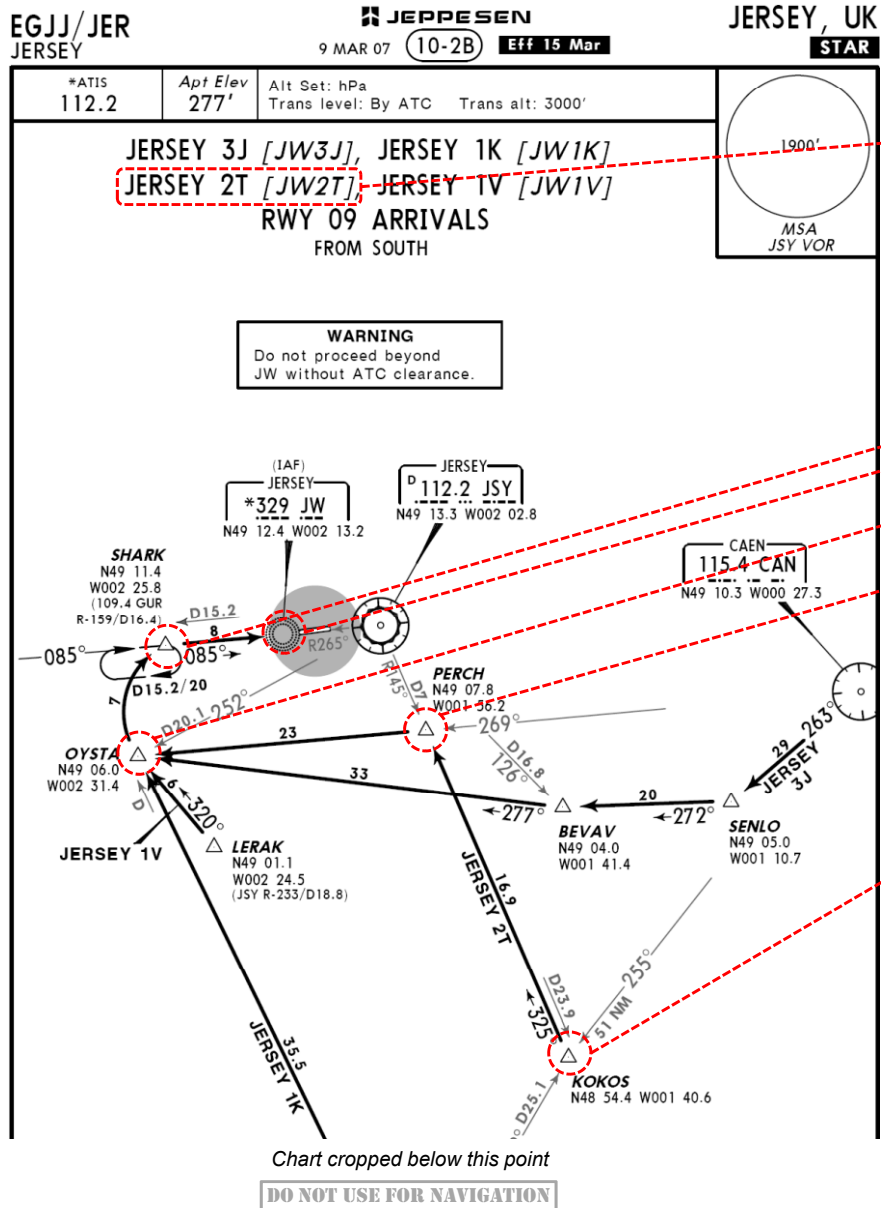

STAR JERSEY 2T [JW2T]

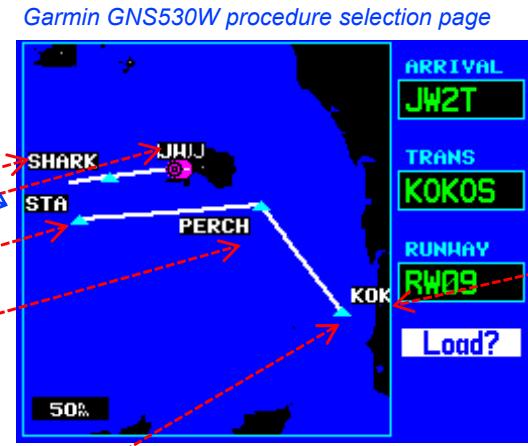

OYSTA
(name cropped on screen edge)

KOKOS
(name cropped on screen edge)

Arrival JW2T

KOKOS		
PERCH	325° _H	16.9 _M
OYSTA	268° _H	23.2 _M
SHARK	085° _H	5.0 _M
JW	086° _H	8.3 _M

5LNCs

NDB ident

Garmin GNS530W flight plan waypoint list

Example of an RNAV STAR to the IAF

(but see next page)

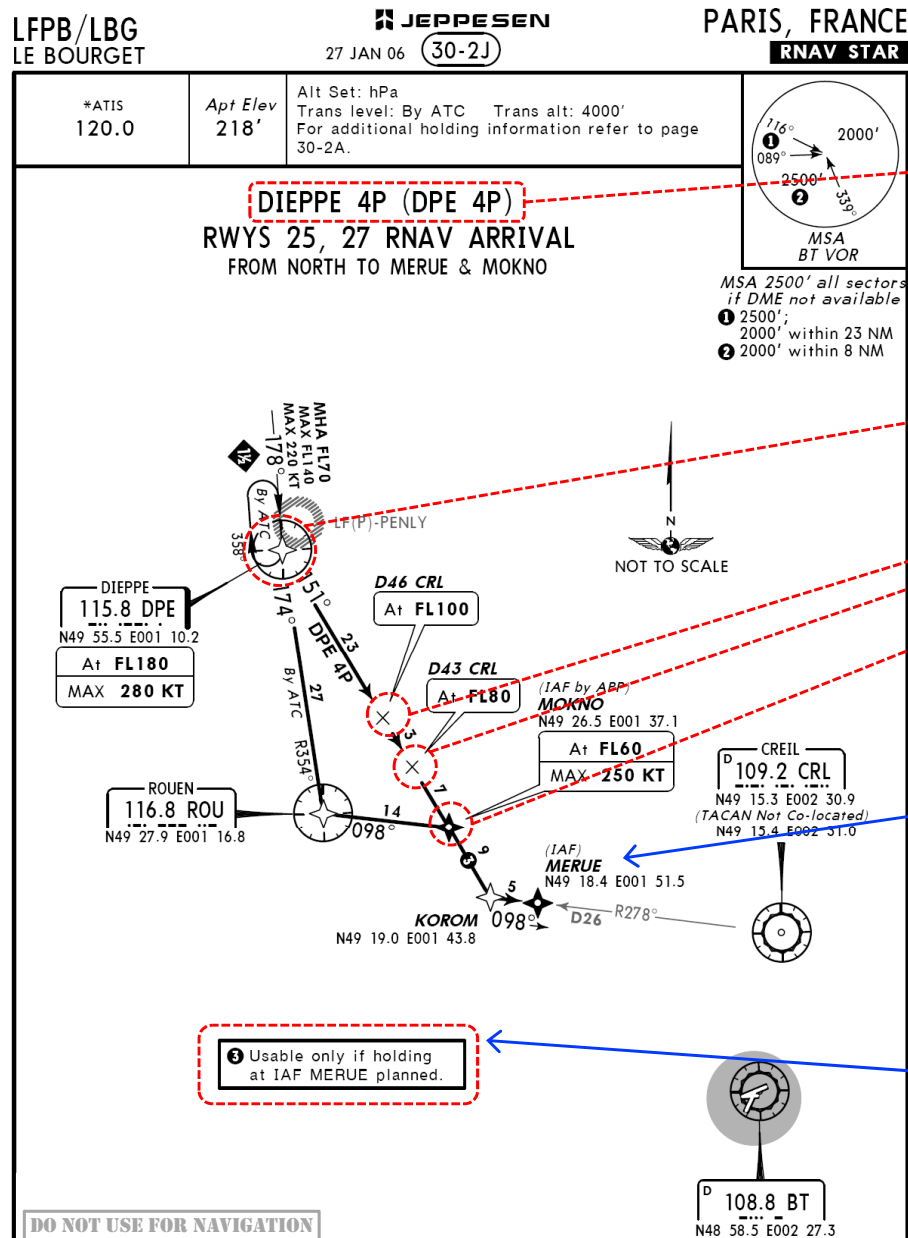

RNAV STAR

DIEPPE 4P (DPE 4P)

STARs are published RNAV and are available in B-RNAV

Is this a P-RNAV or B-RNAV route? Page 30-2 of the LFPB charts has overall information on arrivals and includes the comment

Garmin GNS530W procedure selection page



The runway field is "All" if the same route is used for more than one runway. In this case, the procedure is for 2 of the 6 runways at LFPB

Garmin GNS530W flight plan waypoint list

Arrival DPE4P		
DPE		
CRL46	150°M	22.5 _m
CRL43	148°M	3.6 _m
MOKNO	151°M	7.8 _m

The charted procedure seems to end at MERUE but in the GPS database DPE4P ends at MOKNO?

Note the comment that the route segment to MERUE is only if holding there. (The AIP chart is clearer and shows a dotted line for the MOKNO to MERUE segment)

In fact, LFPB is an example of an airport that uses an "RNAV STAR" chart followed by an "RNAV Arrival" continuation chart - see next page

This RNAV STAR is followed by an RNAV Arrival 'continuation' chart from the IAF, which is coded as an Approach transition

RNAV STAR → RNAV ARRIVAL

DIEPPE 4P (DPE 4P)

RWYS 07, 25, 27
RNAV ARRIVAL PROCEDURES
FROM MERUE & MOKNO

Selecting (for example) the ILS27 database procedure results in a pop-up list of available transitions that includes MONKO; this is the route on the RNAV ARRIVAL chart

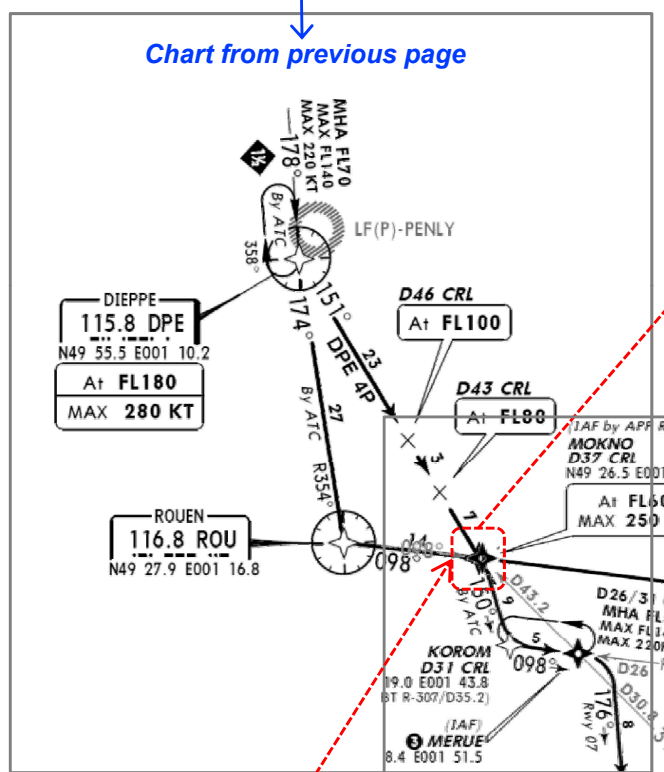

LFPB/LBG LE BOURGET		PARIS, FRANCE	
RNAV ARRIVAL			
*ATIS	120.0	DE GAULLE Approach	Apt Elev 218'
		121.15 125.82	Alt Set: hPa
		119.85 126.42	Trans level: By ATC
		118.15 136.27	Trans alt: 4000'



Arrival chart (this is an Initial Approach chart in the French AIP)

The DPE4P procedure is for Runways 25 & 27. The Arrival chart shows how the STAR ends at MONKO and the route continues east from there. The Southbound arrival from MEURE is a continuation of other STARs (DPE4E, DPE4H) for Runway 07.

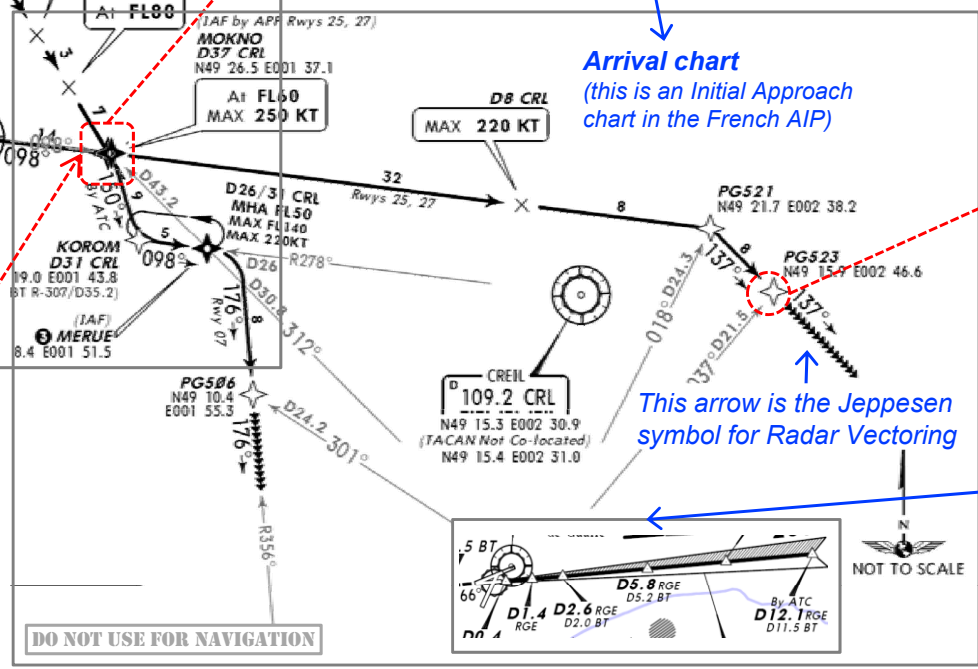

RNAV ARRIVAL
ILS27

Approach ILS 27			
MOKNO IA			
D338H	097° _H	32.1 _M	
PG521	098° _H	8.0 _M	
PG523	137° _H	8.0 _M	
man seq	137° _H	0.0 _M	
CI27	266° _H	19.0 _M	
FI27 FA	267° _H	6.1 _M	
RW27 HA	266° _H	2.4 _M	

The "man seq" leg name shows that waypoint sequencing is suspended for the Radar Vectoring segment, it is re-engaged in the Garmin 430/530 by pressing the OBS key

ILS DME Rwy 27

LFPB/LBG LE BOURGET		PARIS, FRANCE	
ILS DME Rwy 27			
*ATIS	120.0	*LE BOURGET Tower	118.92
		*Ground	121.9
LOC	Final	GS	ILS
RGE	Apch Crs	D2.6 RGE	DA(H)
110.55	266°	980' (814')	366' (200')
Apt Elev 218'			
RWY 166'			
Missed Approach - See below			
Alt Set: hPa	Rwy Elev: 6 hPa	Trans level: By ATC	Trans alt: 4000'

DO NOT USE FOR NAVIGATION

Example of an RNAV transition to the final approach (coded in the database as an Arrival Procedure)

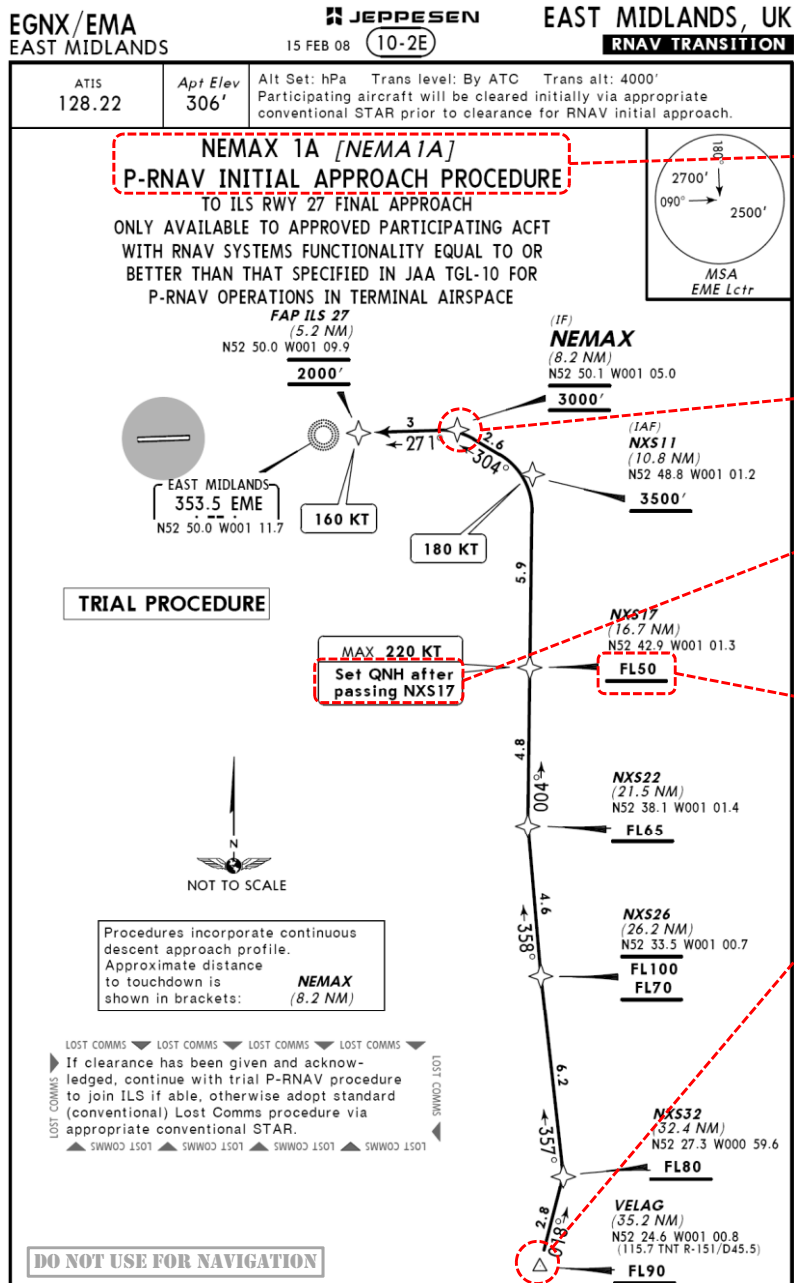

RNAV TRANSITION

NEMAX 1A [NEMA1A] P-RNAV INITIAL APPROACH PROCEDURE

Garmin GNS530W procedure selection page

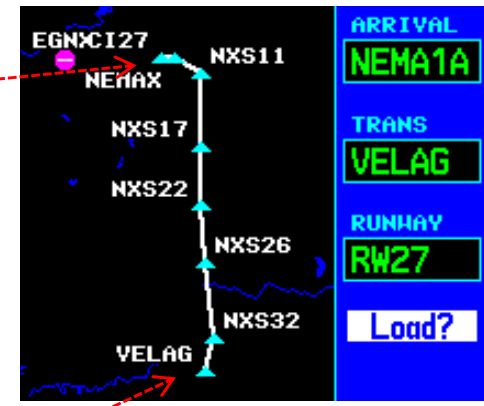

Note QNH setting is based on LNAV reference

Set QNH after passing NXS17

Note various level, altitude and speed limits at Waypoints

FL50

Garmin GNS530W flight plan waypoint list

Arrival NEMA1A		
VELAG		
NXS32	017° _M	2.8 _{nm}
NXS26	356° _M	6.2 _{nm}
NXS22	357° _M	4.6 _{nm}
NXS17	003° _M	4.8 _{nm}
NXS11	003° _M	5.9 _{nm}
NEMAX	303° _M	2.7 _{nm}
CI27	271° _M	1.1 _{nm}

(IAF) 5LNC

5LNC

Airport CNF

These are tactical RNAV waypoints (not CNFs) – using the “aannn or aaann” convention, in this case “NX” are the last two letters of the EGNX identifier, “S” indicates a Southerly arrival, and the two digits are the along-track distance to touchdown in nm

Example of an RNAV transition to the final approach (coded in the database as an Approach Transition)

EDDF/FRA
FRANKFURT/MAIN

JEPPESEN FRANKFURT/MAIN, GERMANY
17 AUG 07 (10-2E) Eff 30 Aug RNAV TRANSITION

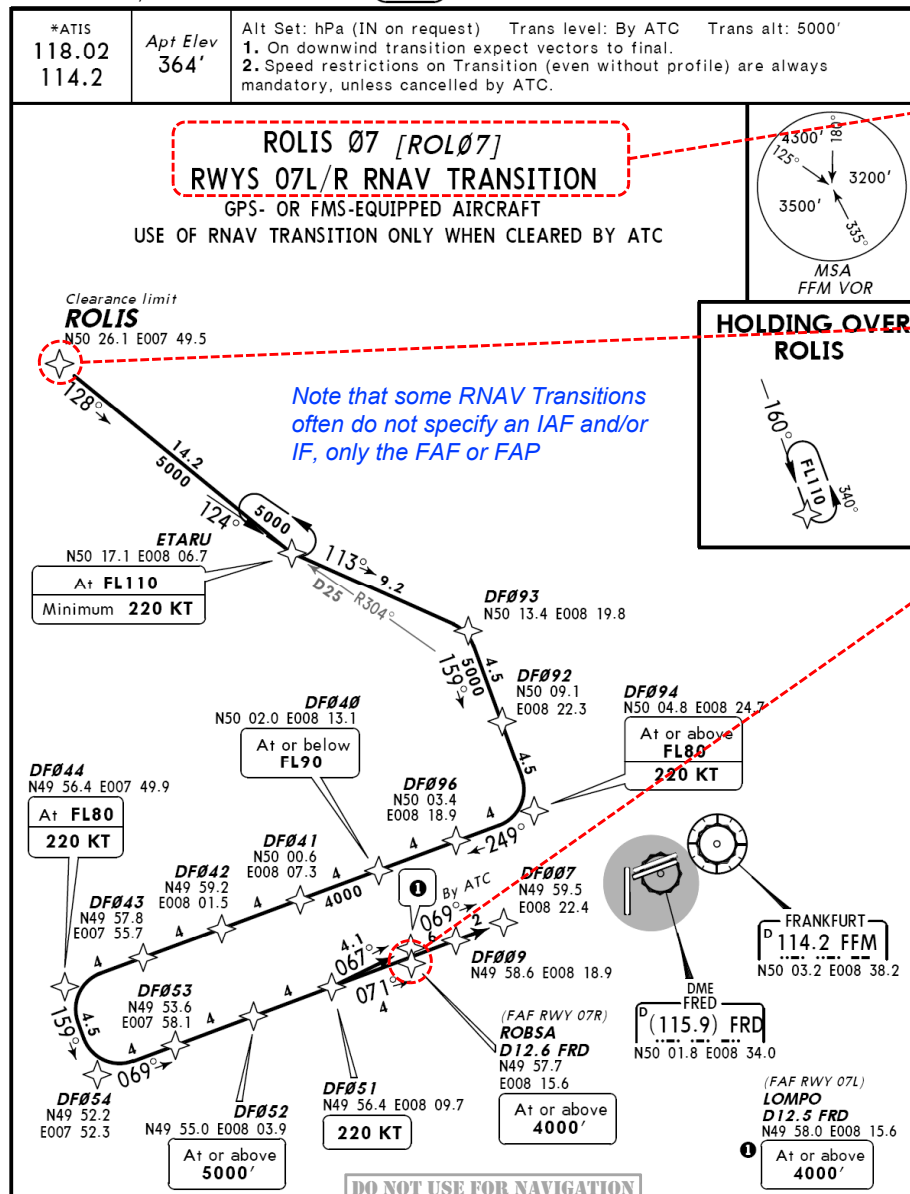

RNAV TRANSITION

ROLIS 07 [ROL07] RWYS 07L/R RNAV TRANSITION

Garmin GNS530W procedure selection page

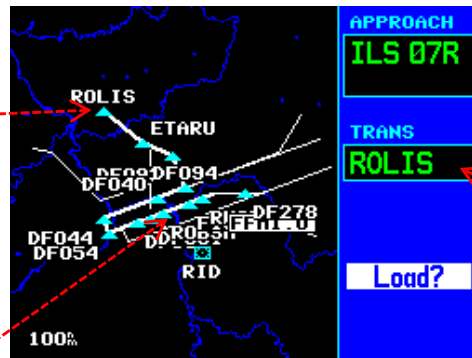

APPROACH
ILS 07R

TRANS
ROLIS

Load?

- The transition route name on the chart is the name of the waypoint at the start of the procedure plus the runway number (ROLIS 07) and the database identifier in square brackets is an abbreviated version of this (ROL07).
- GPS databases do not use this convention. All transitions are waypoint identifiers only (ROLIS in this example)
- The GPS procedure must be cross-checked against the paper chart to ensure the ROLIS GPS transition route is the same as the charted ROLIS 07 route

Garmin GNS530W flight plan waypoint list

Approach ILS 07R		
ROLIS		
ETARU	128° _H	14.2 _N _M
DF093	113° _H	9.2 _N _M
DF094	159° _H	9.1 _N _M
DF040	249° _H	8.0 _N _M
DF044	248° _H	16.0 _N _M
DF054	159° _H	4.5 _N _M
DF052	068° _H	8.0 _N _M
DF051	068° _H	4.0 _N _M
ROBSA	070° _H	4.0 _N _M
FI07R _{FA}	068° _H	7.5 _N _M
RW07R _{HA}	069° _H	3.9 _N _M

These tactical RNAV waypoints use the "aann" convention, in this case "DF" are the last two letters of the EDDF identifier. The last 3 digits are arbitrary and unique within the Frankfurt TMA

5LNCs
5LNC
Airport CNFs

Example of RNAV STAR arrival structure to the IAF (compare with the "long" RNAV transitions on the two prior pages)

LEBL/BCN BARCELONA

Transition ID
TRANS
VECTORS
CLE IA
LESBA IA
RULOS IA
SLL IA

ILS Rwy 25R
Approach ID

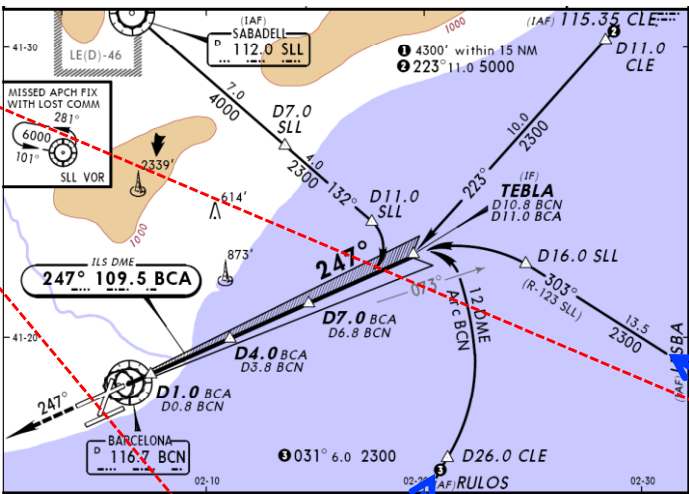

RNAV STAR
Transition ID & Arrival Designator
BISBA TWO YANKEE (BISBA 2Y) [BISB2Y]
RWYS 25L/R RNAV ARRIVAL
RNAV (DME/DME)
P-RNAV APPROVAL REQUIRED



Note the long list of arrivals available at LEBL, with many very similar identifiers

RNAV STAR
Transition ID & Arrival Designator
CASPE TWO YANKEE (CASPE 2Y) [CASP2Y]
MATEX ONE YANKEE (MATEX 1Y) [MATE1Y]
RWYS 25L/R RNAV ARRIVALS
RNAV (DME/DME)
P-RNAV APPROVAL REQUIRED
FROM SOUTHWEST

ARRIVAL
CASP2S
TRANS
CASPE
RUNWAY
ALL

ARRIVAL
MATE1Y
TRANS
MATEX
RUNWAY
RW25B

Note the somewhat inconsistent coding of the associated runway, all these procedures are for 25L or 25R, the field is "25B" for both in some arrivals and "ALL" in others.

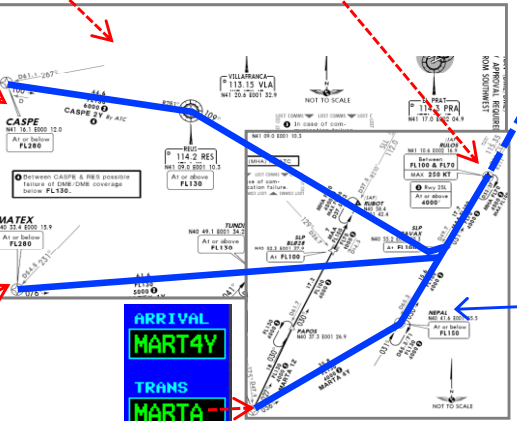

RNAV STAR
Transition ID & Arrival Designator
MARTA FOUR YANKEE (MARTA 4Y) [MART4Y]
RWYS 25L/R RNAV ARRIVAL
RNAV (DME/DME)
P-RNAV APPROVAL REQUIRED

ARRIVAL
MART4Y
TRANS
MARTA
RUNWAY
RW25B

Arrival Designator

ARRIVAL	ARRIVAL
ALBE1S	MART1Z
ALBE1T	MART2S
BISB1S	MART2T
BISB1T	MART4Y
BISB2V	MATE1S
BISB2Y	MATE1T
CASP1U	MATE1Y
CASP2S	MATE1Z
CASP2Y	NEPA2V
CASP4T	OSTU1U
GRAU1U	OSTU1V
GRAU3S	PUMA3S
GRAU4T	PUMA3T
LOBA1U	VERS1S
LOBA3S	VERS1V
LOBA3T	VERS1Z

Altitude and Speed restriction coding in ARINC 424 database procedures

- ARINC 424 does provide for the encoding of altitude and speed restrictions published in IFR procedure charts and this feature is implemented in modern Flight Management Systems
- Speed and Altitude restrictions are part of path-terminator records, or the waypoint associated with a path-terminator.
- This data is generally not implemented in panel-mount GPS units, or the integrated 'glass cockpits' currently fitted to piston aircraft, except for the altitude terminator of the CA, VA or FA leg types (course, heading and track to altitude respectively)
- A brief description of the coding is provided below, however, any further detail is beyond the scope of this course

Altitude Restrictions

- Altitude restrictions are usually applied at waypoints, although ARINC 424 provides a number of different ways they can be coded.
- The altitude field will designate whether a waypoint should be crossed "at", "at or above" or "at or below" or "between" specified altitudes or flight levels.
- **If a published departure requires a turn greater than 15 degrees from the runway heading after take-off, without an altitude specified before the turn, the GPS database will generally include a CA, VA, or FA on the runway heading to an altitude of 400 feet (or as specified by source) as the first leg of the departure**
- Conditional altitudes (eg. turn at 2000' or 4DME whichever is later) are treated in different way by different FMS types.
- Altitude restrictions that only apply during specific times are not coded

Speed Restrictions

- In departures, a speed limit is applied backwards from the terminator of the leg on which the limit is encoded to the start of the procedure, or to the first prior speed limit
- In arrivals, a speed limit is applied forwards from the speed limit point to the end of arrival, unless a subsequent speed limit is encoded
- Speed restrictions that only apply during specific times are not coded



1. “Database Overlays”



2. “Published Overlays”



3. RNAV Approaches

	1. “Database Overlays”	2. “Published Overlays”	3. RNAV Approaches
Precision Approaches	<ul style="list-style-type: none"> All ILS approaches are coded as database overlays 	<ul style="list-style-type: none"> There are currently no RNAV precision approaches in Europe 	
Non-Precision Approaches (NPA)	<ul style="list-style-type: none"> All AIS-published route-based NPAs are coded as database overlays (within the coverage limits of the database) Radar approaches are not coded 	<ul style="list-style-type: none"> A small number of non-precision approach procedures in Europe are published overlays, with a title that includes an RNAV method of navigation (eg. “VOR DME or GPS Rwy 27”) 	<ul style="list-style-type: none"> Non-precision GPS approaches are increasingly common in Europe. A variety of names are used (RNAV, GNSS, GPS) Airport CNFs are usually published on the paper charts

- ➔ This section will review how conventional and RNAV approaches are coded and presented in GPS databases, and the formats used for approach procedure names and database identifiers
- The examples illustrate the RNAV issues relevant to this section, but not every variety of procedure is detailed
- Note that important topics not specific to RNAV (eg. approach minima, circle-to-land procedures, obstacle clearance and MSAs) are not considered
- The detailed description of Database Overlays is not an implicit endorsement of using GPS as primary guidance for conventional approaches: quite the opposite, it illustrates complexities and discrepancies which reinforce why approaches must be flown using the primary navigation method described on the paper chart
- GPS units, other than the modern WAAS-approved models, do not provide guidance for many of the path-terminators used in database approach overlays. A pilot relying on such GPS guidance may find that it is suspended and no “magenta line” and CDI indication (or autopilot LNAV commands) are present during critical segments of approach or missed approach procedures

Procedure titles and names

5. Jeppesen chart index number convention



Jeppesen chart index example

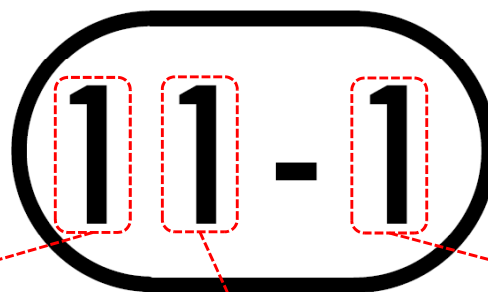

1st digit: arbitrary Airport number

- Usually 1, but higher numbers are used to distinguish airports under the same city name
- For example, for LONDON UK, 1 is used for Heathrow, 2 for Gatwick, 3 for Stansted, 4 for London City, etc

2nd digit: Chart Type

- 0 – terminal procedure and airport charts
- 1 – ILS, LOC, LDA (also MLS, SDF, KRM)
- 2 – GPS (sole use of GPS, not “or GPS”)
- 3 – VOR
- 4 – TACAN
- 5 – Reserved, not currently used
- 6 – NDB
- 7 – DF (radio direction finding, QDM approach)
- 8 – Radar approaches (eg. SRA, PAR)
- 9 – Vicinity chart, Visual chart

3rd digit: sequence number for charts of the same type

- For example, in the illustration above, further ILS approach charts at EGHH would have a chart index of 11-2, 11-3 etc
- Note that the “0” chart type can have many pages of SIDs and STARs, hence the sequence number may be in the format 1digit+1letter or 1digit+1letter+1digit if required

for example: **10-3Q7**

Note on AIP chart naming conventions

There is not a consistent standard for AIP chart names. For example, the UK uses 2:Aerodrome, 4:Airspace, 5:MVA, 6:SID, 7:STAR, 8:Approach. In Germany, it is 2:Aerodrome, 3: STAR, 4:Approach, 5:SID. Other states don't use a numbered convention, but titles such as IAC, SID, STAR, VAC and sort the charts in that order

Procedure titles and names

6. Approach chart name conventions

- Until a few years ago, the ICAO standard for approaches was that the procedure title should include the nav aids to be used. This convention led to a significant amount of variation from state to state, and the requirements for navigation equipment were not always explicit.
- The present convention is more highly standardised, but many current European charts still use the former ICAO standards
- The current convention is summarised in the form of the 7 rules below:

Rule 1: Basic name	Rule 2: “or”	Rule 3: Secondary navaid	Rule 4: Chart notes
<ul style="list-style-type: none"> • The chart title is the primary navaid for the procedure plus “Rwy” and the runway identifier • eg. ILS Rwy 27, NDB Rwy 09L • “ILS” means that <u>both</u> the localiser and glideslope are required • “LOC” is used instead of “LLZ” as the Localiser abbreviation 	<ul style="list-style-type: none"> • If more than one type of procedure is published on the same page, then “or” is used • eg. ILS or LOC Rwy 27 VOR or NDB Rwy 09L 	<ul style="list-style-type: none"> • If nav aids other than the primary one are required, this is noted on the chart rather than included in the title; eg. “ILS Rwy 27” with a <u>chart note</u> if DME is required • <u>Some countries continue to include DME in the chart title</u> 	<ul style="list-style-type: none"> • The chart notes may include other important requirements eg. other nav aids, communications equipment, crew training or authorisations, ATC radar availability etc
Rule 5: Multiple procedures	Rule 6: Offset final approach	Rule 7: RNAV	
<ul style="list-style-type: none"> • When there are multiple procedure charts of the same type for the same runway, their titles are differentiated by adding a single letter, (starting at “Z” and sequenced in reverse alphabetical order) after the navaid type and before “Rwy” • The multiple procedures may relate to different final approach transition routes published on different pages, requirements for navigation equipment, charts for different aircraft categories or variations on an approach design for other operational reasons • eg. ‘VOR Z Rwy 09L’ followed by ‘VOR Y Rwy 09L’ 	<ul style="list-style-type: none"> • When a procedure does not meet straight-in landing minima, the navaid is followed by “A”. Subsequent such procedures at the same airport will use “B”, “C” etc • eg. NDB A Rwy 09 	<ul style="list-style-type: none"> • The current standard is to use the more generic ‘GNSS’ instead of GPS, but GPS still appears on many current charts • RNAV approaches may specify the equipment type to be used or an RNP value required • eg. GNSS Rwy 07, RNAV (GNSS) Rwy 07, RNAV Rwy 07 	

Procedure titles and names

7. Example of the “Z, Y, X...” approach procedure title convention

LESO/EAS SAN SEBASTIAN 27 OCT 06 (13-1) CAT A, B & C **VOR Z** Rwy 04

*SAN SEBASTIAN Approach 119.85		*SAN SEBASTIAN Tower 119.85		*Ground 121.7
VOR SSN 117.9	Final Apch Crs 033°	Minimum Alt D7.0 3500' (3484')	MDA(H) Refer to Minimums	Apt Elev 16'

MISSED APCH: Climb on R-021 to D2.0. Turn LEFT on heading 319° to intercept and follow 5 DME Arc (counterclockwise), then follow R-213 direct to MENDI to enter holding at 7000'. 5% missed apch climb gradient recommended.

Alt Set: hPa Apt Elev: 1 hPa Trans level: By ATC Trans alt: 6000' MSA SSN VOR

'DME required' chart note

DO NOT USE FOR NAVIGATION

- Example where there are two VOR approach charts to Runway 04, hence the procedure titles 'VOR X' and 'VOR Y'
- The difference between them is that the 'VOR Y' approach has a later missed approach point (1d inbound from SSN, rather than at SSN) and correspondingly lower minima
- Only the 'Z' variant is coded in the GPS database, and the procedure identifier does not include the 'Z' character

APPROACH VOR/DME 04 VOR/DME 22	TRANS VECTORS CHATO IFA MENDI IFA PETAS IFA SSN IFA CEGAM
--------------------------------------	---

The Garmin 530 database has 2 approach selections available for LESO. Note that the NDB procedure is "CAT A&B" only and thus not coded in the database

MENDI IFA		
D227Q	213°M	4.0 ^N _M
D213P	033°M	1.0 ^N _M
MENDI	033°M	4.0 ^N _M
FD04 FA	033°M	5.0 ^N _M
SSN MA	033°M	7.0 ^N _M

The VOR/DME 04 procedure has several transition (starting) waypoints available, as per the main chart and the small 'Arrival Routes' inset, but not a "Z" or "Y" selection

The coded version of the procedure has the MAP at SSN, not 1d inbound from it as in the 'Y' variant. (the small pink letters 'IA', 'FA' and 'MA' denote the IAF, FAF and MAP respectively. Note that the missed approach waypoints are not shown above)

LESO/EAS SAN SEBASTIAN 27 OCT 06 (13-2) CAT A, B & C **VOR Y** Rwy 04

*SAN SEBASTIAN Approach 119.85		*SAN SEBASTIAN Tower 119.85		*Ground 121.7
VOR SSN 117.9	Final Apch Crs 033°	Minimum Alt D7.0 3500' (3484')	MDA(H) Refer to Minimums	Apt Elev 16'

MISSED APCH: Climbing turn LEFT to follow R-021 until D2.0. Turn LEFT on heading 319° to intercept and follow 5 DME Arc (counterclockwise), then follow R-213 direct to MENDI to enter holding at 7000'. 5% missed apch climb gradient recommended.

Alt Set: hPa Apt Elev: 1 hPa Trans level: By ATC Trans alt: 6000' MSA SSN VOR

DME required

- In this example, there is only a very small difference between the "Z" and "Y" procedure, but some alternatives of this kind may have wholly different routes. In either case, an ARINC database includes only one procedure of a given type (eg. VOR) per runway and does not store the "Z", "Y", "X" procedures as individual records: there is not always a systematic mapping between paper charts and database procedure selections
- It is doubly important to cross-check the database with the procedure chart in such cases

Example of an NDB approach

EGHH/BOH **JEPPESEN** BOURNEMOUTH, UK
 BOURNEMOUTH NDB DME Rwy 26

Note: title with secondary navaid (DME) included. This convention is often used in Europe instead of the alternative of noting the DME requirement in the chart text

Garmin GNS530W procedure selection page

*ATIS 133.72	*BOURNEMOUTH Approach(R) 119.47	*BOURNEMOUTH Tower 125.6	*Ground 121.7
Lctr BIA 339	Final Apch Crs 255°	With DME Procedure Alt D4.5 1540' (1509')	With DME MDA(H) 460' (429')
	W/o DME Minimum Alt No FAF	W/o DME MDA(H) 660' (629')	Apt Elev 38'
			RWY 31'

MISSED APCH: Climb STRAIGHT AHEAD to D4.0 (W/o DME : 2000'), then turn LEFT to return to Lctr at 3000', or as directed.

Alt Set: hPa Rwy Elev: 1 hPa Trans level: By ATC Trans alt: 4000'

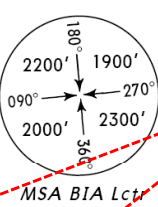

Note that the paper chart depicts distances from the DME, which reads zero at the 26 threshold. The database overlay uses along-track distance between waypoints. Hence "D7.5" on the chart becomes "D8.2" in the database, because its preceding waypoint, the BIA NDB, is 0.7nm SSW of the 26 threshold



Garmin GNS530W flight plan waypoint list

Approach NDB 26		
BIA	IA	
D8.2	055° _H	8.2 _{nm}
FN26	FA 255° _H	3.0 _{nm}
20DM2	254° _H	2.5 _{nm}
RW26	HA 257° _H	2.0 _{nm}
BIA	246° _H	0.7 _{nm}
2000'	254° _H	3.1 _{nm}
BIA		

This chart has CNF identifiers printed in faint grey [square brackets] under the DME fix names and a CNF waypoint for the 26 threshold called 'RW26'. These identifiers are used in the database procedure record

The database also uses 'RW26' as the missed approach point, rather than BIA; this is the normal convention if the charted MAP is after the runway threshold.

On the missed approach procedure, the distance to the D4.0 fix (called '2000ft' in the database to recognise the non-DME turning condition) is 3.1nm, again because of the displacement of the BIA from the DME

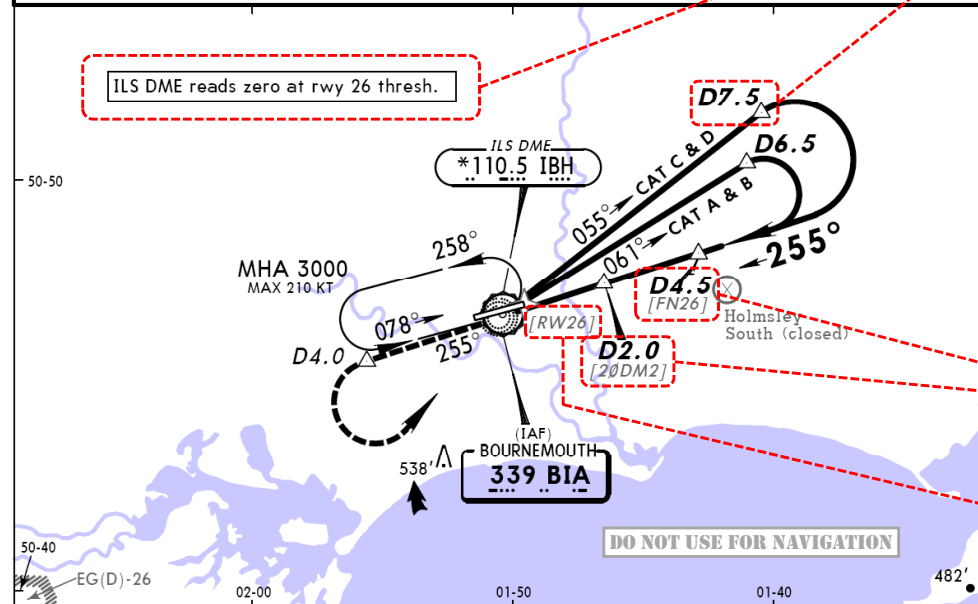

IBH DME	1.0	2.0	3.0	4.0
ALTITUDE	410'	730'	1050'	1370'

Lctr	3000'	055°	CAT C & D	CAT A & B: D6.5	W/o DME:
		061°	CAT A & B	CAT C & D: D7.5	Start
					turn at
					CAT A & B:
					3 Min
					CAT C & D:
					2 1/2 Min

[TCH 50']	[RW26]	D2.0 [20DM2]	730'	[3.06°]	255°	W/o DME	1540'
						MDA	580'
							2.5
							D4.5 [FN26]

Example of a VOR approach

EGJJ/JER
JERSEY

JEPPESEN
11 FEB 05 (13-2) Eff 17 Feb

JERSEY, UK
VOR DME Rwy 27

*ATIS 112.2		*JERSEY Approach (R) 120.3		*JERSEY Tower 119.45		*Ground 121.9 (Mar-Oct only)	
VOR JSY 112.2	Final Apch Crs 265°	Procedure Alt VOR 2000' (1729')	With DME MDA(H) 670' (399')	W/o DME MDA(H) 760' (489')	Apt Elev 277'	RWY 271'	
MISSED APCH: Climb STRAIGHT AHEAD. At 2000' or 2 Min, whichever is the later, turn LEFT to VOR at 2000' and hold. MAX IAS 185 KT.							1900'
Alt Set: hPa		Rwy Elev: 10 hPa		Trans level: By ATC		Trans alt: 3000'	

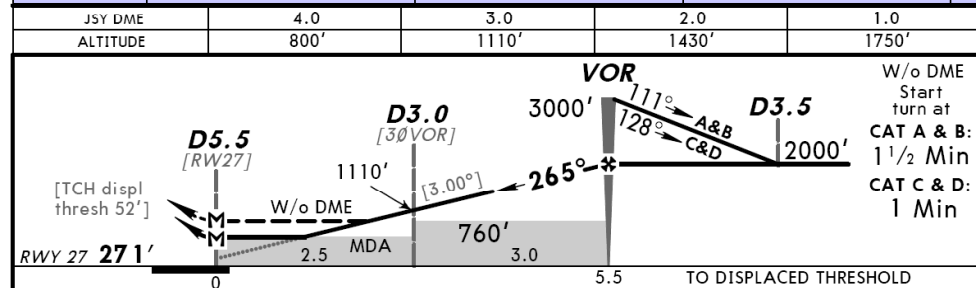
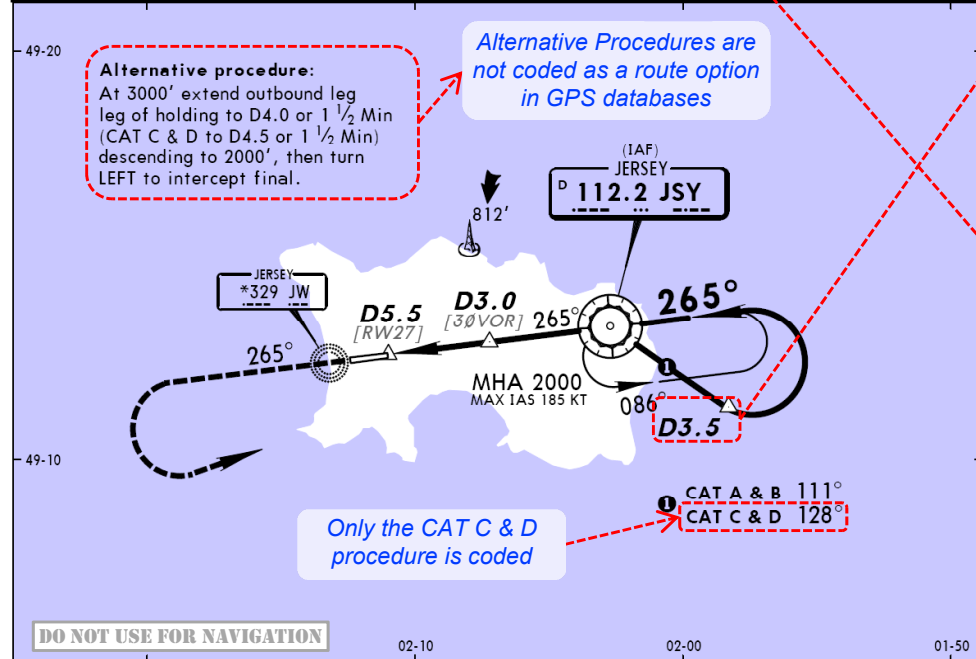

Garmin GNS530W procedure selection page



Note the discrepancy that this waypoint has a different name on the map display and the database waypoint list. Both variants are examples of a database identifier for a charted fix name where the bearing/distance convention is not used (which would have been "D128D" in this case). This occurs when an identifier like "D3.5" may be used because it is unique. Jersey has 6 approach charts, and "D3.5" appears only once, on this one. "D3.0" is not unique at Jersey, so it is given a CNF [30VOR], which happens to use a non-standard name

Garmin GNS530W flight plan waypoint list

Approach VOR/DME 27			
JSY	IA		
D3.5		128° _M	3.5 _{nm}
JSY	FA	265° _M	4.5 _{nm}
30VOR		265° _M	3.0 _{nm}
RW27	HA	265° _M	2.5 _{nm}
2000'		265° _M	3.4 _{nm}
JSY	HH		
hold		266° _N	01:00

This missed approach procedure leg has a conditional terminator for the turning point, "2000' or 2mins, whichever is later". It is coded as a notional fixed point in the procedure record, and will appear as such on the map display. The distance from the MAP is a notional 3.4nm, corresponding to approximately 100kts or a climb of 600' per nm. However, the GPS unit will not sequence automatically when this waypoint is reached – it is a manual termination leg, so the pilot must press the OBS key (in the Garmin 430/530; varies in other GPS units) to start guidance to the JSY when the 2000'/2min condition has been met.

Example of an ILS approach

EDDK/CGN **JEPPESEN** COLOGNE-BONN, GERMANY
 COLOGNE-BONN 8 DEC 06 (11-3) Eff 21 Dec ILS or LOC Rwy 32R

ATIS		COLOGNE-BONN Director (APP)		COLOGNE-BONN Tower (R)		Ground	
112.15	124.2	121.05		124.97		121.72	
LOC IKEN	Final Apch Crs	GS LOM	ILS DA(H)	Apt Elev 302'			
109.7	317°	1660' (1358')	502' (200')	RWY 302'			
MISSED APCH: Climb STRAIGHT AHEAD to D3.2 KBO or 2000', whichever is later, then turn RIGHT to COL VOR climbing to 5000'.							
Alt Set: hPa (IN on req)		Rwy Elev: 11 hPa	Trans level: By ATC		Trans alt: 5000'		
LOC: DME REQUIRED.							

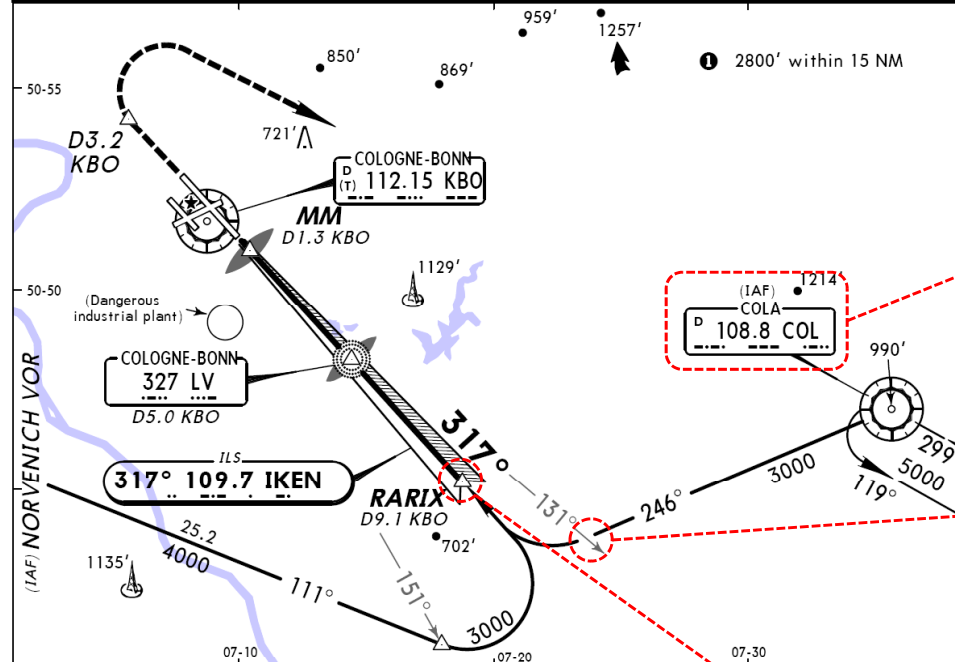
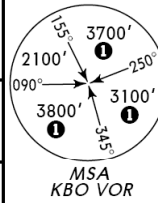

LOC	KBO DME	3.0	4.0	5.0	6.0	7.0	8.0	9.0
(GS out)	ALTITUDE	1030'	1340'	1660'	1980'	2300'	2620'	2940'

DO NOT USE FOR NAVIGATION

MM	LOM	RARIX
D1.3 KBO	D5.0 KBO GS 1660'	D9.1 KBO
		LOC 1660'
		3000'
		317°
		4.1

Garmin GNS530W procedure selection page

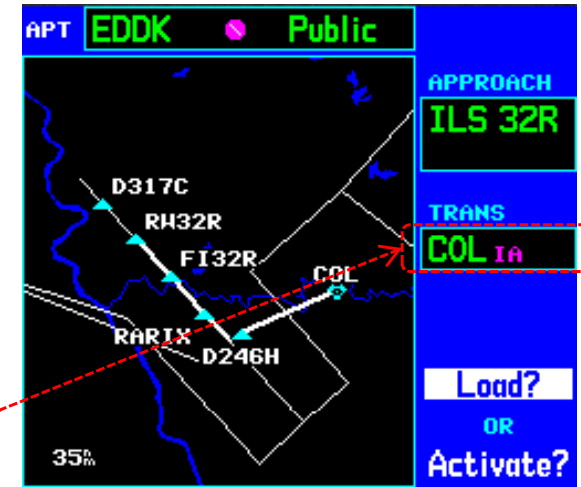

This is a conventional transition, the transition selections available for this procedure also include 'long' RNAV arrivals

Garmin GNS530W flight plan waypoint list

Approach ILS 32R		
COL IFA		
D246H	246°M	8.5nm
RARIX	317°M	3.0nm
FI32R FA	318°M	4.1nm
RW32R HA	318°M	4.2nm
D317C	317°M	3.5nm
2000f	317°M	3.4nm
COL		

A CNF is created in the coded procedure corresponding to the intersection between the COL 246 radial and the lead-in radial for the turn to the final approach (131 radial KBO)

Note that RARIX, the charted final approach point, is preceded by a turn from either of the two IAFs. Older FMS units cannot support a final approach fix without a prior waypoint on the final approach track. Hence, the database procedure uses RARIX as the final approach course fix and a CNF at the outer marker (FI32R) as the FAP. This is "discrepancy" exists only to support a technicality of older FMS units and illustrates why non-approved database overlays must not be used for primary guidance – a pilot flying this procedure must observe the published FAP at RARIX

Example of an RNAV(GPS) approach

(see also section 4 for more details on GPS approaches)

EDDK/CGN **JEPPESEN** COLOGNE-BONN, GERMANY
 COLOGNE-BONN 8 DEC 06 (12-6) Eff 21 Dec RNAV (GPS) Rwy 32R

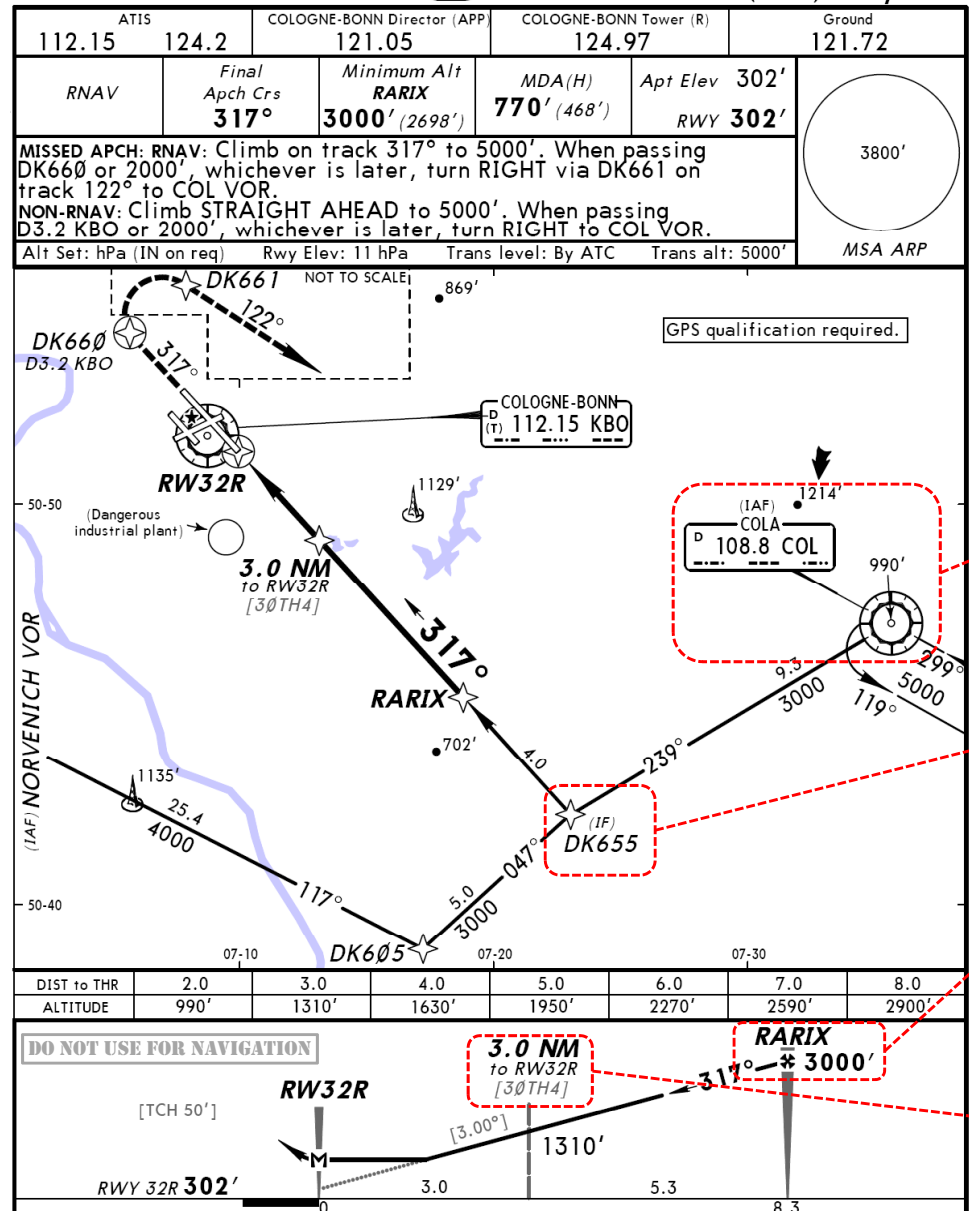

Garmin GNS530W procedure selection page



This is not a standard "T" shaped GPS approach, instead the IAFs correspond to the arrival route structure at EDDK

Garmin GNS530W flight plan waypoint list

Approach RNAV 32R		
COL IA		
DK655	239° _M	9.3 _{nm}
RARIX FA	317° _M	4.0 _{nm}
30TH4	317° _M	5.3 _{nm}
RW32R TH	317° _M	3.0 _{nm}
DK660	317° _M	3.0 _{nm}
2000'	317° _M	3.4 _{nm}
DK661		
COL	122° _M	19.4 _{nm}

GPS procedures generally have an Intermediate Fix on the final approach track (as in this case) so a "C" type final approach course fix CNF is not needed

Note that in this procedure, RARIX is coded as the Final Approach Fix (compare with the previous page)

The step down fix is coded with the published CNF identifier: the "30" refers to 3.0nm to the "TH" (Threshold), the "4" is a code number to be used to uniquely identify each of the CNFs at 3nm from threshold for different runways at EDDK

Example of a GPS 'published overlay' approach

LSGG/GVA
GENEVA

JEPPESEN
17 NOV 06
Eff 23 Nov (13-2)

GENEVA, SWITZERLAND
(GPS)VOR DME Rwy 23

ATIS 135.57	GENEVA Arrival (APP) 136.25	GENEVA Final (APP) 120.3	GENEVA Tower 118.7	Ground 121.67
VOR GVA 115.75	Final Apch Crs 226°	Procedure Alt D17.2 GVA 7000' (5635')	MDA(H) 1810' (445')	Appt Elev 1411' RWY 1365'
MISSED APCH: Climb on R-226 GVA to 4000'. At D4.0 GVA continue climb to 7000'. At D9.5 GVA turn LEFT (MAX 185 KT) to intercept and follow R-040 CBY to SPR VOR. For turns below 5000' MIM bank angle 25°.				
Alt Set: hPa	Rwy Elev: 49 hPa	Trans level: By ATC	Trans alt: 7000'	MSA GVA VOR

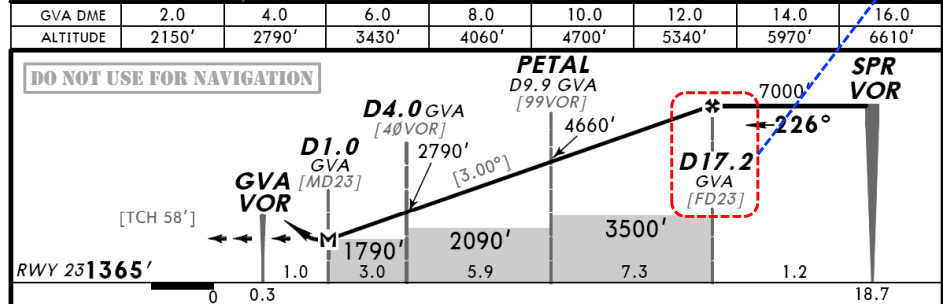
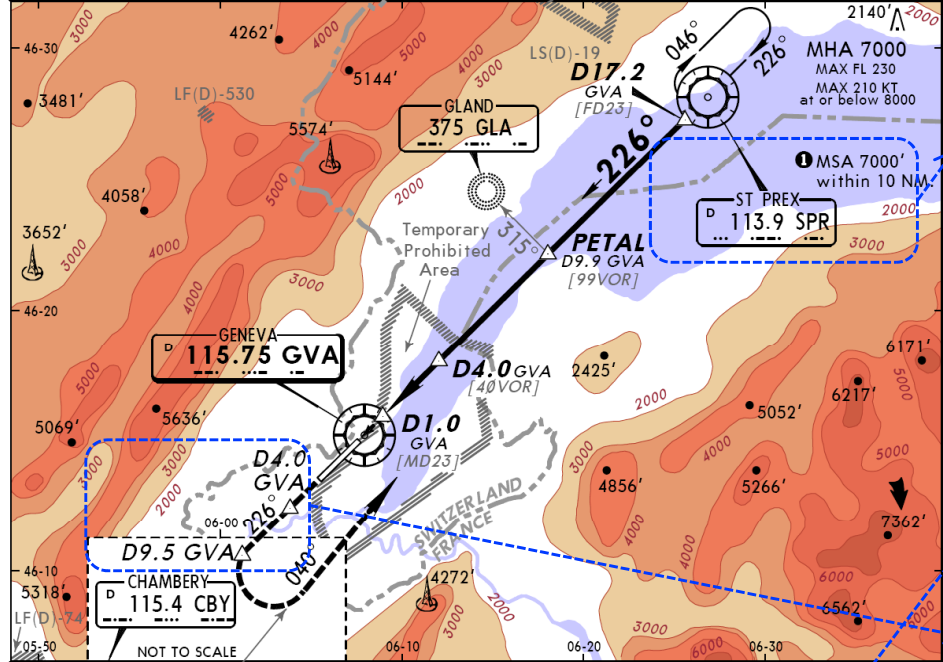

GPS

Garmin GNS530W procedure selection page

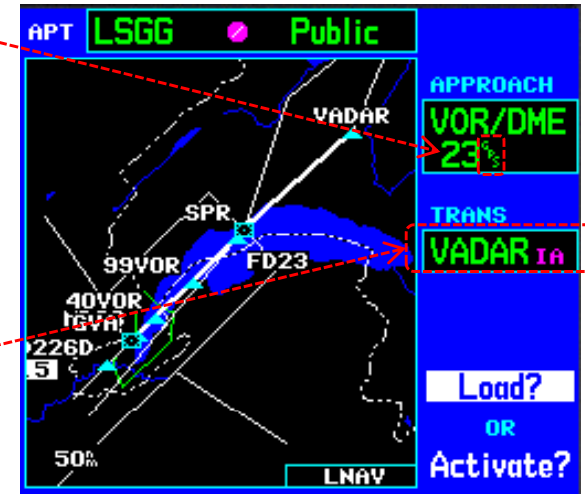

Note very small letters next to "23" denoting this is also a GPS approach

There is no "T crossbar" at the start of this procedure (in part, due to terrain) and SPR is not an IAF. All the IAFs for the procedure are on the STAR charts. VADAR is an example.

Garmin GNS530W flight plan waypoint list

VADAR IA			
SPR	228° _H	17.0 _n _m	
FD23 FA	217° _H	1.2 _n _m	
99VOR	226° _H	7.3 _n _m	
40VOR	226° _H	5.9 _n _m	
MD23 MA	226° _H	3.0 _n _m	
GVA	225° _H	1.0 _n _m	
D226D	226° _H	4.0 _n _m	
D9.5	226° _H	5.5 _n _m	
SPR MH	040° _H	28.0 _n _m	

Note that all the approach fixes on the chart have published CNF identifiers in faint grey

Note that "D9.5" is also the database identifier, whilst "D4.0" uses the bearing/distance convention to create the identifier "D226D". This is because there is only one "D.9.5" waypoint in the Geneva approach charts. "D4.0" is used several times in reference to different points and thus each instance of "D4.0" requires a unique CNF identifier

1. RNAV and RNP theory
 - a. Introduction
 - b. The Path-Terminator
 - c. RNAV procedure design
 - d. RNP principles
 - e. RNAV and RNP applications
2. GPS Navigators and their application to RNAV
 - a. The GPS system
 - b. Databases and Coding
 - c. Procedures
 - d. Error detection and warnings**
3. P-RNAV Terminal Procedures
 - a. P-RNAV requirements and approvals
 - b. P-RNAV training topics
 - c. P-RNAV operations
4. RNAV(GPS) Approach Procedures
 - a. GPS procedure types
 - b. GPS approach requirements and approvals
 - c. GPS approach operations
5. Avionics training
6. Simulator and/or Flight training

Principles of RAIM

1. The requirement for integrity monitoring

GPS receivers require a minimum of 4 satellites to establish a 3D position fix (see section 2a)



However, if a satellite develops a fault and broadcasts an inaccurate signal, this could result in an incorrect position solution

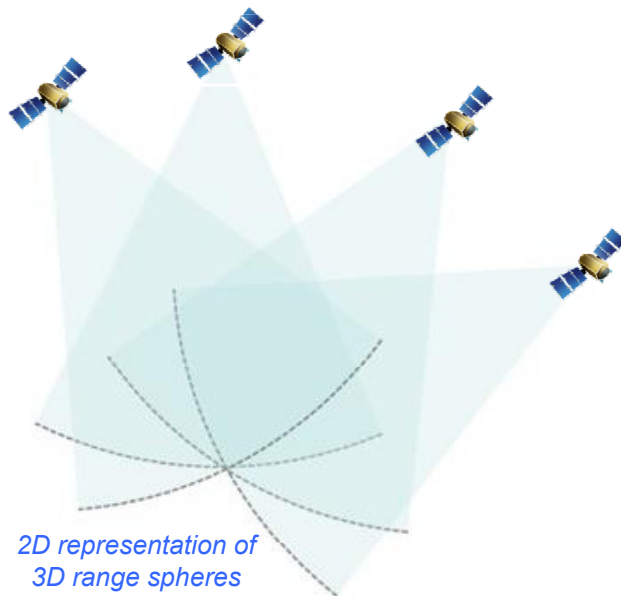

the faulty pseudorange can result in a navigation solution that appears to be valid but is inaccurate

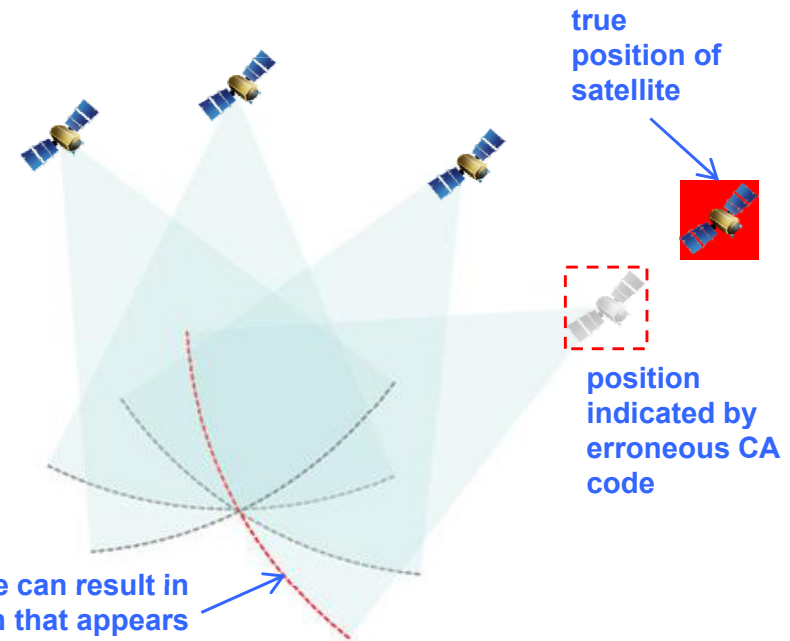

- The GPS Control Segment ground stations monitor satellites and detect faults
- However, the system may take up to 2hrs to detect to detect a fault and then update the Navigation Message to declare that a particular satellite signal is erroneous
- This potential delay means that IFR GPS receivers need an “autonomous” way of assuring the integrity of the navigation solution

Principles of RAIM

2. Fault detection and fault exclusion

A 5th satellite provides a GPS receiver with the capability for Fault Detection (FD)

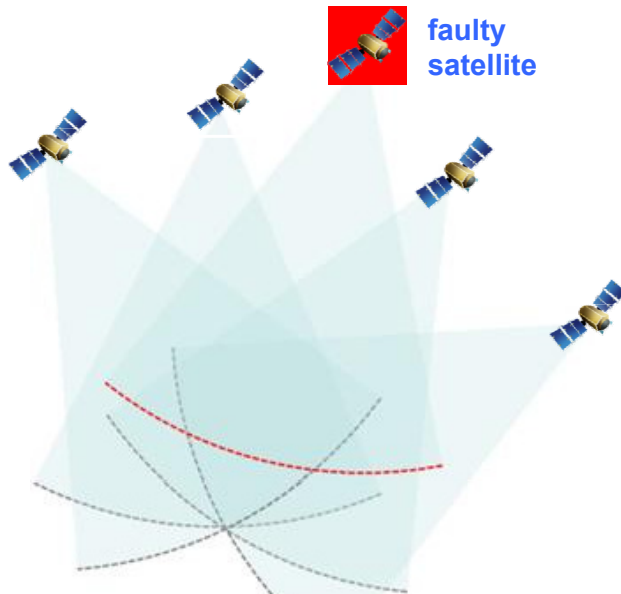

- The receiver can recognise that a satellite is faulty, because the 5 range spheres don't all intersect at a consistent point; but, because any combination of 4 satellites might provide a valid solution, it can not always identify which satellite is faulty
- RAIM (Receiver Autonomous Integrity Monitoring) is synonymous with Fault Detection (FD) and is a feature of all approved IFR GPS receivers



A 6th satellite provides a GPS receiver with the capability for Fault Detection and Exclusion (FDE)

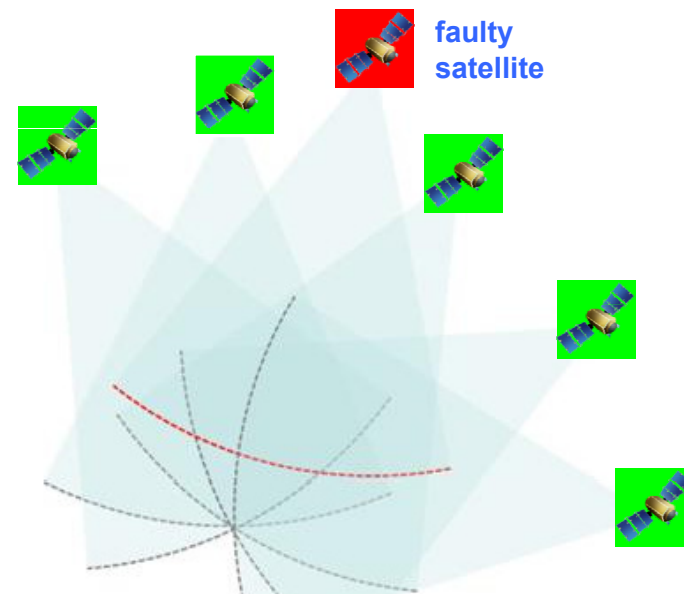

- The receiver can identify and isolate the faulty satellite, by finding which combination of 5 satellites will provide a self-consistent and valid navigation solution, and excluding the 6th
- Many TSO C129 receivers (eg. Garmin 430/530 with software version 3.0 or higher) and all TSO C146 receivers (eg. Garmin 430W/530W and 480) also feature RAIM with Fault Detection and Exclusion (FDE), which requires 6 visible satellites



• If RAIM is available, the GPS receiver can assure the integrity of its calculated position within a specified protection limit: 4 nm for oceanic, 2 nm for enroute, 1 nm for terminal and 0.3 nm for GPS approaches

Principles of RAIM

3. RAIM availability and requirements

Predicted RAIM availability

- Although, in practice, the GPS satellite constellation provides 6 or more visible satellites in almost all circumstances, this is not guaranteed
- On a particular route at a particular time, it may be that the “geometry” of the satellite constellation, or a known satellite failure, means that the minimum of 5 satellites needed for RAIM will not be available
- Such a lack of RAIM availability may be predicted, either by the GPS receiver software using almanac data and the time and route of flight, or by an internet-based RAIM prediction tool

Predicted RAIM availability requirements



Actual RAIM availability

- RAIM availability can be lost at any point in a flight if the number of visible, serviceable satellites falls below 5
- This may happen when RAIM was predicted to be available, if an unexpected satellite failure takes place
- All IFR GPS receivers will provide the pilot with a prominent alert if RAIM is lost at any point in flight – this does not mean the GPS position is wrong (eg. if 4 accurate satellite signals remain available) but it does mean that the integrity of the position is not assured (ie. one of the 4 signals could be erroneous)

Actual RAIM availability requirements



B-RNAV

RAIM prediction is not required before a B-RNAV route is flown using GPS, but it is advisable

A loss of RAIM availability does not mean that GPS navigation must be discontinued (as long as the GPS receiver is not also warning of a loss of GPS position) but the pilot should maintain a cross-check of position using conventional radio aids

P-RNAV

RAIM prediction must be conducted before a P-RNAV flight, and if there is a predicted lack of availability, the flight must either use alternative procedures or reschedule for a time when RAIM will be available

A loss of RAIM availability during a P-RNAV flight means that contingency procedures for the loss of P-RNAV capability must be followed (eg. advising ATC and requesting vectors or a conventional procedure)

RNAV(GPS) Approaches

Generally, RAIM prediction is required before conduction a flight which will use a GPS approach, eg. for the USA, see AIM Section 1-1-19 h and I, and for the UK, AIP Sup S 11/2008

A loss of RAIM availability means that the approach must be discontinued and the missed approach procedure flown. IFR GPS receivers will not activate an approach if RAIM is not available between the FAF and MAP

Methods of RAIM prediction

1. Eurocontrol's AUGUR internet site: <http://augur.ecacnav.com/>

- AUGUR is the approved RAIM prediction tool for flight in European airspace
- Use of this website complies with JAA TGL 10 Sub-section 10.2.1.3: "If a stand-alone GPS is to be used for P-RNAV, the availability of RAIM must be confirmed with account taken of the latest information from the US Coastguard giving details of satellite non-availability"

AUGUR NPA (Non-Precision Approach) prediction tool

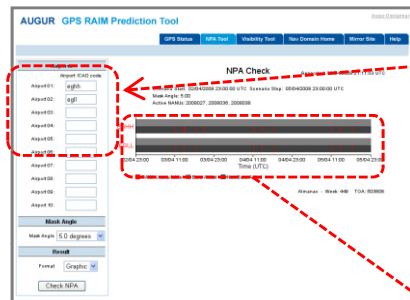

Airport ICAO codes entered

Airports and waypoints entered using database look-up tool

RAIM prediction displayed graphically over 24hrs

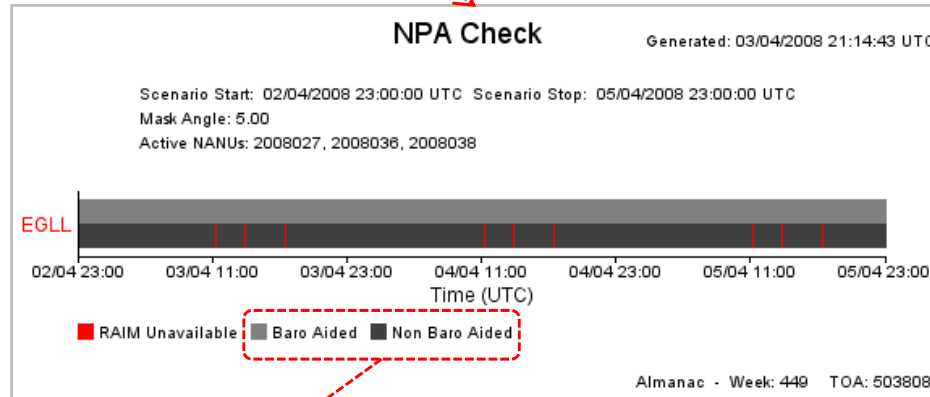

AUGUR Route prediction tool

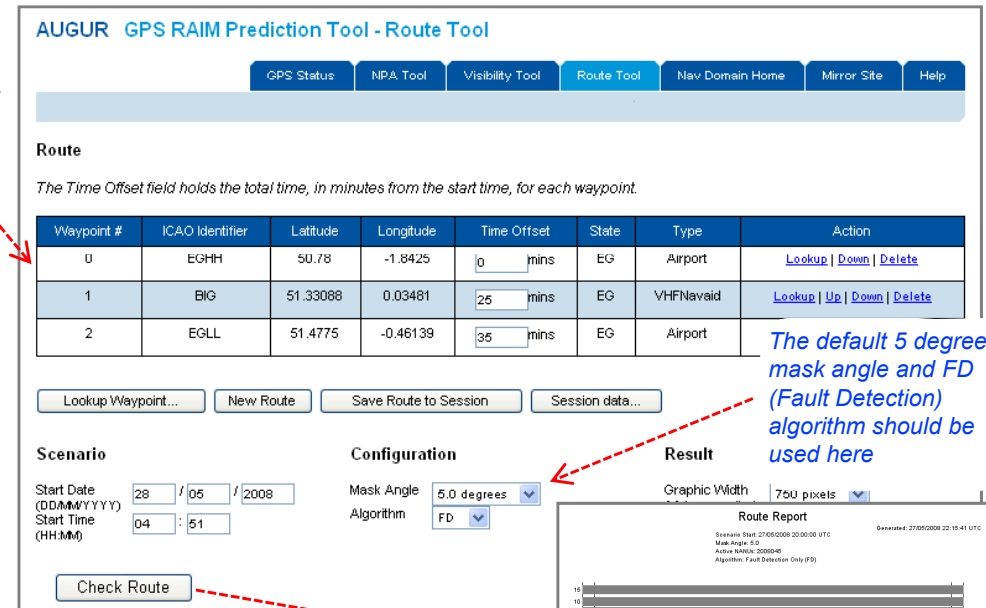

The Time Offset field holds the total time, in minutes from the start time, for each waypoint.

Waypoint #	ICAO Identifier	Latitude	Longitude	Time Offset	State	Type	Action
0	EGHH	50.78	-1.8425	0 mins	EG	Airport	Lookup Down Delete
1	BIG	51.33088	0.03481	25 mins	EG	VHFNavaid	Lookup Up Down Delete
2	EGLL	51.4775	-0.46139	35 mins	EG	Airport	Lookup Down Delete

Configuration: Mask Angle: 5.0 degrees, Algorithm: FD

The default 5 degree mask angle and FD (Fault Detection) algorithm should be used here

Route RAIM report generated for specified time of flight and 5min intervals either side

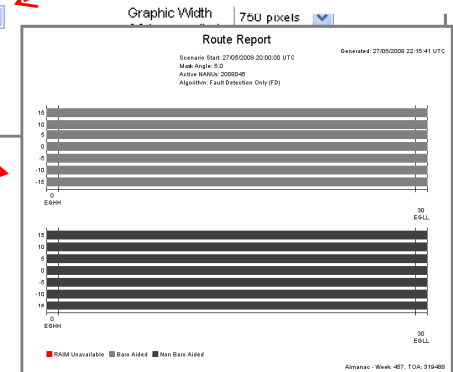

- "Baro Aiding" in this context means a GPS unit which can use a barometric altitude input as a substitute for a 4th satellite in determining a 3D position fix. Most IFR GPS installations will have such an altitude input as part of their certification requirements, allowing the less demanding (by 1 satellite) "baro-aided" prediction result to be used.
 - Note that this is completely different from the concept of baro-aiding in turbine aircraft FMS/GPS units that may use barometric input to provide a synthetic glideslope for baro-aided VNAV approaches.
- For a technical description of the AUGUR algorithms, see "RAIM Performance: How Algorithms Differ" by P.B. Ober, Delft University <http://www.integricom.nl/publications/ION%20GPS%201998%20RAIM%20Performance-How%20algorithms%20differ.pdf>

Methods of RAIM prediction

2. GPS receiver software

- All IFR GPS receivers can use the Almanac data in the Navigation Message to predict whether there will adequate satellite coverage to enable RAIM for a given time and route of flight

Example: Garmin 530 Pilot's Guide Section 10.3

Predicting RAIM availability:

- 1) Select 'RAIM Prediction' from the Utility Page, using the steps described at the beginning of this section.
- 2) The flashing cursor highlights the waypoint field. Use the small and large **right** knobs to enter the identifier of the waypoint at which the pilot wants to determine RAIM availability. Press the **ENT** Key when finished. (To determine RAIM availability for the present position, press the **CLR** Key, followed by the **ENT** Key.)
- 3) The flashing cursor moves to the arrival date field. Use the small and large **right** knobs to enter the date for which the pilot wants to determine RAIM availability. Press the **ENT** Key when finished.
- 4) The flashing cursor moves to the arrival time field. Use the small and large **right** knobs to enter the time for which the pilot wants to determine RAIM availability. Press the **ENT** Key when finished.
- 5) The flashing cursor moves to 'Compute RAIM?' (Figure 10-24). Press the **ENT** Key to begin RAIM prediction. Once calculations are complete, the GNS 530 displays one of the following in the RAIM status field:

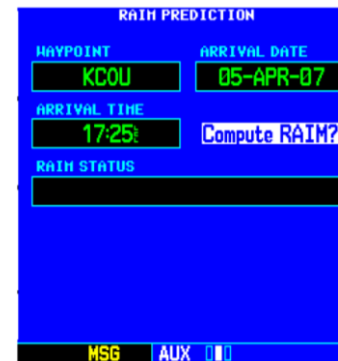

Figure 10-24 'Compute RAIM?' Highlighted

RAIM Not Available - Satellite coverage is predicted to NOT be sufficient for reliable operation during non-precision approaches

RAIM Available - Satellite coverage is predicted to be sufficient for reliable operation during all flight phases, including non-precision approaches

Methods of RAIM prediction

3. Note on use of GPS receiver software

- RAIM Fault Detection consists of two algorithms
 - a geometric screening, to calculate whether the available satellite geometry can provide a position fix of sufficient accuracy for the intended phase of flight
 - an error detection algorithm, to check whether any signals (in an otherwise adequate satellite geometry) are faulty
- RAIM prediction performed by a GPS receiver relies on the Almanac broadcast by GPS satellites. This may not have the most up to date information on the status of the satellite constellation

- The definitive source for this data is the US Coast Guard website:

<http://www.navcen.uscg.gov/navinfo/Gps/ActiveNanu.aspx>

- this site also provides the GPS equivalent of NOTAMs (“NANU”, Notice Advisory to Navstar Users)
- the USCG information is also available on the “Status” page of the AUGUR website, and is used in the AUGUR prediction tools

- ➔ **For this reason, an IFR GPS receiver’s built-in RAIM prediction may not comply with the requirements of some RNAV applications and approvals (particularly P-RNAV), and the AUGUR prediction tools must be used instead**

Note that RAIM prediction refers to the Fault Detection function (FD). RNAV applications requiring a predicted availability of Fault Detection and Exclusion (FDE), eg. GPS as a primary means of navigation on Oceanic routes, need the use of approved FDE prediction tools (eg. Garmin’s FDE software for the G430/530/1000 series)

Note that RAIM prediction is specific to the RNP requirement of a particular phase of flight – if RAIM is available for P-RNAV procedures (RNP-1) along a given route and time, this does not necessarily mean that it is available for GPS approaches (RNP-0.3): for example, a particular satellite geometry may have a dilution of precision that is acceptable for RNP-1 but not for RNP-0.3

AUGUR GPS RAIM Prediction Tool

GPS Status
NPA Tool
Visibility Tool

A minimum of 31 satellites are available during the query period.

B-RNAV en-route predictive RAIM check **not** required.

Scenario Information	
Scenario Start UTC	04/04/2008 00:00:00
Scenario End UTC	07/04/2008 00:00:00
Scenario Almanac	Week: 449 TOA: 589824
Request Time UTC	04/04/2008 13:36:51

Almanac Information	
Total Satellites	31
Unhealthy Satellite PRNs	0

Applicable Nanus			
NANU No.	Satellite PRN	Satellite Unavailable	
		From	To

GPS position warnings

1. The Loss of Integrity alert

- Whilst RAIM is available, the GPS receiver assures the integrity and accuracy of its calculated position within a protection limit specified for a particular phase of flight: 4 nm for oceanic, 2 nm for enroute, 1 nm for terminal (ie. the RNP-1 limit needed for P-RNAV) and 0.3 nm for GPS approaches

- Example, from the Garmin 530 Pilot's Guide:

- *The CDI scale in IFR GPS receivers automatically adjusts to the active phase of flight, or it may be set manually.*
- *CDI auto-scaling must be enabled for RNAV operations. Activating terminal and approach procedures from the GPS database ensures that the appropriate CDI scale and RAIM protection limits are applied*
- *In some GPS, units manually selecting a 1nm or 0.3nm CDI scale may not change the RAIM protection limit to the corresponding RNP value (although it does in the Garmin 430/530 series)*

CDI Scale/Flight Phase:	RAIM Protection:
Auto (oceanic)	4.0 nm
±5.0 nm or Auto (enroute)	2.0 nm
±1.0 nm or Auto (terminal)	1.0 nm
±0.3 nm or Auto (approach)	0.3 nm

- The “Loss of Integrity” (LOI) alert provided by a GPS receiver is very important. It is triggered by
 - a loss of RAIM availability, or
 - the detection of a fault in satellite signals which compromises position accuracy, or
 - an unfavourable satellite geometry and dilution of precision, such that position accuracy does not meet the protection limit required
- **The LOI alert indicates that the GPS may not be used as a source of primary guidance**
 - **during a P-RNAV procedure, the pilot must advise ATC of the RAIM failure and request radar vectors or a conventional alternative procedure**
 - **during a GPS approach, the pilot must initiate the missed approach and advise ATC**
- In practice, most instances of LOI are very brief. However, if an LOI alert persists for more than 60 seconds, it should be treated seriously and an appropriate contingency procedure initiated

Note: the protection provided by the RAIM function subsumes all of the integrity and accuracy requirements for RNAV; therefore the pilot need not be concerned with other measures of navigation accuracy the GPS unit may provide in the Status or Aux pages (eg. Estimated Position Error, Dilution of Precision and Horizontal Uncertainty Level)

GPS position warnings

2. Garmin 530 examples

- IFR GPS receivers always display the LOI alert prominently. In the Garmin 430/530 series, it is a black on yellow “INTEG” annunciator on the bottom left of the screen:
- In addition to the prominent LOI alert, the GPS will display one or more supplementary messages, either as pop-up overlays on the active screen, or within the Message screen (accompanied by a “MSG” annunciation).
- The user must be familiar with the meaning of all the alert and advisory messages in their GPS unit, and how they are annunciated and accessed

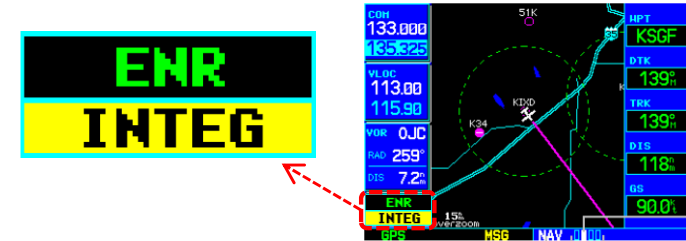

Example: Garmin GPS receiver status messages

Searching Sky	The GPS receiver is searching the sky for ANY visible satellites. The pilot is informed of this status with a 'Searching the Sky' message.
Acquiring Sat	The GPS receiver is acquiring satellites for navigation. In this mode, the receiver uses satellite orbital data (collected continuously from the satellites) and last known position to determine which satellites should be in view.
2D Navigation	The GPS receiver is in 2D navigation mode. Altitude data is provided by an altitude serializer.
3D Navigation	The GPS receiver is in 3D navigation mode and computes altitude using satellite data.
Poor Coverg	The GPS receiver cannot acquire sufficient satellites for navigation.
Rcvr Not Usbl	The GPS receiver is unusable due to incorrect initialization or abnormal satellite conditions. Turn the unit off and on again.
AutoLocate	The GPS receiver is looking for any available satellite. This process can take up to five minutes to determine a position.

Example: Garmin RAIM messages

RAIM is not available - Receiver Autonomous Integrity Monitoring (RAIM) has determined that sufficient GPS satellite coverage does not exist for the current phase of flight. (The CDI/HSI NAV flag also appears.) Select an alternate source for navigation guidance, such as the GNS 530's VLOC receiver.

RAIM position warning - Although sufficient GPS satellite coverage may exist, Receiver Autonomous Integrity Monitoring (RAIM) has determined the information from one or more GPS satellites may be in error. The resulting GPS position may be in error beyond the limits allowed for the current phase of flight. Cross-check the position with an alternate navigation source.

Degraded accuracy - GPS position accuracy has been degraded and RAIM is not available. Poor satellite geometry (or coverage) has resulted in a horizontal DOP greater than 4.0. Additional cross-checking using another navigation source is required to verify the integrity of the GPS position.

RAIM not available from FAF to MAP waypoints - When performing an instrument approach, Receiver Autonomous Integrity Monitoring (RAIM) has determined that sufficient GPS satellite coverage does not exist to meet the required protection limits. Select an alternate source for navigation guidance, such as the GNS 530's VLOC receiver

**JAA Administrative & Guidance Material
Section One: General Part 3: Temporary Guidance Leaflets**

**LEAFLET NO 10 Rev 1: AIRWORTHINESS AND OPERATIONAL APPROVAL FOR
PRECISION RNAV OPERATIONS IN DESIGNATED EUROPEAN
AIRSPACE**

This leaflet provides guidance material for the approval of aircraft and operations in the European region where Precision Area Navigation (P-RNAV) is required. It relates to the implementation of area navigation within the context of the European Air Traffic Management Programme (EATMP) and should be read in conjunction with EUROCONTROL document 003-93 (), Area Navigation Equipment: Operational Requirements and Functional Requirements.



10.2 Normal Procedures

10.2.1 Pre-flight Planning

.....

10.2.1.3 If a stand-alone GPS is to be used for P-RNAV, the availability of RAIM must be confirmed with account taken of the latest information from the US Coastguard giving details of satellite non-availability.

Note: RAIM prediction may be a function of the equipment provided that satellite non-availability data can be entered. In the absence of such a function, an airspace service provider may offer an approved RAIM availability service to users.

 SUPPLEMENTS TO THE UNITED KINGDOM AIP	S 11/2008	
	Publication Date: 24 April	
NATS Limited Aeronautical Information Service Control Tower Building, London Heathrow Airport Hounslow, Middlesex TW6 1JJ Editorial: 020-8745 3457 Fax: 020-8745 3453 Distribution: 0870-8871410 Contact: 020-7453 6518 (CAS) AFTN: EGGNYNYX Website: www.ais.org.uk	NOTES: (a) All times are UTC. (b) References are to the UK AIP. (c) Information, where applicable, should also be used to amend appropriate charts.	
UK RNAV (GNSS) INSTRUMENT APPROACH PROCEDURES		

10 Pre-Flight Planning

10.1 Aircraft operators shall ensure that the appropriate coverage from GNSS is provided for the intended flight. Receiver Autonomous Integrity Monitor (RAIM) availability prediction should take into account the GPS constellation predicted for the duration of the flight, NOTAM and avionics architecture eg, Baro aiding input. Software tools available on the Internet can be used for this purpose eg AUGUR⁴ or through the aircraft navigation system RAIM prediction capability, if provided. In the event of a predicted, continuous loss of appropriate level of fault detection of more than five (5) minutes for any part of the RNAV (GNSS) approach procedure, the flight planning should be revised eg, delaying the departure or planning a different approach procedure.

10.2 RAIM availability prediction software does not guarantee the service; they are tools to assess the expected capability to meet the required navigation performance. Because of failure of some GNSS elements, operators must be aware that RAIM, or GPS navigation altogether, may be lost while airborne which may require reversion to an alternative means of navigation. Therefore, pilots should assess their capability to navigate (potentially to an alternate destination) in case of failure of GPS navigation.

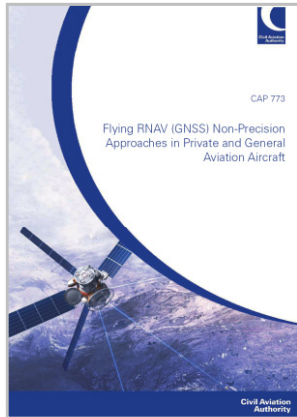

Flying RNAV (GNSS) Non-Precision Approaches in Private and General Aviation Aircraft

RAIM Prediction

During the pre-flight planning phase, the availability of RAIM (or equivalent monitor) at the destination should be verified as closely as possible before take-off, and in any event, not more than 24 hours before take-off (RAIM should be available from 15 minutes before the Estimated Time of Arrival (ETA) until 15 minutes after ETA). This may be established either by an internal function of the receiver (Note 1) or an Air Navigation Service Provider (ANSP) may offer an approved RAIM availability service to users (for example: <http://augur.ecacnav.com/npa.html>) (Note 2).

NOTE 1: Receiver-based RAIM prediction programmes are not able to predict short notice 'outages' and failures, and will not take account of scheduled disruptions to the satellite signals. Consequently, a receiver-based RAIM prediction may appear sound when the actual availability proves insufficient to provide the RAIM function. RAIM predictions do not normally take account of terrain above the horizon. Where terrain interrupts the 'view' of a satellite from the receiver as the aircraft descends on approach, availability may be affected.

NOTE 2: Research has shown that such independently available RAIM prediction tools may not have the latest accurate availability data and are also unable to predict short notice outages and failures. A RAIM prediction from these service providers is also not guaranteed.

1. RNAV and RNP theory
 - a. Introduction
 - b. The Path-Terminator
 - c. RNAV procedure design
 - d. RNP principles
 - e. RNAV and RNP applications
2. GPS Navigators and their application to RNAV
 - a. The GPS system
 - b. Databases and Coding
 - c. Procedures
 - d. Error detection and warnings
3. P-RNAV Terminal Procedures
 - a. P-RNAV requirements and approvals**
 - b. P-RNAV training topics
 - c. P-RNAV operations
4. RNAV(GPS) Approach Procedures
 - a. GPS procedure types
 - b. GPS approach requirements and approvals
 - c. GPS approach operations
5. Avionics training
6. Simulator and/or Flight training

Introduction: the “compliance” and “authorisation” models of regulation

- P-RNAV approval differs from the style of regulation most private GA operators are familiar with
- The “compliance model” for private IFR (or VFR) defines individual, independent criteria that must be met for a flight to be legal, for example
 - aircraft certification and equipment
 - pilot qualifications and currency
 - operational requirements (such as fuel reserves and weather minima)
- If these independent criteria are met, a private flight is permissible – they are both a necessary and sufficient condition. For example, any IFR-certified aircraft may be (privately) operated under IFR anywhere in the world by any pilot holding the appropriate pilot qualification and instrument rating
- In the commercial world, a different kind of regulation applies: it is an “authorisation model”, rather than a “compliance” one. Commercial operators need specific authorisation for individual aircraft types, routes, operating procedures, weather minima, minimum equipment lists, training programmes etc. which form the “OpSpecs” (Operations Specifications) that the aviation authority of the State regulating the operator is responsible for approving and monitoring
- A small number of IFR applications require operational approval (in the form of a “Letter of Authorisation”, LoA) for all operators, not just commercial ones. This is an established principle under ICAO, although, prior to P-RNAV, such applications have not been relevant to piston aircraft. For example, private turbine aircraft flying in RVSM airspace (Reduced Vertical Separation Minima, usually above FL290 up to FL410) require the same kind of RVSM LoA as commercial operators
- The LoA is the responsibility of, and issued by, the State of Registry, which interprets the guidance agreed under ICAO for a particular application (including ‘regional’ ones, such as P-RNAV) and publishes requirements operators must meet
 - it is necessary, but not sufficient, for an operator to meet these requirements (eg. having an RVSM equipped aircraft, having pilots trained in RVSM procedures, using appropriate checklists). The operator must, in addition, specifically apply for and be granted an LoA

• Approval for P-RNAV operations is analogous to RVSM: private GA operators require a P-RNAV Letter of Authorisation

Note: this requirement is not specific to any one country, all ICAO states have to follow the LoA method defined by Europe for P-RNAV approval. However, in the USA, RNAV 1 has similar requirements to P-RNAV (see FAA AC 90-100A) but the “compliance model” is used for Part 91 (private) operators

Introduction to JAA TGL 10

<http://www.ecacnav.com/downloads/TGL10%20rev.1.pdf>



- The JAA's TGL (Temporary Guidance Leaflet) 10 is the basic source of guidance on P-RNAV approval
- 'Revision 1' is the current version, as of April 2008
- Because P-RNAV LoAs are the responsibility of the State of Registry, each national aviation authority implements an LoA process based on TGL10

JAA TGL10

JAA Administrative & Guidance Material
Section One: General Part 3: Temporary Guidance Leaflets

LEAFLET NO 10 Rev 1: AIRWORTHINESS AND OPERATIONAL APPROVAL FOR PRECISION RNAV OPERATIONS IN DESIGNATED EUROPEAN AIRSPACE

This leaflet provides guidance material for the approval of aircraft and operations in the European region where Precision Area Navigation (P-RNAV) is required. It relates to the implementation of air navigation within the context of the European Air Traffic Management Programme (EATMP) and should be read in conjunction with EUROCONTROL document 001-2012-01, Area Navigation Equipment Operational Requirements and Functional Requirements.

TABLE OF CONTENTS

- 1. INTRODUCTION
- 1.1 PURPOSE
- 1.2 SCOPE
- 2. REFERENCE DOCUMENTS
- 2.1 Related Requirements
- 2.2 Related Guidance Material
- 3. ASSUMPTIONS
- 4. SYSTEM DESCRIPTION
- 4.1 Lateral Navigation
- 4.2 Vertical Navigation
- 5. AIRWORTHINESS CERTIFICATION OBJECTIVES FOR RNAV SYSTEMS
- 5.1 Accuracy
- 5.2 Integrity
- 5.3 Continuity of Function
- 6. FUNCTIONAL CRITERIA
- 6.1 Approval Function
- 6.2 Performance
- 6.3 Operational Accuracy
- 7. ACCEPTABLE MEANS OF AIRWORTHINESS COMPLIANCE
- 7.1 General
- 7.2 Continuity Integrity
- 7.3 Use of GPS Equipment
- 7.4 Use of Weather Data
- 7.5 Monitoring of Equipment
- 8. AIRCRAFT FLIGHT MANUAL
- 9. OPERATIONAL CRITERIA
- 9.1 General
- 9.2 Normal Procedures
- 9.3 Contingency Procedures
- 9.4 Crew Resource Management
- 9.5 Flight Crew Training
- 9.6 Pilot/Operator Proficiency
- 9.7 Pilot/Operator Documentation

Annex A: Abbreviations
Annex B: Useful Charts
Annex C: Examples of Operational Terminal Airspace Procedures for P-RNAV
Annex D: Flight Manual Change Sheet Template

Section 10403-3 10-1 087 updated February 08



An overall guide to RNAV approvals, refers applicants to TGL10

Application form for P-RNAV LoAs and other RNAV approvals

UK operators send these to the CAA Safety Regulation Group's Flight Operations Policy (Admin) team

For example:

FAA's AC90-96A



Advisory Circular

Subject: APPROVAL OF U.S. OPERATORS TO CONDUCT P-RNAV OPERATIONS IN EUROPEAN AIRSPACE DESIGNATED FOR P-RNAV AREA NAVIGATION (P-RNAV) AND PRECISION AREA NAVIGATION (P-RNAV)

1. PURPOSE

a. This advisory circular (AC) provides operational approval and aeronautical guidance material regarding Area Navigation (RNAV) operations in the airspace of U.S.-registered aircraft operating in Europe. This AC is issued to U.S.-registered aircraft operators to inform them of the requirements for P-RNAV operations in Europe. The FAA is responsible for P-RNAV LoAs.

Describes LoA requirements based on TGL10

For US-registered aircraft based in Europe, the New York International Field Office of the FAA is responsible for P-RNAV LoAs

UK CAA's FODCOM 04/2008

**SAFETY REGULATION GROUP
FLIGHT OPERATIONS
DIVISION COMMUNICATION**

04/2008

Applicability: All AOC Holders

AREA NAVIGATOR (RNAV) - CAA GUIDANCE MATERIAL

1. Introduction

1.1 It is noted that there have been a number of developments in the use of aircraft RNAV systems in Europe for operations, arrival and final approach to landing. In response to these developments the CAA has produced guidance material for operators engaged in RNAV. This guidance was published in FODCOM 2007/07.

2. Issue

2.1 This document provides guidance on flight crew training, operational issues and operational approval requirements for RNAV operations. It provides a clear statement of the terminology related to RNAV. It addresses the use of RNAV, various types of RNAV and their associated equipment (RNAV, RNP, CDS and RNP-3D), as well as the use of RNAV systems. It provides a clear statement of operational approval requirements for RNAV operations. It also provides a clear statement of operational approval requirements for RNAV operations. It also provides a clear statement of operational approval requirements for RNAV operations.

and CA4045

UK Civil Aviation Authority

AREA NAVIGATION APPROVALS INCLUDING P-RNAV, RNAV APPROACH AND GROSS APPROACH OPERATIONS

APPLICATION FOR AN RNAV OPERATIONAL APPROVAL/RENEWAL

Please complete the form in BLOCK CAPITALS using black ink and refer to the attached guidance.

This form is designed to elicit all the required information from those operators requiring Precision Area Navigation (P-RNAV), RNAV, Approach or GROSS approach operations approval. Sections 1 and 2 should be completed in all cases. Completed forms should be submitted to the Flight Operations Policy (Commercial) Section of the Safety Regulation Group at the address listed in the Notes for Completion.

Applicants are strongly advised to read the 'Notes for Completion' before completing the form.

Section I Page 1 Operator Airline Details Completion mandatory

Section II Page 2 RNAV Operational Approvals Completion mandatory

Section III Page 3-5 Signature Block/Notes Completion mandatory

Section IV Page 6 Form Details Communication Sheet

SECTION I - OPERATOR/AFRAME DETAILS

APPLICANT DETAILS - required for all approval requests

1. Please give the official name and business or trading name(s), address, mailing address, e-mail address and contact number/number(s) of the applicant. (Use reverse)

Applicant Type	Applicant Name	Applicant's Address	Registration	Home "P" Code (if any)

(Use continuation sheet provided on page 6, if necessary)

Form CA4045 issue 1 (2007) Page 1 of 6



• Although individual States are responsible for issuing P-RNAV LoAs, all the national requirements are essentially those of JAA TGL10

Overview of the JAA TGL10 document



- TGL10 is a relatively concise and accessible document. There is a significant amount of material which describes operational requirements for commercial aircraft and the features older Flight Management Systems need to comply with P-RNAV; this does not concern the private GA operator. The only essential requirements for a single-pilot light aircraft are a compliant IFR GPS installation and appropriate pilot training and operating procedures

Section	Comment
1. Purpose	Introductory paragraph. Importantly, it emphasises that TGL10 is <u>not compulsory</u> : an LoA applicant may elect to use an alternative means of compliance that meets the objectives of TGL10 and satisfies the authority of the State of Registry
2. Scope	Describes what is covered in TGL10, and what P-RNAV means in operational terms
3. Reference Documents	Lists many regulatory and technical documents relating to P-RNAV from ICAO, the JAA, the FAA and Eurocontrol
4. Assumptions	Describes various navigation, airspace and operational principles that P-RNAV depends upon: eg. design criteria for procedures, performance of the GPS system, availability of alternative procedures
5. System Description	Lists the various kinds of navigation sensors that may be used in P-RNAV (eg. GPS, DME/DME, IRS)
6. Airworthiness Objectives	Describes the accuracy, integrity and continuity performance needed for an avionics installation to be TGL10-compliant
7. Functional Criteria	Lists the 21 avionics system functions required for P-RNAV, and 6 recommended functions
8. Acceptable Means of Airworthiness Compliance	Describes the various means by which an aircraft avionics installation may be demonstrated to be compliant with TGL10 (eg. manufacturer certification for new OEM installations vs. operator's compliance statement for retrofit equipment). Also refers to GPS TSO requirements and database integrity standards
9. Aircraft Flight Manual	States that either the aircraft Flight Manual or an operator's compliance statement must identify the avionics installation as having RNP-1 or better capability
10. Operational Criteria	Provides guidelines for P-RNAV operating procedures and pilot training

-  • **Sections 7 and 10 are particularly relevant for GA pilots: they detail the avionics features, pilot training and operating procedures needed for P-RNAV**



- TGL10 and the appropriate National Aviation Authority (NAA) guidance material (eg. FAA AC90-96A, CAA FODCOM 04/2008) need to be studied in detail by any P-RNAV LoA applicant. However, the key P-RNAV requirements for a private operator of a non-FMS equipped aircraft may be summarised as follows:

1. Avionics installation	2. Pilot knowledge and training	3. Operations manual
<ul style="list-style-type: none"> • TGL10 section 8.3.1 states <i>“The use of GPS to perform P-RNAV operations is limited to equipment approved under FAA TSO-145 and TSO-146, and JTSO-C129a/TSO C129 in the equipment classes A1, B1, C1, B3 and C3 and which support the minimum system functions specified in Section 7”</i> • The TSO/JTSOs requirement is met by most modern panel-mount IFR GPS units (eg. the Garmin 400,500,1000 series and B/K KLN94) • The section 7 functional requirements are typically met by an IFR-approved installation with a flight manual entry approving the use of the GPS for terminal procedures. A coupled HSI is probably required, an autoslewing (E)HSI is not. • An autopilot is not required • If the installation (including annunciators and nav indicators) is approved for the more demanding RNP-0.3 of GPS approaches, it is likely to be suitable for P-RNAV • A database supplier with a Type 2 LoA or equivalent is also required (see section 2b) • However, the ultimate decision on P-RNAV airworthiness approval rests with the NAA 	<p>Ground training</p> <ul style="list-style-type: none"> • TGL10 section 10.5 states that pilots must receive appropriate training in <ul style="list-style-type: none"> – the P-RNAV operating guidelines in sections 10.2 and 10.3 – the Theory subjects in table 3 section 10.5 • Section 3b of this manual details how it can be used to comply with these ground training requirements <p>Flight/Simulator training</p> <ul style="list-style-type: none"> • TGL10 section 10.5 only states that <i>“where practicable standard training events (simulator checks/proficiency checks) should include departures and arrivals using the RNAV based procedures”</i> • NAAs define their own training requirements. For example, in an FAA LoA application, the operator needs to report the training methods proposed. Appendix C of FODCOM 04/2008 details the training the UK CAA requires for P-RNAV • Section 6 of this manual includes a syllabus intended to meet such NAA requirements 	<ul style="list-style-type: none"> • TGL10 section 10.7 states that <i>“the aircraft Operations Manual....and checklists must be revised to take account of...the operating procedures in paragraphs 10.2 (Normal Procedures) and 10.3 (Contingency procedures)”</i> • In the author’s interpretation of TGL10, 3 methods of compliance should be acceptable <ul style="list-style-type: none"> – amending an existing operations manual to comply with 10.7 – writing an “extended checklist” for the aircraft to comply with 10.7 – writing a flight manual supplement to cover P-RNAV operations, as per TGL10 section 9.2, which states that this is acceptable for an aircraft without an operations manual • PPL/IR Europe recommends that an “extended checklist” form of operations manual, with appropriate standard operating procedures, is used for private, single-pilot IFR. A template for such manuals is available to members at the www.pplir.org website. Modifying such a checklist/manual to include the P-RNAV items of TGL10 sections 10.2 and 10.3 is our suggested method of compliance • If the aircraft is operated with a Minimum Equipment List (MEL) this must be amended to refer to P-RNAV requirements

-  • **Sections 3b of this manual details how it may be used to meet the pilot knowledge and training requirements of TGL10, and section 3c provides guidelines for developing a compliant P-RNAV “extended checklist”**

An informal guide to getting a P-RNAV LoA

Example for an aircraft with an IFR approved Garmin 430, 530 or 1000 installation (OEM or retrofit)

	1. Avionics installation	2. Pilot knowledge and training	3. Operations manual	4. Application process
FAA 	<ul style="list-style-type: none"> • Compile documents demonstrating IFR approval status for Terminal Procedures <ul style="list-style-type: none"> – Flight Manual pages for OEM installations – Flight Manual Supplement and Form 337 (if appropriate) for retrofits – Garmin’s TGL10 compliance statement; see http://www.ecacnav.com/content.asp?CatID=208 	<ul style="list-style-type: none"> • Document the training that has/will be used for pilots operating under the LoA to acquire and maintain currency in the requirements detailed in AC90-96A Appendix 1.3 and Appendix 2.3 and 2.4 (essentially those of TGL sections 10.2, 10.3 and 10.5) • A statement that this Manual has been studied, and describing the pilots’ IFR GPS initial and recurrent training may suffice. A CFII or DPE endorsement of both should suffice 	<ul style="list-style-type: none"> • Prepare an “extended checklist” or operations manual, consistent with the aircraft Flight Manual, to comply with AC90-96A Appendix 2.3 • The guidelines in Section 3c of this manual should be adequate for this purpose 	<ul style="list-style-type: none"> • For operators based in Europe, submit items 1-3 to the FAA’s New York International Field Office • For operators based in the USA, submit these to the local FAA Flight Standards District Office (FSDO)
UK CAA 	<ul style="list-style-type: none"> • Engage with Avionics Maintenance organisation to obtain a P-RNAV airworthiness compliance statement acceptable to the CAA • Prepare a description of the avionics system and navigation indicators used for P-RNAV • Document database supplier compliance • Document MEL references to P-RNAV, if appropriate 	<ul style="list-style-type: none"> • Document the training that has/will be used for pilots operating under the LoA to acquire and maintain currency in the requirements detailed in pages 9 and 11 of CAA FODCOM 04/2008 • PPL/IR Europe will be seeking approval that this Manual and the training syllabus in Section 6 meet these requirements if undertaken by an Instrument Rating instructor or examiner 	<ul style="list-style-type: none"> • Prepare an “extended checklist” or operations manual, consistent with the aircraft Flight Manual, to comply with CAA form CA4045 “Notes for Completion of Section II paragraph 3” and TGL10.2 and 10.3 • The guidelines in Section 3c of this manual should be adequate for this purpose 	<ul style="list-style-type: none"> • Complete CAA Form CA4045, prepare the attachments required by this form, and submit these to the CAA address on page 5 of CA4045

➔ **P-RNAV approval is in its “infancy” for private single-pilot aircraft operators, so this summary is only an informal guide. The definitive sources are the appropriate JAA and NAA documents, which may have changed since this manual was written. NAAs have full and final discretion on issuing LoAs, and no third party document, such as this one, can give any assurance on the requirements that will be applied**

Reference: Eurocontrol Navigation Domain website www.ecacnav.com

<http://www.ecacnav.com/content.asp?CatID=208>

Many useful resources and documents, well worth browsing

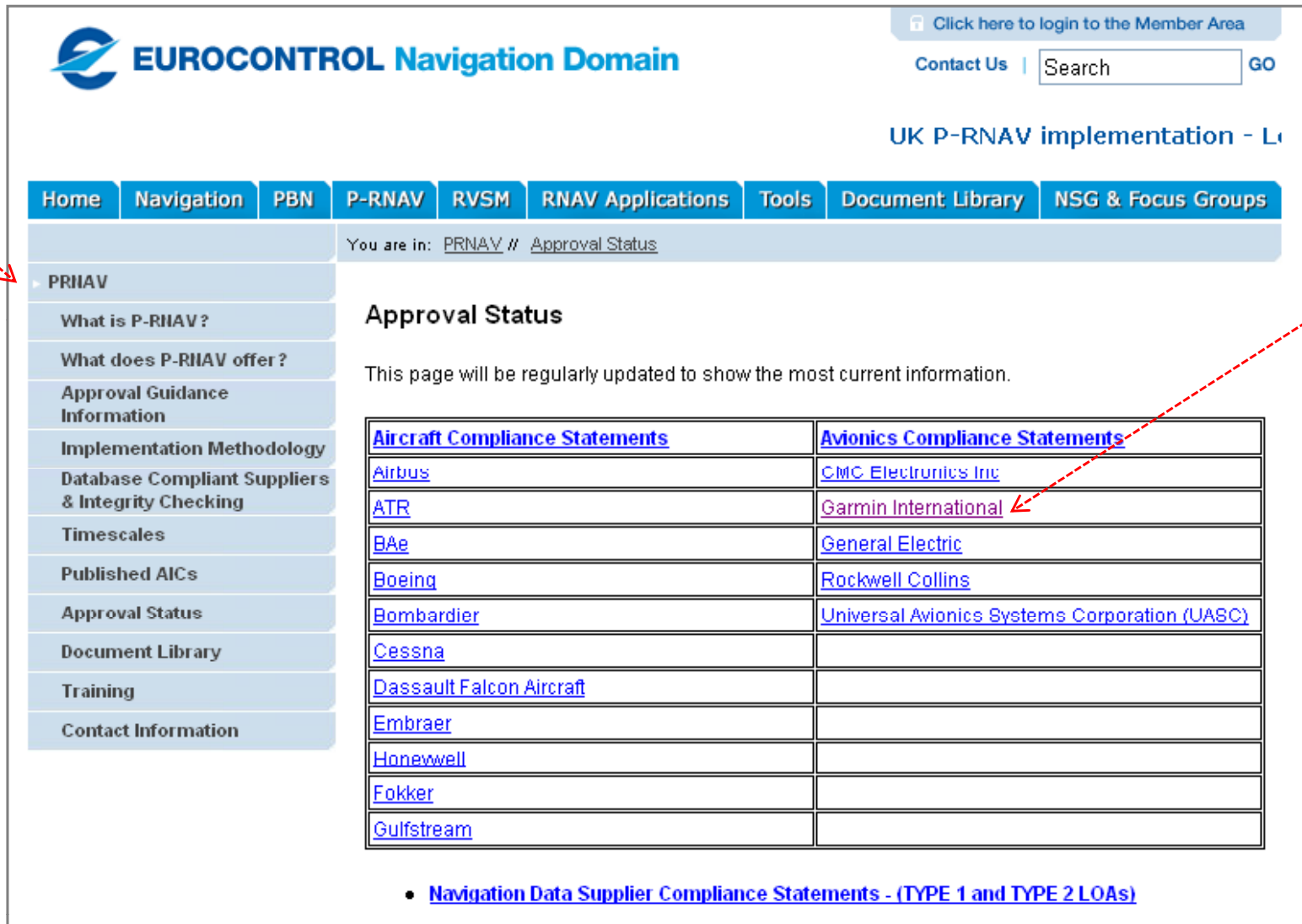

The screenshot shows the Eurocontrol Navigation Domain website. The main header includes the logo and the text 'EUROCONTROL Navigation Domain'. There are navigation tabs for Home, Navigation, PBN, P-RNAV, RVSM, RNAV Applications, Tools, Document Library, and NSG & Focus Groups. The current page is titled 'UK P-RNAV implementation - L'. A sidebar on the left contains a list of links: PRIAV, What is P-RNAV?, What does P-RNAV offer?, Approval Guidance Information, Implementation Methodology, Database Compliant Suppliers & Integrity Checking, Timescales, Published AICs, Approval Status, Document Library, Training, and Contact Information. The main content area is titled 'Approval Status' and contains a table with two columns: 'Aircraft Compliance Statements' and 'Avionics Compliance Statements'. The table lists various aircraft manufacturers and their corresponding avionics suppliers. A red dashed arrow points from the text 'Many useful resources and documents, well worth browsing' to the 'PRIAV' link in the sidebar. Another red dashed arrow points from the text 'Garmin 400, 500 and 1000 series compliance statements' to the 'Garmin International' link in the 'Avionics Compliance Statements' column of the table.

Click here to login to the Member Area

Contact Us | Search GO

UK P-RNAV implementation - L

Home Navigation PBN P-RNAV RVSM RNAV Applications Tools Document Library NSG & Focus Groups

You are in: P-RNAV / Approval Status

PRIAV

- What is P-RNAV?
- What does P-RNAV offer?
- Approval Guidance Information
- Implementation Methodology
- Database Compliant Suppliers & Integrity Checking
- Timescales
- Published AICs
- Approval Status
- Document Library
- Training
- Contact Information

Approval Status

This page will be regularly updated to show the most current information.

Aircraft Compliance Statements	Avionics Compliance Statements
Airbus	CMC Electronics Inc
ATR	Garmin International
BAe	General Electric
Boeing	Rockwell Collins
Bombardier	Universal Avionics Systems Corporation (UASC)
Cessna	
Dassault Falcon Aircraft	
Embraer	
Honeywell	
Fokker	
Gulfstream	

- [Navigation Data Supplier Compliance Statements - \(TYPE 1 and TYPE 2 LOAs\)](#)

Garmin 400, 500 and 1000 series compliance statements

A P-RNAV LoA is issued to an “operator”. What does this mean in practice?



- For the purposes of private general aviation, an “operator” is the person, organisation or business that exercises operational control over an aircraft
- This “operational control” is distinct from the duties of the pilot in command. For example, the operator may control the circumstances in which the aircraft is flown, whilst the pilot is responsible for executing the flight
- The operator is not necessarily the legal owner of the aircraft, since the aircraft may be leased or hired by the operator, or it may be owned by a trust on behalf of the operator

Examples of some possible ‘combinations’ of owner, operator and pilot:

Owner	Operator	Pilot
<ul style="list-style-type: none"> • A private aircraft is owned by a person who is also the operator and pilot 		
<ul style="list-style-type: none"> • A private aircraft is owned by a person, organisation or business who is also the operator 	<ul style="list-style-type: none"> • A pilot hires or borrows an aircraft from the operator • The operator hires or otherwise engages a pilot 	
<ul style="list-style-type: none"> • A private aircraft is owned by a person, organisation or business who is not the operator 	<ul style="list-style-type: none"> • A person is the operator of the aircraft under an arrangement with the owner, that person is also the pilot of the aircraft 	
	<ul style="list-style-type: none"> • A person, organisation or business is the operator of the aircraft under an arrangement with the owner 	<ul style="list-style-type: none"> • A pilot hires or borrows an aircraft from the operator • The operator hires or otherwise engages a pilot

- An LoA identifies a “Responsible Person”, or equivalent, who is responsible for ensuring that the terms of the LoA are complied with. That person may authorise pilots to operate under the LoA as long as they meet the conditions specified
- The LoA is also specific to individual aircraft listed by serial number and registration. An aircraft may have multiple operators, each with their own LoA
- In the simple example of a private aircraft owner (or trust beneficiary), who is also the operator and pilot, he or she will apply for an LoA for their aircraft naming themselves as the Responsible Person. The LoA will permit them to authorise other pilots to fly the aircraft under P-RNAV, subject to the training and operating requirements specified
- In the case of a Company, Group or Club aircraft, the organisation will be the operator and nominate a responsible person. It would be possible in principle, although perhaps impractical, for a pilot to apply for an LoA, in their personal capacity, for a 3rd party aircraft they have access to

• Although the “Responsible Person” authorises pilots to operate under the LoA, a pilot in command is also responsible for ensuring that they are personally qualified and that an aircraft is suitably equipped, operated and authorised for any flight they undertake

1. RNAV and RNP theory
 - a. Introduction
 - b. The Path-Terminator
 - c. RNAV procedure design
 - d. RNP principles
 - e. RNAV and RNP applications
2. GPS Navigators and their application to RNAV
 - a. The GPS system
 - b. Databases and Coding
 - c. Procedures
 - d. Error detection and warnings
3. P-RNAV Terminal Procedures
 - a. P-RNAV requirements and approvals
 - b. P-RNAV training topics**
 - c. P-RNAV operations
4. RNAV(GPS) Approach Procedures
 - a. GPS procedure types
 - b. GPS approach requirements and approvals
 - c. GPS approach operations
5. Avionics training
6. Simulator and/or Flight training

Summary of P-RNAV pilot training requirements

Complies with JAA TGL10, FAA AC90-96A and UK CAA FODCOM 04/2008



- The table below is a synthesis of training topics in the JAA, FAA and CAA source documents and should comply with all 3
- The rest of this section includes P-RNAV topics that do not fit elsewhere in the manual

T: Theory training requiring study of this manual

A: Avionics training, supported by sections 2 and 5 of this manual

F: Flight and/or Simulator training, see syllabus in section 6

T	A	F	Topic	Comment
✓			General RNAV theory - differences between B-RNAV, P-RNAV and RNP-RNAV - meaning of RNP/ANP - limitations of RNAV - GPS concepts and limitations	Topics are fully covered by this manual - see section 1 - see section 1 - see sections 1 and 2 - see section 2a and 2b
✓			P-RNAV theory - RNP-1 definition as it relates to P-RNAV requirements - airspace where P-RNAV is required - changes to charting and documents to reflect P-RNAV - required navigation equipment for flight in P-RNAV airspace	Topics are fully covered by this manual - see section 1 - see section 3b (this section) - see section 3b (this section) - see section 3a
✓			Charting, database and avionics topics - RNAV path terminator concepts - Waypoint naming concepts - the 'CF' path terminator - the 'TF' path terminator - fly-by and fly-over waypoints	Topics are fully covered by this manual - see section 1 - see section 2b - see section 1 - see section 1 - see section 1
✓		✓	Operational procedures and practices - Normal procedures (TGL10.2) - Contingency procedures (TGL10.3)	Topics are fully covered by this manual - see section 3c - see section 3c
✓	✓	✓	Use of RNAV Equipment - retrieving a procedure from the database - briefing the procedure, comparing it with the charted procedure - action to be taken if discrepancies are noted - sensor management - tactically modifying the flight plan	Topics are covered but not in full, refer to GPS receiver User Manual - see section 2c and sections 5 & 6 - see sections 2 and 3c - see sections 2 and 3c - see section 2 - see sections 5 & 6
		✓	Flying P-RNAV procedures - LNAV and associated lateral control techniques, - VNAV and vertical control techniques, - use of automatic pilot and flight director - implications of system malfunctions not RNAV related	See section 6 for a recommended syllabus for flight/simulator training to meet these requirements

Additional P-RNAV theory topics

1. Airspace where P-RNAV is required

- P-RNAV applies to the airspace of the 42 countries which are members of the European Civil Aviation Conference (ECAC)
- The implementation of P-RNAV has been underway since 2004; the process has accelerated recently and many countries will have some P-RNAV procedures by the end of 2008
- P-RNAV applies to terminal procedures, although this scope may be extended (eg. the current proposals for P-RNAV transit routes in the London TMA). Currently, there are always conventional alternatives available for aircraft that are not P-RNAV compliant, although such aircraft may experience delays and restrictions within busy TMAs
- In the future, some TMAs may become only accessible to P-RNAV approved aircraft (eg. London)



The 42 countries of the ECAC

<http://www.ecac-ceac.org>



Albania, Armenia, Austria, Azerbaijan, Belgium, Bosnia, Bulgaria, Croatia, Cyprus, Czech Republic, Denmark, Estonia, Finland, France, Georgia, Germany, Greece, Hungary, Iceland, Ireland, Italy, Latvia, Lithuania, Luxembourg, Malta, Moldova, Monaco, Netherlands, Norway, Poland, Portugal, Romania, Serbia, Slovakia, Slovenia, Spain, Sweden, Switzerland, Macedonia, Turkey, Ukraine, UK

AICs relating to the planning and implementation status of P-RNAV are available in the ECACNAV website

<http://www.ecacnav.com/content.asp?CatID=207>

Example: current AIC list (last updated 4 September 2007)

AUSTRIA AIC A9/03	LITHUANIA AIC09/06
BELGIUM AIC Nr.05/2006	MALTA AIC A05/03
CROATIA AIC A01/07	NORWAY AIC 01/04
CYPRUS AIC A05/06	THE NETHERLANDS AIC-A 05/06
CZECH REPUBLIC AIC A8/06	POLAND AIC A02/07
DENMARK A20/03	PORTUGAL AIC 001-2007
DENMARK SUPPLEMENT AIC	ROMANIA AIC A01/05
ESTONIA AIC A5/06	SERBIA & MONTENEGRO AIC A6/07
FINLAND AIC A16/2001	SLOVAK REPUBLIC AIC A-9-2003
FRANCE AIC A19/07	SLOVENIA AIC A02/2006
GERMANY AIC IFR 3	SPAIN AIP GEN 1.5-1
GREECE AIC A2/06	SWEDEN AIC A 9/2006
HUNGARY AIC 04/07	SWITZERLAND AIC A019/07
IRELAND AIC Nr.01/07	TURKEY AIC 05/03
ITALY AIC A 3/2004	UNITED KINGDOM AIC 125/2006
LATVIA AIC A01/04	

P-RNAV AIC example

Extract, full document available at <http://www.ecacnav.com/content.asp?CatID=207>



BUNDESREPUBLIK DEUTSCHLAND FEDERAL REPUBLIC OF GERMANY

DFS Deutsche Flugsicherung GmbH (German Air Navigation Services)
Büro der Nachrichten für Luftfahrer (Aeronautical Publication Agency)
Am DFS-Campus 10 · 63225 Langen · Germany
Tel. + 49 6103 707 - 12 71/1272 · Fax + 49 6103 707 - 12 96
www.dfs-aviationshop.de · e-mail: buero.nfl@dfs.de

AIC IFR

AIC IFR 3
15 MAR 07

OPERATION OF PRECISION RNAV (P-RNAV) AIRBORNE EQUIPMENT IN THE TERMINAL AIRSPACE OF GERMANY

3. TERMINAL AREA NAVIGATION APPLICATION PLANNING FOR P-RNAV

3.1 In line with the ECAC-wide agreement, Germany will introduce P-RNAV approval requirements in terminal airspace after successful completion of a safety assessment in the third quarter of 2007. P-RNAV procedures will be implemented in two steps.

3.1.1 Step 1

RNAV terminal area procedures which are published as GPS/FMS RNAV transition to final approach (overlay to radar vector pattern) will, after a new publication, require P-RNAV approval.

3.1.2 Step 2

Standard instrument departure routes using B-RNAV route segments will, after a new publication, require P-RNAV approval.

3.2 Aircraft operation on such P-RNAV terminal area procedures shall be approved in accordance with the relevant JAA Temporary Guidance Leaflet No. 10 (TGL 10 Rev. 1): "Airworthiness and Operational Approval for Precision RNAV Operations in Designated European Airspace", or equivalent.

3.3 Some means of accessing airspace/airports served by P-RNAV designated procedures will continue to be provided by the retention of a limited number of conventional procedures, supplemented by the use of radar vectors. This provision will allow non-approved aircraft to continue to operate routinely into and out of the affected airports. However, such non-P-RNAV aircraft operations may incur delays and/or extended routings during peak periods.

3.4 RNAV (GNSS) non-precision approach procedures based on JAA TGL 3 REV. 1 remain unchanged, since JAA TGL 10 REV. 1 excludes the final approach phase.

Note that current RNAV procedures will be 'upgraded' to require P-RNAV. The only change to the procedure chart may be a small "P-RNAV Approval Required" note

Note the availability of non-RNAV alternatives, but also the caveat on delays & routing

Additional P-RNAV theory topics

2. Changes to charting and documents to reflect P-RNAV

- P-RNAV requirements are published in AIS documents, and in products from commercial suppliers like Jeppesen
- The ATC section of the Jeppesen Airway Manual describes current P-RNAV requirements and status:
 - in the “Air Traffic Control Europe” sub-section, for Europe overall
 - in the “State Rules and Procedures” sub-sections, for individual countries
- “RNAV” is a generic label used in procedure chart titles and names. Specific RNAV requirements, such as P-RNAV, are noted in the chart text

LEBL/BCN
BARCELONA

ATIS 118.65 Apt Elev 14' Alt Set: hPa Trans level: By ATC Trans alt: 6000'

JEPPESEN

16 NOV 07 (10-2) Eff 22 Nov

BARCELONA, SPAIN

RNAV STAR

BISBA TWO YANKEE (BISBA 2Y) [BISB2Y]

RWYS 25L/R RNAV ARRIVAL

RNAV (DME/DME)

P-RNAV APPROVAL REQUIRED

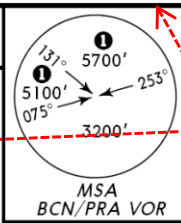

Chart otherwise uses 'generic' RNAV titles

P-RNAV requirement noted in small chart text

- A pilot needs to study the Jepp manual text pages in detail to be sure of all the conditions for RNAV operations. In the example below, EHAM Schiphol’s RNAV procedure charts note a B-RNAV requirement, but the Arrival text pages also describe conditions under which P-RNAV is required

Charts note a B-RNAV requirement

EHAM/AMS
SCHIPHOL

D-ATIS 108.4
132.97 Apt Elev -11'

JEPPESEN

21 MAR 08 (10-2A) Eff 21 Mar

AMSTERDAM, NETHERLANDS

STAR

ARRIVALS

FROM SOUTH

B-RNAV EQUIPMENT MANDATORY

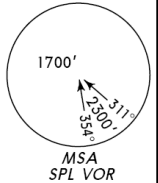

Text pages note a P-RNAV requirement for night arrivals

EHAM/AMS
SCHIPHOL

D-ATIS 108.4
132.97 Apt Elev -11'

JEPPESEN

29 FEB 08 (10-1P4) Eff 13 Mar

AMSTERDAM, NETHERLANDS

AIRPORT BRIEFING

2. ARRIVAL

2.1.4. RNAV PROCEDURES

2.1.4.1. DURING NIGHT

In order to enable their pilots to accept the RNAV transitions, operators of ACFT arriving during NIGHT must hold a P-RNAV operations approval issued by their state, or a temporary exemption issued by CAA Netherlands.

Additional P-RNAV theory topics

3. Flight Plan filing and RNAV

- Within ECAC airspace, the rules for Flight Plan filing relating to an aircraft's RNAV capability differ slightly from the ICAO standard
- The ECAC rules for item 10 (Equipment) of the ICAO FPL form are:
 - that B-RNAV equipment shall form part of the standard equipment, indicated through the use of the letter S in item 10
 - the letter R is also inserted in item 10, in conjunction with the letter S, to indicate B-RNAV compliance
 - the letter P is also inserted in item 10, in conjunction with the letters R and S, to indicate P-RNAV compliance

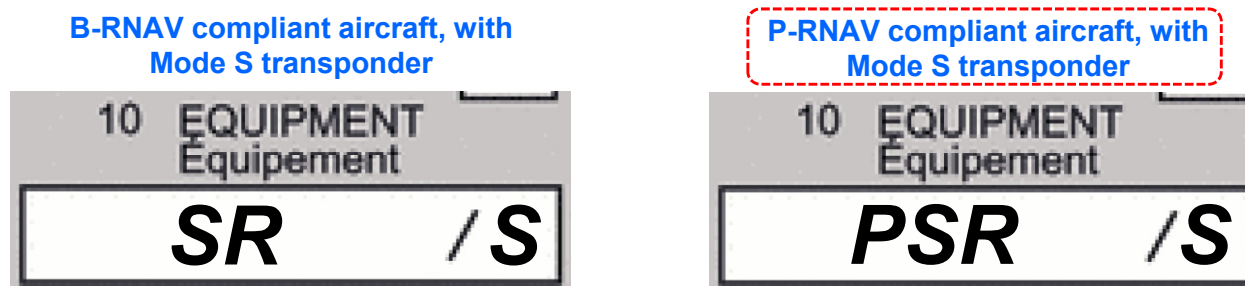

- An aircraft operating under an exemption from RNAV requirements shall indicate this in Item 18 of the FPL with the entry "STS/NONRNAV". These are usually only State aircraft



1. RNAV and RNP theory
 - a. Introduction
 - b. The Path-Terminator
 - c. RNAV procedure design
 - d. RNP principles
 - e. RNAV and RNP applications
2. GPS Navigators and their application to RNAV
 - a. The GPS system
 - b. Databases and Coding
 - c. Procedures
 - d. Error detection and warnings
3. P-RNAV Terminal Procedures
 - a. P-RNAV requirements and approvals
 - b. P-RNAV training topics
 - c. P-RNAV operations**
4. RNAV(GPS) Approach Procedures
 - a. GPS procedure types
 - b. GPS approach requirements and approvals
 - c. GPS approach operations
5. Avionics training
6. Simulator and/or Flight training

P-RNAV Operating Procedures

- TGL 10 Section 10 has guidelines for P-RNAV operating procedures that pilots should be trained in and which should be included in the operations manual or “extended checklist” submitted as part of a P-RNAV LoA application
- The FAA and UK CAA P-RNAV requirements are based on these TGL10 guidelines and ICAO’s European RNAV guidance document

JAA TGL10

JAA Administrative & Guidance Material
Section One: General Part 3: Temporary Guidance Leaflets

LEAFLET NO 10 Rev 1: AIRWORTHINESS AND OPERATIONAL APPROVAL FOR PRECISION RNAV OPERATIONS IN DESIGNATED EUROPEAN AIRSPACE

This leaflet provides guidance material for the approval of aircraft and operations in the European region where Precision Area Navigation (P-RNAV) is required. It relates to the implementation of air navigation within the context of the European Air Traffic Management Programme (EATMP) and should be read in conjunction with EUROCONTROL document 001-2012, Area Navigation Equipment Operational Requirements and Functional Requirements.

TABLE OF CONTENTS

- 1. INTRODUCTION
- 2. PURPOSE
- 3. SCOPE
- 4. REFERENCE DOCUMENTS
- 5. RELATED DOCUMENTS
- 6. ASSUMPTIONS
- 7. SYSTEM DESCRIPTION
- 8. AIRWORTHINESS CERTIFICATION OBJECTIVES FOR RNAV SYSTEMS
- 9. FUNCTIONAL CRITERIA
- 10. ACCEPTABLE MEASURES OF AIRWORTHINESS COMPLIANCE
- 11. OPERATIONAL CRITERIA
- 12. APPENDICES

Annex A: Abbreviations
Annex B: Abbreviations
Annex C: Abbreviations
Annex D: Abbreviations



An overall guide to RNAV approvals, it does not detail the TGL10 guidelines but refers to the need for approved operating procedures

Application requires submission of an “Operations Manuals, to include normal procedures, contingency procedures, incident reporting and flight crew training”

FAA’s AC90-96A



Advisory Circular

Subject: APPROVAL OF U.S. OPERATIONS UNDER INSTRUMENT FLIGHT RULES IN EUROPEAN AIRSPACE DESIGNATED FOR RNAV AREA NAVIGATION (P-RNAV) AND PRECISION AREA NAVIGATION (P-RNAV)

1. PURPOSE

a. This advisory circular (AC) provides operational approval and aeronautical guidance material regarding Area Navigation (RNAV) operations in the operations of U.S.-registered civil aircraft operating in RNAV Area Navigation (RNAV) in European Airspace. Note the P-RNAV operational and approval requirements are more stringent than those for RNAV operations in European RNAV airspace.

b. This AC is used for guidance purposes and to outline a method of compliance with European requirements. In lieu of following the method outlined herein, operators may elect to follow an alternative method, provided the alternative method is also found to be acceptable to the FAA. Operators are encouraged to contact the FAA for more information on alternative methods of compliance.

c. The guidance material is applicable to P-RNAV and RNAV operations in European airspace where appropriate. For the purposes of this AC, RNAV procedures apply to en route and arrival instrument operations. P-RNAV procedures are expected to apply to operations including departures, arrivals, and approaches up to the start of the final approach fix (FAF). For the instrument final approach holding pattern to be flown with conventional procedures. For P-RNAV operations to include departures, arrivals, and approaches up to the FAF, will ensure that aircraft comply with the P-RNAV accuracy requirements.

d. European Regional Supplementary Procedures for RNAV and P-RNAV are contained in International Civil Aviation Organization (ICAO) Doc 7030, Study of Air, Sea, and Land Traffic Services and Search and Rescue. The implementation date for P-RNAV will be determined as published in Notices to Airmen (NOTAMS) and Aeronautical Information Publications (AIP). ICAO Doc 7030 also requires the State of Aircraft Registry or State of the Operator to verify compliance of the Air Operator Certificate holder.

P-RNAV operating procedures are detailed in Appendix 2 Section 3. This is similar to TGL10 section 10, with some additional detail and notes

UK CAA’s FODCOM 04/2008 and CA4045

SAFETY REGULATORY DIVISION
FLIGHT OPERATIONS
DIVISION COMMUNICATION

04/2008

Applicability: All AOC Holders

AREA NAVIGATION (RNAV) - CAA GUIDANCE MATERIAL

1. Introduction

1.1. It is noted that there have been a number of developments in the use of aircraft RNAV systems. In particular, the use of RNAV systems for operations in the designated European Airspace. The CAA has published guidance material for operators regarding P-RNAV. This guidance was published in FODCOM 03/2007.

1.2. The purpose of this FODCOM is to confirm that the operational and approval requirements for RNAV operations and to update the operational and approval requirements for RNAV operations and to update the operational and approval requirements for RNAV operations and to update the operational and approval requirements for RNAV operations.

2. Issue

2.1. This document provides guidance on flight crew training, operational issues and operational approval requirements for RNAV operations. It provides a clear statement of the terminology related to RNAV, it addresses the use of RNAV systems, the use of RNAV systems and the use of RNAV systems and the use of RNAV systems.

2.2. The guidance is attached to this FODCOM (Appendices A, B, C and D) and in the course will be published on the CAA website to enable the information to be updated as required.

3. Recommendations

3.1. It is recommended that operators wishing to conduct any RNAV operations, including managed non-precision approach procedures:

- review current RNAV procedures and training requirements, together with their operations manual and other guidance, to ensure that they conform to the advice contained in the guidance material; and
- follow the guidelines contained in the guidance material when developing procedures and training requirements, and when developing operation manual and other guidance.

4. Sources

4.1. Any queries as a result of this FODCOM should be addressed to head of Flight Operations Policy Department at the following e-mail address: FOP.ASM@caa.gov.uk

4.2. February 2008

Approval of new FODCOMs are added to ensure that there are no gaps in the provision of operational guidance material. Operators who wish to ensure that their operations manual and other guidance material is up to date should refer to the information on the CAA website at www.caa.gov.uk for more information.

Review FODCOM January 2009

UK Civil Aviation Authority

AREA NAVIGATION APPROVALS INCLUDING P-RNAV, RNAV APPROACH AND GROSS APPROACH OPERATIONS

APPLICATION FOR AN RNAV OPERATIONAL APPROVAL/RENEWAL

Please complete the form in BLOCK CAPITALS using black ink and use the following guidance.

This form is designed to collect all the required information from those operators requiring Precision Area Navigation (P-RNAV), RNAV Approach or GROSS approach operations approval. Sections 1 and 2 should be completed in all cases. Completed forms should be submitted to the Flight Operations Policy (Commercial) Section of the Safety Regulation Group at the address listed in the Notes for Completion.

Applicants are strongly advised to read the Notes for Completion before completing the form.

Section 1 Page 1 Operational Approval Details Completion mandatory

Section 2 Page 2 RNAV Operational Approvals Completion mandatory

Section 3 Page 3 Signatures Block/Notes Completion mandatory

Section 4 Page 4 Form Details Communication Sheet

SECTION 1: OPERATIONAL APPROVAL DETAILS

APPLICANT DETAILS - required for all Approval requests

1. Please give the official name and business or trading name(s), address, mailing address, e-mail address and contact number/number numbers of the applicant. (Use reverse)

APPLICANT DETAILS - required for all Approval requests

2. Applicant (operator name, manufacturer/serial number(s), registration mark(s), mode 'S' address (code(s))

Applicant Type	Applicant Name	Manufacturer/Serial Number	Registration	Mode 'S' Code (hex)

(Use continuation sheet provided on page 6, if necessary)

Form CA 4045 issue 1 (2007) Page 1 of 6



➡ The 4 ‘guideline’ pages that follow are a synthesis of the TGL10 and AC90-96A material, omitting items that are not relevant to a single-pilot aircraft. LoA applicants should also refer to the original documents

Pre-flight Planning

1. Check charts and NOTAMS to confirm availability of the navigation infrastructure as required for the flight, including any non-RNAV contingencies
2. Check that the aircraft navigation equipment needed for the route to be flown is compliant and serviceable, including AIP information on whether dual P-RNAV systems are required
3. Check the GPS database coverage and validity is suitable for the intended flight and, in particular, that the terminal procedures for the departure, arrival and alternate airfields are available
4. Check that RAIM is predicted to be available for the route and time of flight using the AUGUR tool (<http://www.augur.ecacnav.com>) up to 24hrs in advance of the flight
5. Note that some P-RNAV procedures require minimum speeds that some piston aircraft can not comply with. Check procedure charts and be prepared to advise ATC of non-compliance and best speed attainable

Prior to Departure

1. Confirm the navigation database is current
2. Receive ATC clearance, including P-RNAV SID designator
3. Load the SID procedure into the GPS flight plan, and complete the enroute flight plan
4. Check the GPS SID procedure against the paper chart, using the map display (as a minimum) or by confirming the waypoint sequence, track angles, distances and fly-by vs fly-over waypoints. A procedure shall not be used if any discrepancy is found
5. Prior to commencing take off, verify the aircraft's GPS position is available and accurate
6. During the procedure, monitor the GPS navigation by crosschecking with conventional navigation aids

Note that the manual entry of waypoints or modification of a P-RNAV procedure is not permitted. However, the pilot must be able to react promptly to ATC route modifications in the form of 'direct to' clearances, by inserting of waypoints into the flight plan from the database if required

Arrival

1. Prior to the start of the procedure, verify that the correct terminal procedure has been loaded
2. Check the loaded procedure against the paper chart, using the map display (as a minimum) or by confirming the waypoint sequence, track angles, distances and fly-by vs fly-over waypoints. A procedure shall not be used if any discrepancy is found
3. Prepare to revert to a conventional arrival procedure if required as a contingency
4. Monitor the GPS navigation by crosschecking with conventional navigation aids, particularly the gross error check with respect to a published VOR/DME fix at the start of a procedure, if available

Notes:

If a GPS integrity alarm is received, a conventional procedure must be flown

The manual entry of waypoints or modification of a P-RNAV procedure is not permitted. However, the pilot must be able to react promptly to ATC route modifications in the form of 'direct to' clearances, by inserting of waypoints into the flight plan from the database if required

All published altitude and speed constraints must be observed

Contingency Procedures

The operator will need to develop contingency procedures to address cautions and warnings for the following conditions:

- Failure of the RNAV system components including, those affecting flight technical error (e.g. failures of the flight director or automatic pilot)
- Failure of the navigation sensors or the loss of RAIM, which constitutes a loss of GPS P-RNAV capability

The pilot must notify ATC of any loss of the P-RNAV capability, together with the proposed course of action

The pilot should continue with the P-RNAV procedure in accordance with the published lost communication procedure in the event of communications failure

The pilot should navigate using an alternative means of navigation which doesn't need to be RNAV

Incident Reporting

Report significant incidents associated with the operation of the aircraft which affect or could affect the safety of P-RNAV operations. Specific examples may include:

- GPS system malfunctions during P-RNAV operations
- Significant navigation errors attributed to incorrect data or a navigation database coding error

Errors or discrepancies with Jeppesen database products should be reported to the contact address at <http://www.jeppesen.com> ...Customer Support...Navigation Data Support

Extracts from the ICAO European RNAV Guidance Material, 5th edition available at http://www.ecacnav.com/Document_Library

(with bold emphasis added)

A synthesis of the items from this document is available in the Jeppesen Airway Manual ATC section, 'Procedures For Area Navigation (RNAV) Operations – Europe' sub-section



Radio Communications and ATC Procedures

The RNAV contingency procedures related to the carriage and operation of B-RNAV equipment, is equally applied to the failure and degradations, in flight, of P-RNAV systems. The following provisions refer

"When an aircraft cannot meet the requirements for either P-RNAV or B-RNAV, as required by the RNAV ATS route or procedure, as a result of a failure or degradation of the RNAV system, a revised clearance shall be requested by the pilot."

The RNAV contingency RTF Phraseology is as follows: **"Unable RNAV due equipment"**

With respect to the degradation/failure in flight, of an RNAV system, while the aircraft is operating on a terminal area procedure requiring the use of RNAV, the following applies:

- a) the aircraft should be provided with radar vectors, until the aircraft is capable of resuming its own navigation; or
- b) the aircraft should be routed by conventional navigation aids, i.e. VOR/DME

The use of radar vectors is considered as a means best suited to resolve such issues in a tactical TMA environment.

Terrain Clearance

The use of RNAV does not affect existing ICAO provisions describing responsibilities with respect to avoidance of terrain. Specifically, unless an IFR aircraft is receiving navigation guidance in the form of radar vectors from ATC, **the pilot remains responsible for avoidance of terrain.**

Developing a P-RNAV “extended checklist” or operations manual

A P-RNAV Operations Manual or ‘extended checklist’ should include 3 elements:

1. The normal checklist items, consistent with the aircraft flight manual
2. The operations manual content for single-pilot IFR
3. The additional content required for P-RNAV

The members’ forum at www.pplir.org, in the “Documents and Tools” section, has 2 editable templates for such a manual

*An FAA Part 91
Operations Manual for
a P-RNAV approved
Cessna 421C*

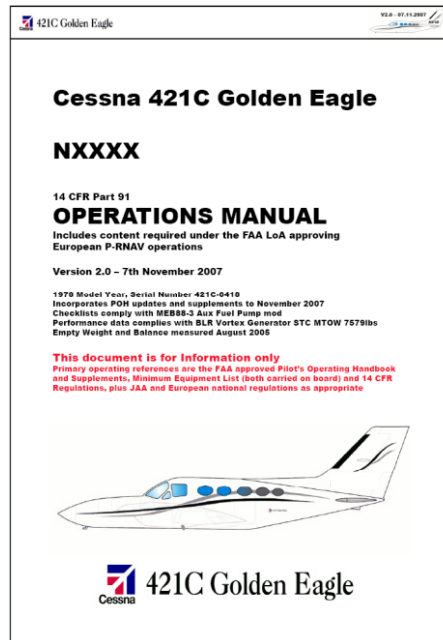

*A template for a Piper
Seneca manual, based on a
UK CAA approved AOC-style
manual used for Instrument
Rating training*



- ➔ • The next 3 pages illustrate the P-RNAV contents and checklist structure used for a Cessna 421 operating under an FAA P-RNAV LoA

P-RNAV extended checklist example: items added to an 'normal' IFR checklist to comply with P-RNAV requirements

Pre-Flight Planning
<ol style="list-style-type: none"> 1. Check AUGUR for RAIM availability, and NOTAMs 2. Check currency and coverage of GNS480 database 3. Check if dual P-RNAV systems are required, and note contingencies in the event of a GNS480 failure
Prior to Departure
<ol style="list-style-type: none"> 1. Verify P-RNAV LoA copies are on board (tech log) 2. Check GNS480 self-test, data currency & coverage (# 1&2) 3. Enter Flight Plan and select Departure Procedure 4. Crosscheck Procedure map display with Jepp paper charts 5. Verify initialisation complete and GPS position available 6. Check RAIM Prediction
GNS480 RAIM Prediction <small>(see Pilot's Guide p19)</small>
<ol style="list-style-type: none"> 1. Highlight Destination waypoint in Flight Plan screen 2. Press INFO key, then RAIM smart key 3. if required, press the CRSR knob to change the ETA 4. Press MENU/ENTER to compute the RAIM prediction
Departure
<ol style="list-style-type: none"> 1. Perform GPS position check on runway 2. Monitor tracking accuracy on CDI scale (1nm) 3. Crosscheck PRNAV guidance with conventional aids
Arrival
<ol style="list-style-type: none"> 1. Select and load the Arrival Procedure in GNS480 #1 2. Crosscheck Procedure map display with Jepp paper charts 3. Prepare and brief the alternative non-PRNAV procedure 4. Complete gross error check using radio navaids 5. Monitor GNS480 for Loss of Integrity annunciation 6. Monitor tracking accuracy on CDI scale (1nm)

P-RNAV Capability Failure (eg. LOI alert)
<p>Total failure of one GNS480</p> <ol style="list-style-type: none"> 1. Revert to the working GNS480 2. Notify ATC <p style="text-align: center;"><i>In the event of an LOI alert, monitor the GNS480s for 1 minute, then initiate the procedures below</i></p> <p>LOI alert or other loss of P-RNAV capability in GNS480#1</p> <ol style="list-style-type: none"> 1. Cancel cross-link function in GNS480#2 from Flight Plan screen menu 2. If in a procedure requiring dual P-RNAV systems, advise ATC & revert to the alternative procedure 3. Cancel GPS Roll Steer mode if selected 4. Select GNS480#2 as nav source for the MX20 and KMD540 MFDs on the avionics switch panel <p>LOI alert or other loss of P-RNAV capability in GNS480#2</p> <ol style="list-style-type: none"> 1. Continue with GNS480#1 as primary nav source 2. If in a procedure requiring dual P-RNAV systems, advise ATC & revert to the alternative procedure <p>LOI alert or other loss of P-RNAV in both GNS480s</p> <ol style="list-style-type: none"> 1. Select radio navigation aids and CDI source 2. Advise ATC and continue with non-PRNAV procedure or as directed 3. Cancel GPS Roll Steer mode if selected
ICAO Flight Plan Form – Item 10
<p>The ICAO flight plan Item 10 (Equipment) entry for Nxxxx is "PRS/S" designating P-RNAV (and B-RNAV) approval and Mode S</p>
Database Integrity
<p>The GNS480 database is certified by Garmin as conforming to Do200a and ED76. Hence, navigation database integrity checks are not required beyond the validity & cross-check procedures above</p>

Illustration of extended checklist structure (1)

Blue boxes are both P-RNAV and 'conventional' IFR checks

Black header boxes indicate where aircraft-specific normal checklist sections should be inserted

P-RNAV Pre-Flight Planning
<ol style="list-style-type: none"> 1. Check AUGUR for RAIM availability, and NOTAMs 2. Check currency and coverage of GNS480 database 3. Check if dual P-RNAV systems are required, and note contingencies in the event of a GNS480 failure
Before Starting Engines
Prior to P-RNAV Departure
<ol style="list-style-type: none"> 1. Verify P-RNAV LoA copies are on board (tech log) 2. Check GNS480 self-test, data currency & coverage (# 1&2) 3. Enter Flight Plan and select Departure Procedure 4. Crosscheck Procedure map display with Jepp paper charts 5. Verify initialisation complete and GPS position available 6. Check RAIM Prediction
GNS480 RAIM Prediction (see Pilot's Guide p19)
<ol style="list-style-type: none"> 1. Highlight Destination waypoint in Flight Plan screen 2. Press INFO key, then RAIM smart key 3. if required, press the CRSR knob to change the ETA 4. Press MENU/ENTER to compute the RAIM prediction
Starting Engines
Before Taxiing

Before Take-Off
IFR Departure Checks (See PRNAV checks if applicable)
<ol style="list-style-type: none"> 1. Departure Clearance.....RECEIVE 2. Avionics..... SET, check GPS data & RAIM 3. Autopilot switches.....Panel ON but AP Console OFF 4. HSI OBS and HDG..... OBS set, HDG to Runway heading 5. <u>Departing into IMC with OAT <10C</u> Pitot & Stall heat, Prop Deice...ON Windshield Deice.....LOW (HIGH if OAT<-10C) <p><u>Departure Brief</u></p> <p>Climb runway HDG... to xxxx ft or x DME Turn..... Left/right to HDG xxx Intercept..... track X @ facility Y Continue climb to..... xxxx ft</p> <p><u>Engine Failure after take-off Brief</u></p> <p>Decision point, Accel Stop/Go performance Failure in IMC: "step on the bug", feather dead leg</p>
P-RNAV Departure and After Departure
<ol style="list-style-type: none"> 1. Perform GPS position check on runway 2. Monitor tracking accuracy on CDI scale (1nm) 3. Crosscheck PRNAV guidance with conventional aids
Takeoff

Illustration of extended checklist structure (2)

Black header boxes indicate where aircraft-specific normal checklist sections should be inserted

Climb
Establishing Cruise
Enroute Checks
Flight in Icing Conditions
Descent
IFR Arrival Checks (See PRNAV checks if applicable)
<ol style="list-style-type: none"> 1. Radios and GPS..... SET 2. Altitude..... SET QNH, check cleared level 3. Mixtures..... CHECK 4. Fuel..... CHECK MAINS & QUANTITY 5. Ice..... CHECK 6. Seats and belts..... CHECK
P-RNAV Arrival
<ol style="list-style-type: none"> 1. Select and load the Arrival Procedure in GNS480 #1 2. Crosscheck Procedure map display with Jepp paper charts 3. Prepare and brief the alternative non-PRNAV procedure 4. Complete gross error check using radio navaids 5. Monitor GNS480 for Loss of Integrity annunciation 6. Monitor tracking accuracy on CDI scale (1nm)

Blue boxes are both P-RNAV and 'conventional' IFR checks

IFR Initial Approach Checks
<ol style="list-style-type: none"> 1. Lights..... AS REQD 2. Aux Fuel Pumps.....LOW 3. Cabin Pressure..... DIFFERENTIAL NEARING ZERO 4. Yaw Damp..... OFF 5. Throttles.....22" 5. Flaps..... 15°, below 176 KIAS
IFR Final Approach Checks
<ol style="list-style-type: none"> 1. Gear..... DOWN 2. Flaps..... 30° if AP off and below 146 KIAS 3. Ice.....CHECK
IFR 1000' Checks
<ol style="list-style-type: none"> 1. Gear..... 3 GREENS 2. Props.....1800rpm, MAX IF REQD 3. Mixtures.....FULL RICH 4. Cabin Pressure.....ZERO DIFFERENTIAL 5. Ice.....CHECK
VFR Approach and Landing
Go-Around

1. RNAV and RNP theory
 - a. Introduction
 - b. The Path-Terminator
 - c. RNAV procedure design
 - d. RNP principles
 - e. RNAV and RNP applications
2. GPS Navigators and their application to RNAV
 - a. The GPS system
 - b. Databases and Coding
 - c. Procedures
 - d. Error detection and warnings
3. P-RNAV Terminal Procedures
 - a. P-RNAV requirements and approvals
 - b. P-RNAV training topics
 - c. P-RNAV operations
4. RNAV(GPS) Approach Procedures
 - a. GPS procedure types**
 - b. GPS approach requirements and approvals
 - c. GPS approach operations
5. Avionics training
6. Simulator and/or Flight training

Introduction: ICAO definition of approach types

- ICAO annex 10 recognises three classes of instrument approach:

NPA	APV	PA
Non-Precision Approach	Approach with Vertical Guidance	Precision Approach
Based on a navigation system that provides course deviation information, but no glidepath	Based on a navigation system that does not meet the precision approach standards of ICAO Annex 10 but which does provide course <u>and</u> glidepath deviation. Procedures have a DA rather than an MDA.	Based on a navigation system that provides course and glidepath deviation which meets the precision standards of ICAO Annex 10

Examples based on traditional radio aids and radar:

VOR, NDB, LOC, LDA, SRA	LDA with glidepath (an ILS-like installation not meeting PA criteria, eg. because of the localiser offset from the runway)	ILS, MLS, PAR
--------------------------------	--	----------------------

Examples based on RNAV:

<p>RNAV(GPS) or RNAV(GNSS) “Published overlay” or “stand-alone” GPS non-precision approaches, which use LNAV minima</p>	<p>LNAV/VNAV Vertical guidance provided by SBAS-GPS (eg. WAAS) or Baro-VNAV (through approved FMS)</p> <p>LPV Vertical guidance provided by SBAS-GPS (eg. WAAS). Procedure may ‘downgrade’ to LNAV/VNAV minima if satellite signal or runway environment/lighting does not meet LPV criteria</p>	<p>GLS GNSS Landing System: precision approach based on GPS with GBAS (eg. LAAS) Currently, CAT I procedures have been deployed in limited numbers. CAT II and III applications are being developed.</p>
--	--	---

-  • This manual will only address Non-Precision GPS approaches, since there are currently no procedures with GPS vertical guidance available in Europe

Typical structure of a conventional NPA

Note: this is an illustrative generalisation of a procedure. Always refer to actual charts and chart notes

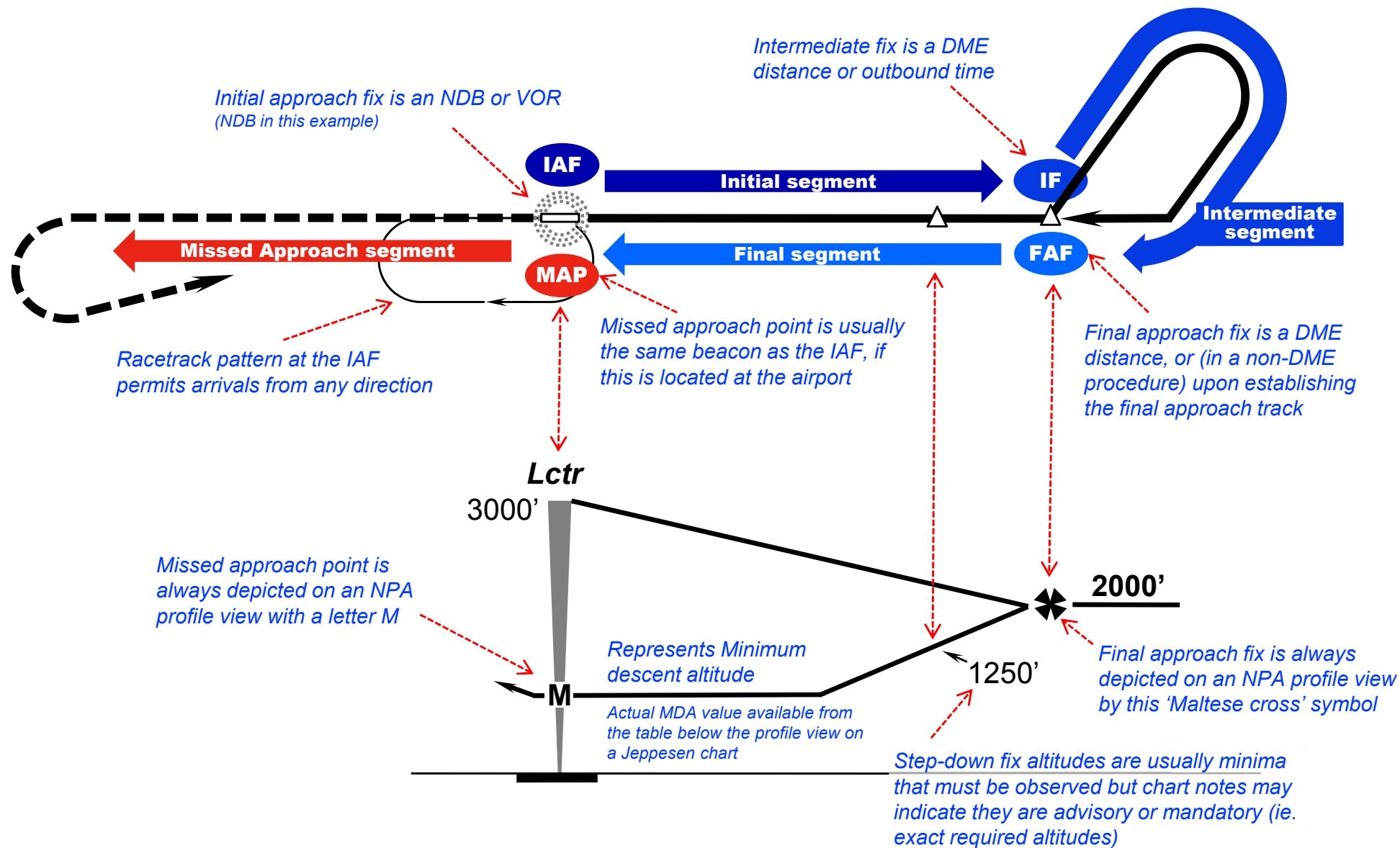

Example of a conventional NPA

EGNH (Blackpool) NDB DME Runway 28

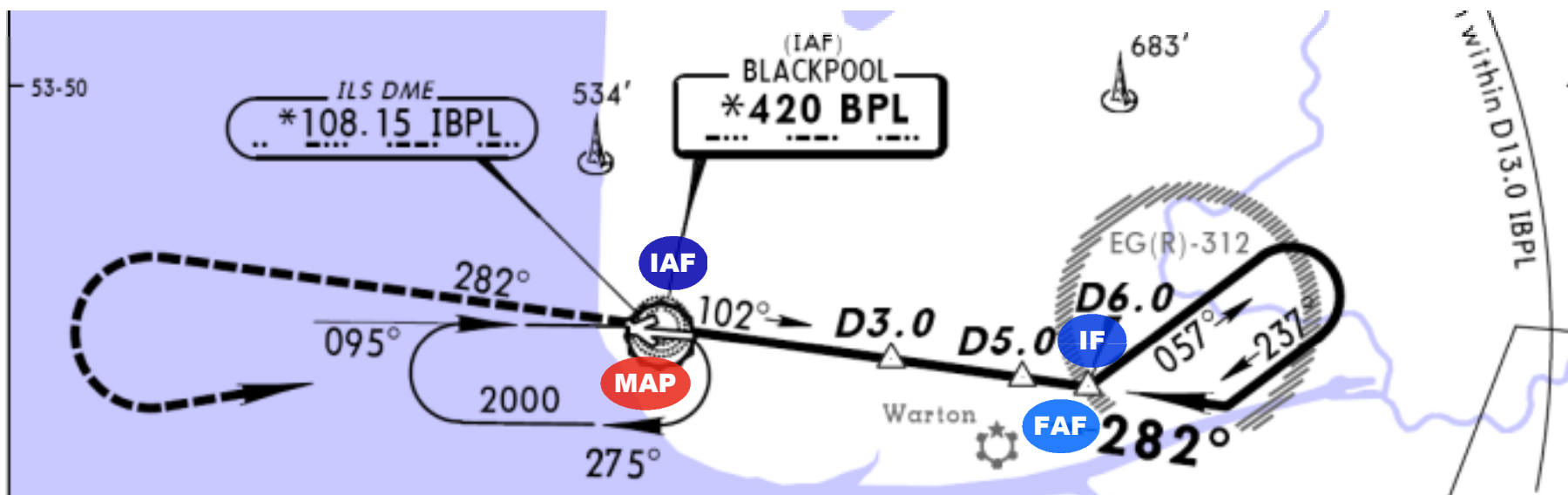

DO NOT USE FOR NAVIGATION

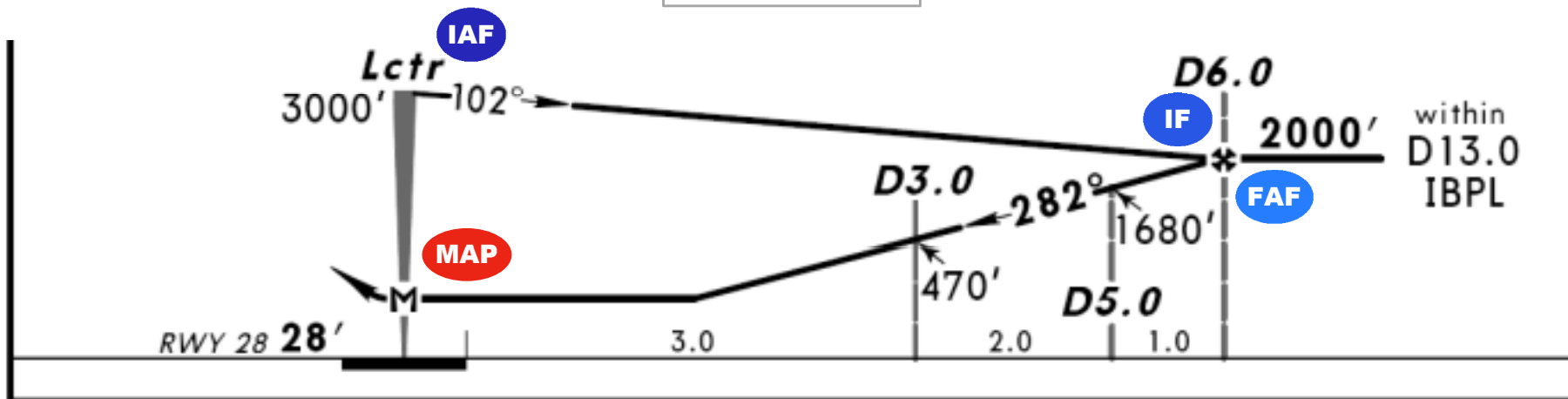

Typical structure of a GPS NPA: the “T-shaped” procedure

Note: this is an illustrative generalisation of a procedure. Always refer to actual charts and chart notes

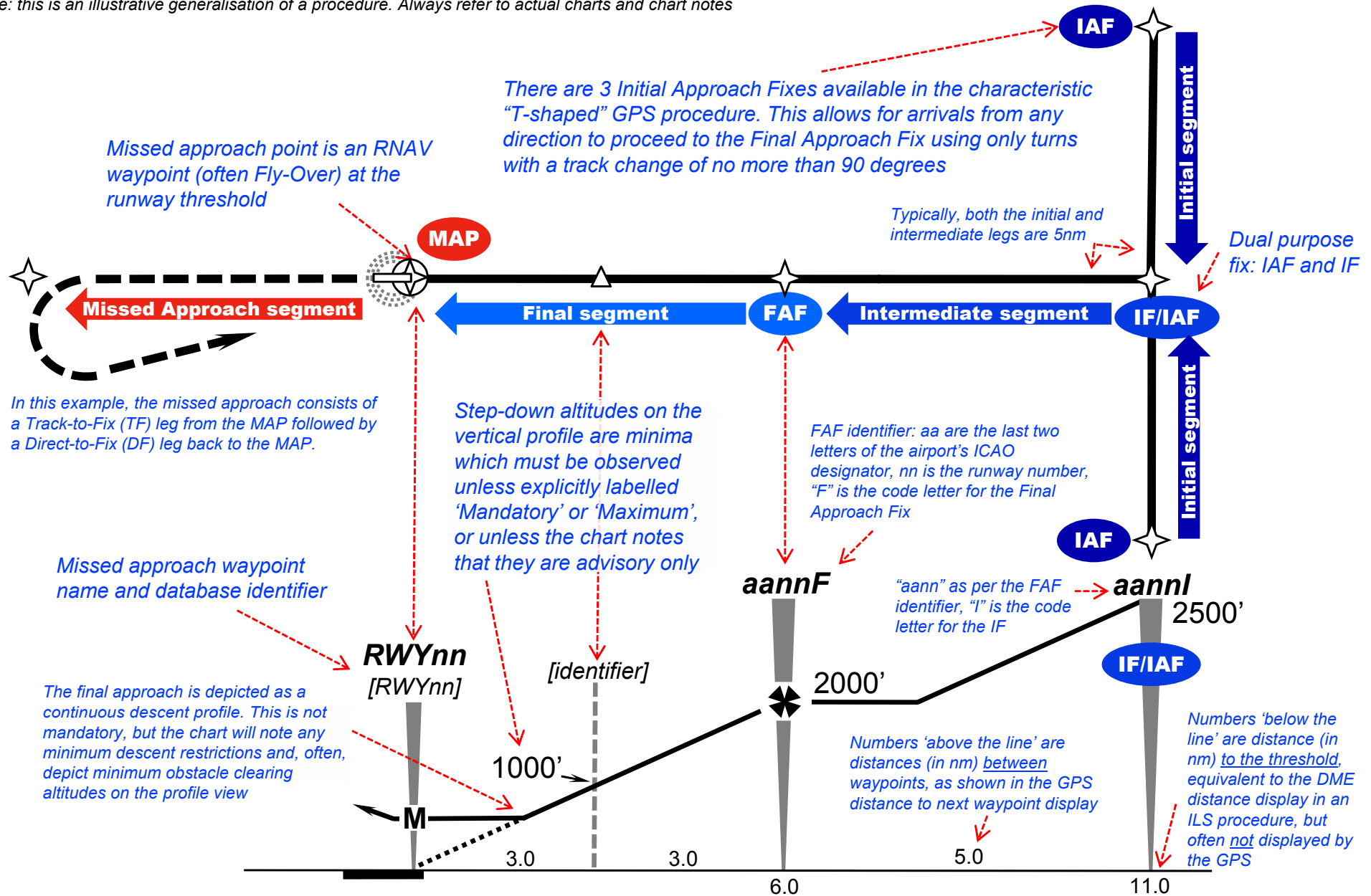

Example of a GPS NPA

EGNH (Blackpool) RNAV(GNSS) Runway 28

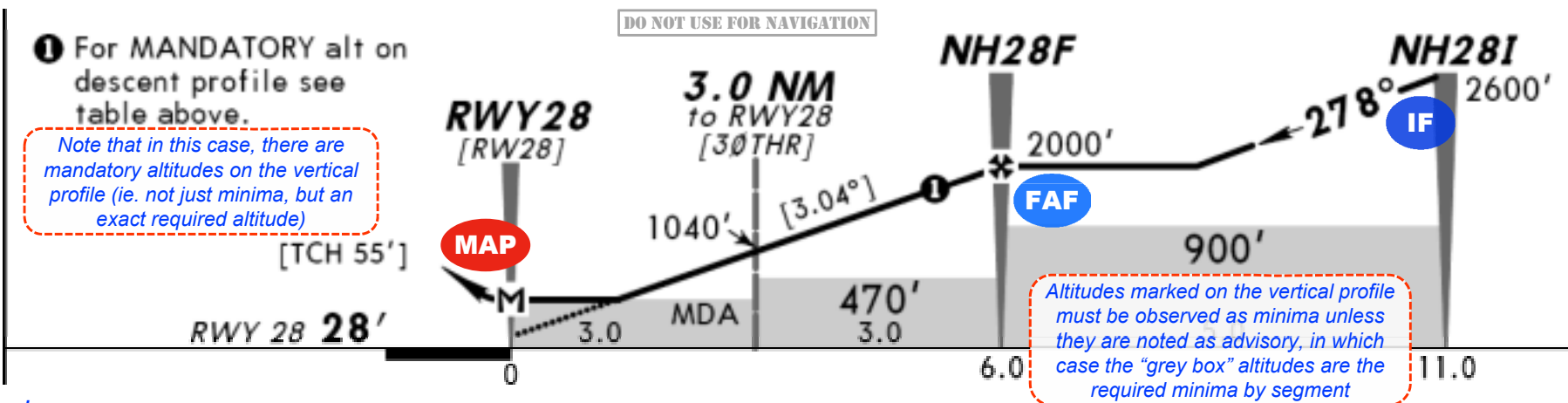

GPS NPA notes (1)

The arrival track to the IF determines which IAF is used in a “T” procedure

- When approaching the procedure area, the aircraft’s arrival track (or magnetic bearing) to the IF determines which IAF should be used

Arrival tracks more than 90 degrees from the final approach should route to the nearest IAF on the crossbar of the T

Arrivals within 90 degrees of the final approach track should route to the dual purpose IF/IAF at the head of the T for a straight-in approach

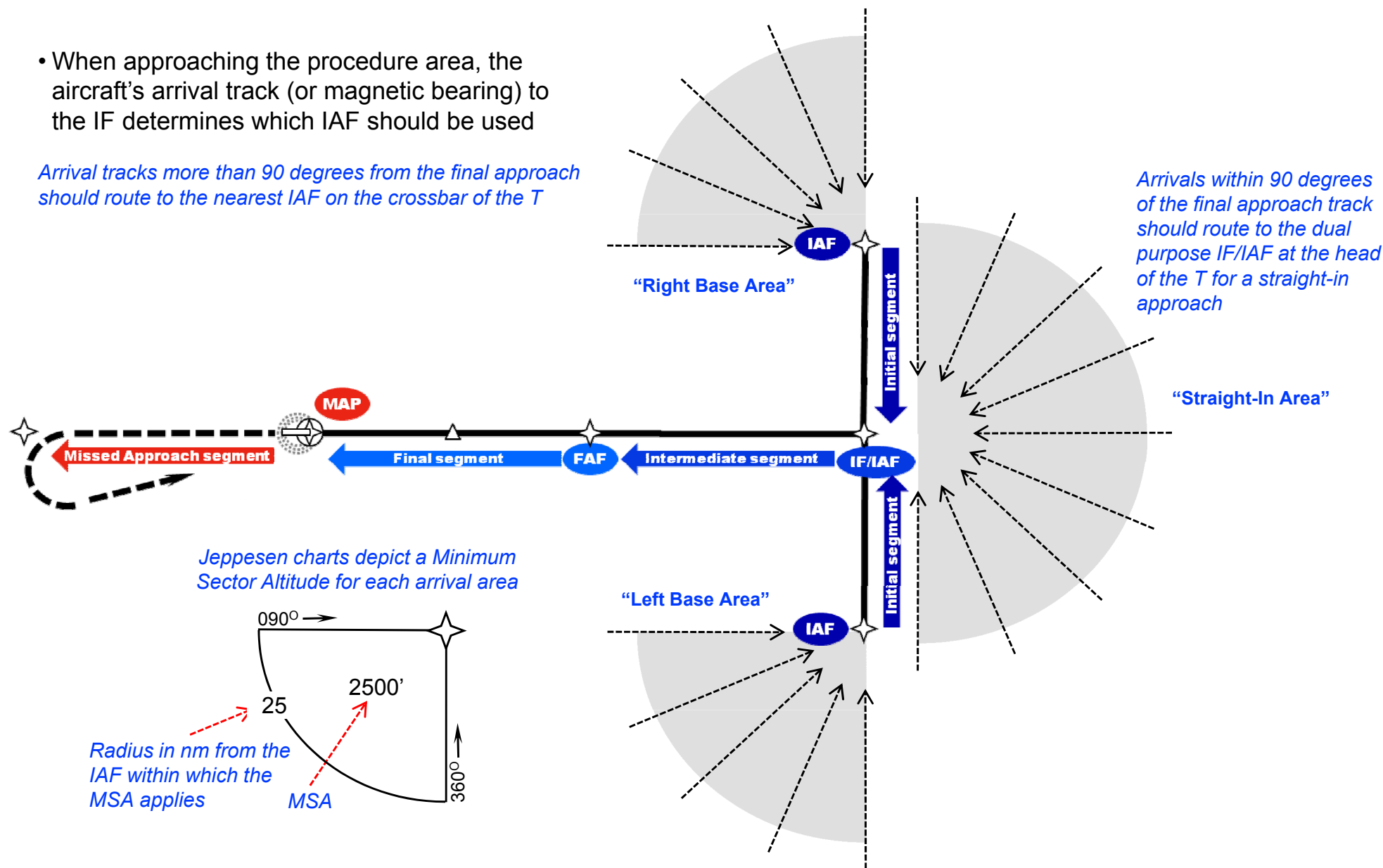

GPS NPA notes (2)

The "T" structure is not used in all GPS NPAs

LFBZ (Biarritz) RNAV(GNSS) Rwy 09

EDDK (Cologne-Bonn) RNAV(GPS) Rwy 32L

Example in which terrain precludes a T-shaped procedure with low-level arrivals from all directions

Example of a larger airport, where the IAF's conform to the structure of standard arrival routes within the TMA rather than a T-shaped GPS NPA

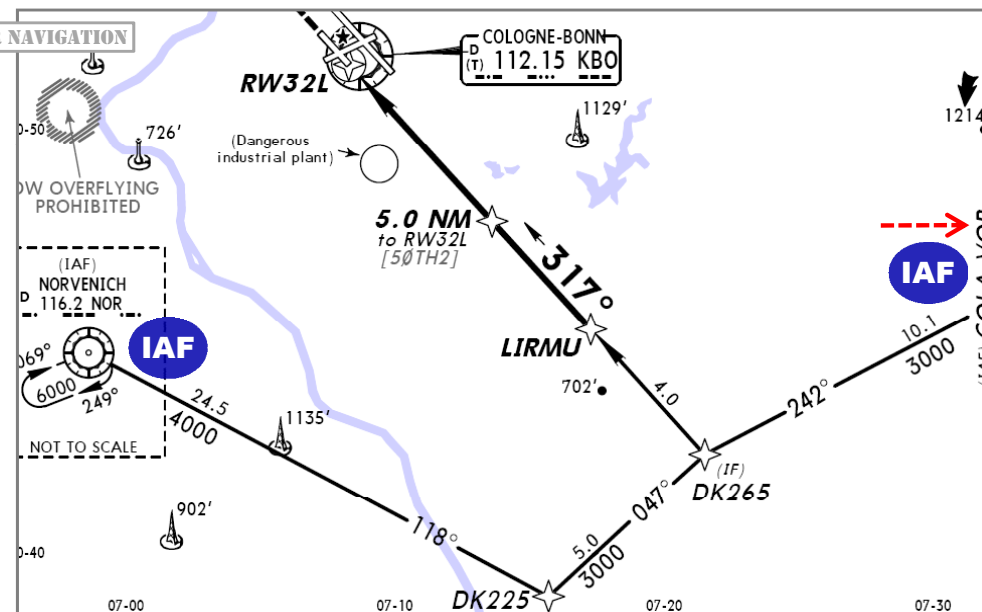
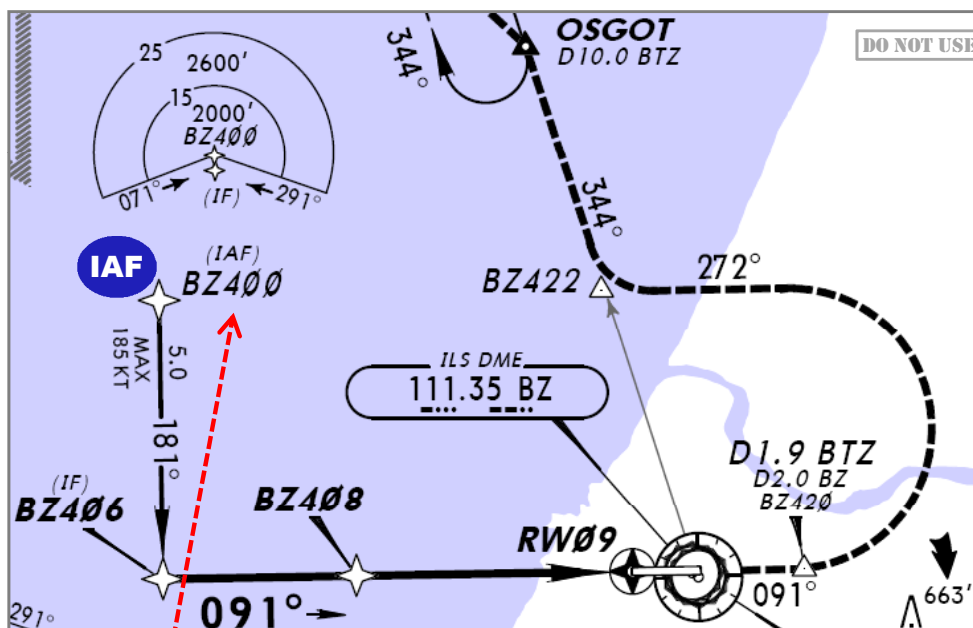

BZ400 is the only IAF; note in this case that arrivals to BZ400 are permitted from an arc of 220 degrees

High terrain means that the MSA for arrivals from the south of Biarritz is 6000', hence the middle and southerly IAFs that would make up a standard T procedure are not available. Southerly arrivals may route via OSGOT to descend and join the procedure at BZ400

At a larger airport like Cologne, pilots may expect a STAR terminating at one of the IAFs (eg. NORVENICH or COLA), or radar vectors to the GPS final approach or to an intermediate waypoint on the GPS NPA

GPS NPA notes (3)

RNAV approach charts may include NPA, APV and PA procedure minima

Example: LONDON, UK
RNAV (GNSS) Rwy 27L

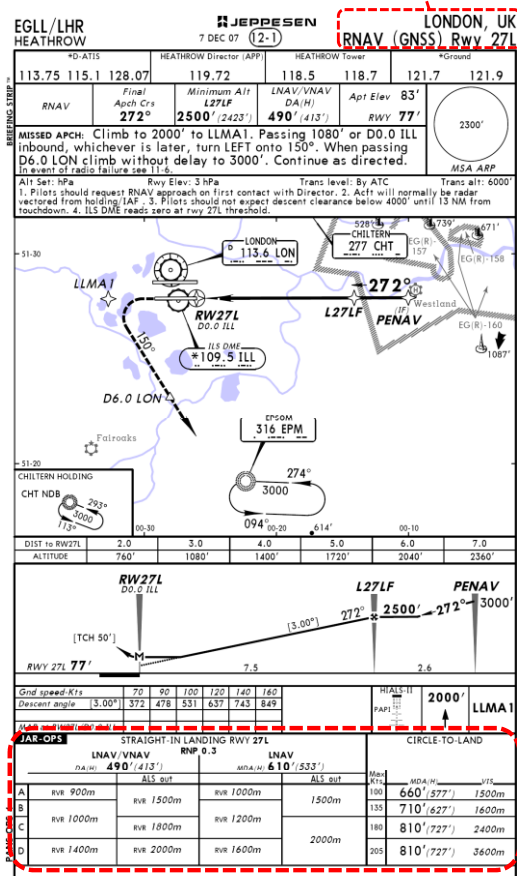

RNAV/VNAV minima apply to an APV procedure (Approach with Vertical guidance) which uses either Baro-Aided VNAV or SBAS (WAAS or EGNOS). Light aircraft avionics do not support Baro-aiding of this kind and EGNOS is not yet available for aviation uses in Europe, hence these minima will not apply to light GA operators

The "RNAV" minima are the correct ones for a GPS Non-Precision Approach

JAR-OPS	STRAIGHT-IN LANDING RWY 27L		CIRCLE-TO-LAND	
	RNAV/VNAV DA(H) 490' (413')	RNP 0.3 ALS out	RNAV MDA(H) 610' (533')	ALS out
A	RVR 900m	RVR 1500m	RVR 1000m	1500m
B	RVR 1000m	RVR 1800m	RVR 1200m	1600m
C	RVR 1400m	RVR 2000m	RVR 1600m	2400m
D			2000m	3600m



DO NOT USE FOR NAVIGATION

Source: Jeppesen

GPS units like the Garmin 430/530 use baro-aiding to improve a position fix when fewer satellites are visible, and can provide advisory VNAV information based on user-defined altitude targets. This should not be confused with the Baro-aided VNAV needed for an APV. In Europe, suitable WAAS-approved GPS installations will be able to provide the synthetic glideslope guidance for APV and LPV procedures when EGNOS is fully operational

1. RNAV and RNP theory
 - a. Introduction
 - b. The Path-Terminator
 - c. RNAV procedure design
 - d. RNP principles
 - e. RNAV and RNP applications
2. GPS Navigators and their application to RNAV
 - a. The GPS system
 - b. Databases and Coding
 - c. Procedures
 - d. Error detection and warnings
3. P-RNAV Terminal Procedures
 - a. P-RNAV requirements and approvals
 - b. P-RNAV training topics
 - c. P-RNAV operations
4. RNAV(GPS) Approach Procedures
 - a. GPS procedure types
 - b. GPS approach requirements and approvals**
 - c. GPS approach operations
5. Avionics training
6. Simulator and/or Flight training

- In general, for private GA operators, GPS Non-Precision Approaches are an additional type of IFR procedure that does not require special authorisation or additional pilot qualifications

	1. Avionics approval	2. Pilot knowledge and training	3. Operations
FAA 	<ul style="list-style-type: none"> • Based on aircraft original equipment: <ul style="list-style-type: none"> – Flight Manual section on GPS equipment must specify that the installation is approved for IFR and GPS approaches • Based on retrofit equipment: <ul style="list-style-type: none"> – Installation must be IFR approved as per AC20-138A – Flight Manual supplement must specify that installation is approved for GPS approaches 	<ul style="list-style-type: none"> • A current FAA Instrument Rating qualifies a pilot to fly GPS NPAs without a requirement for further formal ground or flight training • The FAA recommends that pilots should be familiar with at least the 12 areas of GPS operation listed in AIM section 1-1-19-P, either through training or by practicing in VMC conditions 	<ul style="list-style-type: none"> • 14 CFR Part 91 regulations govern IFR flight for private operators • The Aeronautical Information Manual (AIM) Section 1-1-19 details the requirements for using GPS as a navigation aid in NPAs and other IFR applications • AIM Section 5-4-5 “Instrument Procedure Charts” describes the design of GPS NPAs and the related aircraft and ATC procedures
UK CAA 	<ul style="list-style-type: none"> • Based on aircraft original equipment: <ul style="list-style-type: none"> – Flight Manual section on GPS equipment must specify that the installation is approved for IFR and GPS approaches • Based on retrofit equipment: <ul style="list-style-type: none"> – Installation must be an EASA approved modification and the corresponding Flight Manual supplement must specify that installation is approved for GPS approaches 	<ul style="list-style-type: none"> • A current UK CAA or JAA Instrument rating (or UK IMC Rating) qualifies a pilot to fly GPS NPAs without a requirement for further formal ground or flight training • However, the UK CAA recommends that all pilots undergo training before flying GPS NPAs • CAP773, available at www.caa.co.uk, provides a detailed guide for pilots, instructors and FTOs on suitable training 	<ul style="list-style-type: none"> • AIP Supplement S 11/2008 describes the basic operating requirements for GPS NPAs in UK airspace • CAP 773 has further detail on recommended operating practices specific to GPS NPAs • Although private operators do not need approval for GPS NPAs, the CAA RNAV Approval guidance document, FODCOM 04/2008, is a useful additional source of information

- ➔ • **The key requirement for both N- and G- registered aircraft is that the Flight Manual (or equivalent) permits the GPS installation to be used for standalone GPS NPAs**
- **Section 4c of this document details the required and/or recommended operating procedures for GPS NPAs**

- Some countries do require general aviation pilots to have completed formal training in GPS NPAs, and this requirement may also apply to foreign-registered aircraft operators
- Note that holders of JAA Instrument Ratings are not exempt from any additional national regulations of other JAA countries they fly in
- These national regulations are available in State AIS publications, and are usefully summarised in the Jeppesen Airway Manual ATC Section, under “State Rules and Procedures”

Example: extract from Jeppesen Airway Manual, ATC Section, State Rules and Procedures: Germany

GENERAL REQUIREMENTS FOR PILOT QUALIFICATION

Pilots wishing to carry out GPS stand alone non-precision approaches must have familiarized themselves sufficiently with the basic principles, special features and restrictions of GPS, as well as the handling of the GPS equipment on board the aircraft.

Pilot qualification for the use of the GPS procedures and GPS receivers must be proved. Such proof may be provided, for example, in the form of certificates issued by the equipment manufacturers, IFR flight training centres as well as by flight instructors, authorized trainers and technical experts in possession of an IFR rating, respectively. Proof may be entered in the pilot's logbook.

Example: extract from Jeppesen Airway Manual, ATC Section, State Rules and Procedures: Denmark

Qualification requirements for non-commercial pilots

Pilots wishing to carry out GPS non-precision approaches shall have sufficient theoretical and practical knowledge about the use of navigational equipment based on GPS before this equipment is used.

Documentation for pilot qualification training is to be presented on request and shall be entered in the pilot's logbook or the like.

- ➔ **• PPL/IR Europe recommends that all private pilots complete a suitable course of training before flying GPS Non-Precision Approaches**
- **A logbook endorsement from an instructor or FTO, that this training has been completed, should also qualify the pilot for GPS NPAs in the countries where such training is required**

Summary of GPS NPA pilot training recommendations

• The table below is a synthesis of recommended training topics based on FAA and CAA source documents

T: Theory training requiring study of this manual

A: Avionics training, supported by sections 2 and 5 of this manual

F: Flight and/or Simulator training, see syllabus in section 6

T	A	F	Topic	Comment
✓			General RNAV theory - definition and meaning of RNAV and RNP - limitations of RNAV - GPS concepts and limitations - RAIM	Topics are fully covered by this manual - see section 1 - see sections 1 and 2 - see section 2a and 2b - see section 2d
✓			GPS NPA Theory - GPS NPA procedure design - GPS NPA procedure charts, limitations and minima - required navigation equipment for GPS NPAs	Topics are fully covered by this manual - see section 4a - see section 4a - see section 4b (this section)
✓			Charting, database and avionics topics - RNAV path terminator concepts - fly-by and fly-over waypoints - waypoint naming concepts - coding of GPS overlays and standalone NPAs - use of only current databases & coded procedures; cross-checking	Topics are fully covered by this manual - see section 1 - see section 1 - see section 2b - see section 2c - see section 2b
✓		✓	Operational procedures and practices - Normal procedures - Contingency procedures	Topics are fully covered by this manual - see section 4c - see section 4c
✓	✓	✓	Use of RNAV Equipment - retrieving a procedure from the database - briefing the procedure, comparing it with the charted procedure - action to be taken if discrepancies are noted - sensor management - tactically modifying the flight plan	Topics are covered but not in full, refer to GPS receiver User Manual - see section 2c and sections 5 & 6 - see sections 2 and 3c - see sections 2 and 3c - see section 2 - see sections 5 & 6
		✓	Flying GPS NPA procedures - LNAV, VNAV and associated control techniques, - use of automatic pilot and flight director - missed approach and contingency procedures (eg. loss of RAIM) - ATC procedures	See section 6 for a recommended syllabus for flight/simulator training to meet these requirements

 SUPPLEMENTS TO THE UNITED KINGDOM AIP	S 11/2008	
	Publication Date:	
	24 April	

2 General

2.1 Notified RNAV (GNSS) Instrument Approach Procedures will be available for use by all Instrument and IMC Rated pilots of UK and foreign registered aircraft. Aircraft must have suitably approved equipment.

3 Aircraft Navigation System

3.1 The aircraft navigation system shall include at least one GPS receiver. The navigation system must be approved to conduct:

- (a) RNAV (GNSS) stand-alone approaches¹ or;
- (b) approaches of RNP 0.3 or RNP-RNAV 0.3 type².

3.2 All approved installations must have the appropriate approval for RNAV (GNSS) approach operations entered in the Aircraft Flight Manual (AFM), Pilot Operating Handbook (POH) or equivalent. The navigation system can be as a minimum:

- (a) A system only based on GNSS having at least one GPS receiver qualified to TSO-C129a / ETSO-C129a Class A1 or TSO-C146()/3 / ETSO-C146() Class Gamma and operational class 1, 2 or 3 or;
- (b) a multi-sensor system (eg, Flight Management System) having at least one GPS receiver qualified to TSO-C129() / ETSO -C129() Class B1, C1, B3 or C3 or TSO-C145() / ETSO-C145() class 1, 2 or 3 (with equivalent integration guidance).

3.3 Any operating limitations mentioned in the AFM, concerning use of the navigation system on RNAV (GNSS) approach procedures must be observed.

3.4 Pilots must be able to determine that the on-board aeronautical database and software version in use for the navigation system is valid for the time of flight. The entire approach procedure must be loadable, by name, from the navigation database.

Manually entered and overlay procedures must not be used as the primary reference on any approach, at any time.

4 Pilot Training and Licensing

.....

4.2 CAP 773, Flying RNAV (GNSS) Approaches in General Aviation Aircraft provides guidance to pilots and instructors in the use of GPS for approach operations. This CAP contains technical information on the function of GPS together with equipment requirements, human factors considerations, training and practical guidance for the use of GPS during RNAV (GNSS) approach operations. It also contains guidance for instructors, Flight Training Organisations (FTOs) and Registered Facilities on appropriate training for RNAV (GNSS) approaches. CAP 773 is available on the CAA website and then by following the links Publications; General Aviation.

4.3 A CAA Personnel Licensing Department policy statement entitled, Flight Training and Testing for RNAV (GNSS) Non-Precision Instrument Approaches is available on the CAA website and then by following the links Safety Regulation; Personnel Licensing; What's New?

4.4 CAA Safety Sense Leaflet No.25 (Use of GPS) has been updated to include safety related guidance and information on the use of GPS in IMC and on instrument approaches. The leaflet may be found on the CAA website and then by following the links, Safety Regulation; General Aviation; Safety Sense Leaflets.

AIM Chapter 1: Air Navigation; Section 1: Navigation Aids; Sub-section 19: GPS

d. General Requirements

1. Authorization to conduct any GPS operation under IFR requires that:

- (a) GPS navigation equipment used must be approved in accordance with the requirements specified in Technical Standard Order (TSO) TSO-C129, or equivalent, and the installation must be done in accordance with Advisory Circular AC 20-138, Airworthiness Approval of Global Positioning System (GPS) Navigation Equipment for Use as a VFR and IFR Supplemental Navigation System, or Advisory Circular AC 20-130A, Airworthiness Approval of Navigation or Flight Management Systems Integrating Multiple Navigation Sensors, or equivalent. Equipment approved in accordance with TSO-C115a does not meet the requirements of TSO-C129. Visual flight rules (VFR) and hand-held GPS systems are not authorized for IFR navigation, instrument approaches, or as a principal instrument flight reference. During IFR operations they may be considered only an aid to situational awareness.
- (b) Aircraft using GPS navigation equipment under IFR must be equipped with an approved and operational alternate means of navigation appropriate to the flight. Active monitoring of alternative navigation equipment is not required if the GPS receiver uses RAIM for integrity monitoring. Active monitoring of an alternate means of navigation is required when the RAIM capability of the GPS equipment is lost.
- (c) Procedures must be established for use in the event that the loss of RAIM capability is predicted to occur. In situations where this is encountered, the flight must rely on other approved equipment, delay departure, or cancel the flight.
- (d) The GPS operation must be conducted in accordance with the FAA-approved aircraft flight manual (AFM) or flight manual supplement. Flight crew members must be thoroughly familiar with the particular GPS equipment installed in the aircraft, the receiver operation manual, and the AFM or flight manual supplement. Unlike ILS and VOR, the basic operation, receiver presentation to the pilot, and some capabilities of the equipment can vary greatly. Due to these differences, operation of different brands, or even models of the same brand, of GPS receiver under IFR should not be attempted without thorough study of the operation of that particular receiver and installation. Most receivers have a built-in simulator mode which will allow the pilot to become familiar with operation prior to attempting operation in the aircraft. Using the equipment in flight under VFR conditions prior to attempting IFR operation will allow further familiarization.
- (e) Aircraft navigating by IFR approved GPS are considered to be area navigation (RNAV) aircraft and have special equipment suffixes. File the appropriate equipment suffix in accordance with TBL 5-1-2, on the ATC flight plan. If GPS avionics become inoperative, the pilot should advise ATC and amend the equipment suffix.
- (f) Prior to any GPS IFR operation, the pilot must review appropriate NOTAMs and aeronautical information. (See GPS NOTAMs/Aeronautical Information.)
- (g) Air carrier and commercial operators must meet the appropriate provisions of their approved operations specifications.

AIM Chapter 1: Air Navigation; Section 1: Navigation Aids; Sub-section 19: GPS

p. GPS Familiarization

Pilots should practice GPS approaches under visual meteorological conditions (VMC) until thoroughly proficient with all aspects of their equipment (receiver and installation) prior to attempting flight by IFR in instrument meteorological conditions (IMC). Some of the areas which the pilot should practice are:

1. Utilizing the receiver autonomous integrity monitoring (RAIM) prediction function;
2. Inserting a DP into the flight plan, including setting terminal CDI sensitivity, if required, and the conditions under which terminal RAIM is available for departure (some receivers are not DP or STAR capable);
3. Programming the destination airport;
4. Programming and flying the overlay approaches (especially procedure turns and arcs);
5. Changing to another approach after selecting an approach;
6. Programming and flying "direct" missed approaches;
7. Programming and flying "routed" missed approaches;
8. Entering, flying, and exiting holding patterns, particularly on overlay approaches with a second waypoint in the holding pattern;
9. Programming and flying a "route" from a holding pattern;
10. Programming and flying an approach with radar vectors to the intermediate segment;
11. Indication of the actions required for RAIM failure both before and after the FAWP; and
12. Programming a radial and distance from a VOR (often used in departure instructions).

1. RNAV and RNP theory
 - a. Introduction
 - b. The Path-Terminator
 - c. RNAV procedure design
 - d. RNP principles
 - e. RNAV and RNP applications
2. GPS Navigators and their application to RNAV
 - a. The GPS system
 - b. Databases and Coding
 - c. Procedures
 - d. Error detection and warnings
3. P-RNAV Terminal Procedures
 - a. P-RNAV requirements and approvals
 - b. P-RNAV training topics
 - c. P-RNAV operations
4. RNAV(GPS) Approach Procedures
 - a. GPS procedure types
 - b. GPS approach requirements and approvals
 - c. GPS approach operations**
5. Avionics training
6. Simulator and/or Flight training

Summary of GPS NPA operating procedures

- The table below is a synthesis of operating procedures for GPS NPAs based on FAA and CAA source documents

Phase of Flight	Operating Procedure required or recommended (in addition to conventional IFR procedures and checks)
1. Pre-Flight Planning	<ul style="list-style-type: none"> • IFR approval and serviceability of GPS and alternative navigation equipment • Availability of GPS NPA and alternative conventional procedures • Weather forecasts for destination and alternate. GPS NPA and alternate minima • RAIM prediction • NOTAM check
2. Pre-Flight Checks	<ul style="list-style-type: none"> • GPS database currency and coverage • Check coding of expected GPS NPA procedure against paper charts • GPS receiver self-test, user selectable settings, LOI monitoring • Flight plan entry and RAIM prediction • Requirement to use a database coded procedure for GPS NPAs, without user entry or amendment
3. Pre-Arrival	<ul style="list-style-type: none"> • Selecting and checking the Approach procedure • Determining the appropriate IAF • Activation of the procedure and CDI scaling
4. Flying the GPS NPA procedure	<ul style="list-style-type: none"> • Gross error check approaching the IAF, and check that the GPS is in TERM mode with CDI scaling at 1nm • GPS and Navigation instrument mode selection • Use of the GPS receiver if a hold or vectors to an intermediate waypoint on the NPA are required • Check activation of APP mode and CDI scaling to 0.3nm prior to the FAF
5. Flying the Missed Approach	<ul style="list-style-type: none"> • Activation of the Missed Approach procedure and the need to manually re-initiate waypoint sequencing • Mode selection and pilot actions in non-RNAV missed approach segments
6. ATC communications	<ul style="list-style-type: none"> • Communications during normal procedures • Communications in the event of a GPS navigation failure
7. Contingencies in the event of a GPS navigation failure	<ul style="list-style-type: none"> • Immediate actions • Reverting to alternative procedures



• Each of these procedures is detailed in the following pages

• *This section includes only the key elements needed for GPS NPAs in addition to conventional IFR operating procedures and checks*

GPS NPA operations (1) Pre-Flight Planning

Operating Procedure	Notes and comments
IFR approval and serviceability of GPS and conventional navigation equipment	<ul style="list-style-type: none"> The pilot is responsible for ensuring that the GPS installation is approved for IFR and GPS approaches <ul style="list-style-type: none"> - the aircraft flight manual (or equivalent) is the primary source of this information <i>The operator must ensure that the flight manual and installation is kept current: the GPS manufacturer may, at times, require mandatory software and hardware upgrades, or issue updates to the flight manual</i> Unless a VFR alternate is available, the pilot must also ensure that appropriate conventional navigation equipment is serviceable and IFR-approved
Availability of GPS NPA and alternative non-GPS procedures	<ul style="list-style-type: none"> The pilot should review and brief both the GPS and conventional procedures available at the destination and alternate. This is useful even though a GPS satellite system failure is unlikely: <ul style="list-style-type: none"> - conventional nav aids may be used for gross error checks and monitoring of GPS guidance - ATC may require a non-GPS procedure to be flown for operational reasons - IFR workload, particularly in demanding weather and traffic conditions, may not allow much time for a pilot to troubleshoot or reprogram a GPS; eg. after holds and vectors have disrupted guidance sequencing for an active procedure. <i>In such circumstances, it may be safer and easier to revert to and request a conventional procedure from ATC</i>
Weather forecasts for destination and alternate. GPS NPA and alternate minima	<ul style="list-style-type: none"> The normal IFR planning requirements apply to GPS NPAs Note that the appropriate minima for GPS NPAs are “LNAV” ones; RNAV approach charts may also include minima for “LNAV/VNAV” or other procedures If the destination weather is such that an alternate airport is required, the alternate <i>must have a non-GPS instrument approach procedure</i> which is anticipated to be operational and available at the estimated time of arrival, and which the aircraft is equipped to fly
RAIM prediction	<ul style="list-style-type: none"> GPS NPAs require RAIM prediction to be performed and to indicate that RAIM will be available at the destination ETA. The UK CAA recommend that RAIM should be available for a 15 minutes either side of ETA. In Europe, http://augur.ecacnav.com/ may be used for RAIM prediction, and is preferable to using the GPS Receiver’s built-in prediction software
NOTAM check	<ul style="list-style-type: none"> The pilot’s review of applicable pre-flight NOTAMs should include a check of the availability of GPS, conventional and missed approach procedures and of radio aids Note that, whilst GPS NPAs are relatively immature in Europe, published GPS procedures may <u>not</u> be available for prolonged periods, or at short notice; for example, due to ATC staff training requirements

GPS NPA operations (2) Pre-Flight Checks

Operating Procedure	Notes and comments
GPS database currency and coverage	<ul style="list-style-type: none"> The GPS receiver must use a current database, supplied from a source approved by the manufacturer As well as checking the overall geographic coverage, the pilot must ensure the database includes the specific airports and the individual procedures that may be required <i>example: extract from Garmin 530 database validity page on start-up</i> <div data-bbox="1671 336 2063 507" style="background-color: #0000FF; color: #00FFFF; padding: 5px;"> <p style="text-align: center;">Cycle 0711</p> <p>Effective 25-OCT-07</p> <p>Expires 22-NOV-07</p> </div>
Check coding of expected GPS NPA procedures against paper charts	<ul style="list-style-type: none"> Prior to using a procedure from the database, the pilot must check that it matches the published procedure chart. A review of waypoint sequence, tracks and distances is adequate; Lat/Long coordinates must only be checked if there is a potential discrepancy This review may be done pre-flight, and it is useful to check all of the potential GPS NPAs and transition identifier selections at this point, in order to minimise in-flight workload Whilst coding errors are rare, it is common for GPS databases to include some waypoints which do not appear on paper charts, or to use different identifiers (see Sections 2b and 2c of this manual)
GPS receiver self-test, user selectable settings, LOI monitoring	<ul style="list-style-type: none"> When the GPS unit is powered-up, the pilot should verify that the self-test procedure is successful After a position fix has been acquired, the pilot should monitor the GPS for Loss of Integrity alerts at all times UK CAA CAP773 (see Part 2 and Appendix 2) recommends that the status of all the user-definable GPS settings should also be checked, in particular where an aircraft is flown by a more than one pilot. Such checks may include: Set CDI scaling to 'automatic'; Check setting of alarms, airspace and altitude buffers; Check Map display settings, de-clutter and map orientation; Check heading and track display (magnetic, true etc...); Check map datum to WGS 84; Check the units of measure of distance, speed, altitude, barometric pressure and position format; Select display to show at least: Desired Track (DTK) / Groundspeed (GS) / Distance to next waypoint (DIS); Check date and time format; Check setting of other units of measure such as fuel quantity
Flight plan entry and RAIM prediction	<ul style="list-style-type: none"> The enroute flight plan may be entered at this point and a GPS RAIM prediction performed, either in lieu of or to update a prediction from an internet site such as AUGUR The RAIM prediction should be repeated whenever the destination ETA changes by more than ~15 minutes
Requirement to use a database coded procedure for GPS NPAs	<ul style="list-style-type: none"> All the regulatory sources emphasise that an RNAV terminal or approach procedure must only be flown using guidance based on a procedure record loaded from the GPS database <i>This procedure record must not be amended by any user entries, and, in particular, a procedure created from user-entered waypoints may never be used</i>

GPS NPA operations (3) Pre-Arrival

Operating Procedure	Notes and comments
<p>Selecting and checking the Approach procedure</p> <p>Determining the appropriate IAF</p>	<ul style="list-style-type: none"> When cleared by ATC for a GPS NPA (ideally, >30nm from the destination), the procedure should be selected from the database but not (subject to the GPS unit logic) 'activated', 'loaded' into the active flight plan, or 'armed' If ATC do not provide a clearance to a specific IAF, the correct IAF should be determined based on the aircraft's bearing to the IF and the arrival quadrant information in the approach chart (see section 4a). This IAF should be selected from the transition identifier list in the procedure record ATC clearances should be read back carefully; some TMAs have a large number of similar sounding RNAV waypoints At this point, a final cross-check of the selected procedure should be performed <ul style="list-style-type: none"> firstly, checking that the correct Airport, Procedure, Transition and Runway identifiers have been selected secondly, checking that the database waypoints correspond to the published chart
<p>Activation of the procedure and CDI scaling</p>	<ul style="list-style-type: none"> If the GPS procedure is satisfactory, it may be activated in the active flight plan "GPS" (rather than "VLOC") mode should be selected for the receiver CDI output, and the correct annunciator display should be verified Within 30nm of the destination, the CDI should scale to 1nm (max deflection) and "TERM" mode (or equivalent) should be displayed <p>Example: Garmin 530 mode annunciation CDI sensitivity 1nm in Terminal mode CDI output toggled from VLOC to GPS</p> 

- When database terminal and approach procedures are active, IFR GPS units automatically adjust the CDI full-scale deflection and the RAIM position integrity alarm to the limit appropriate for each phase of flight
- Garmin example:

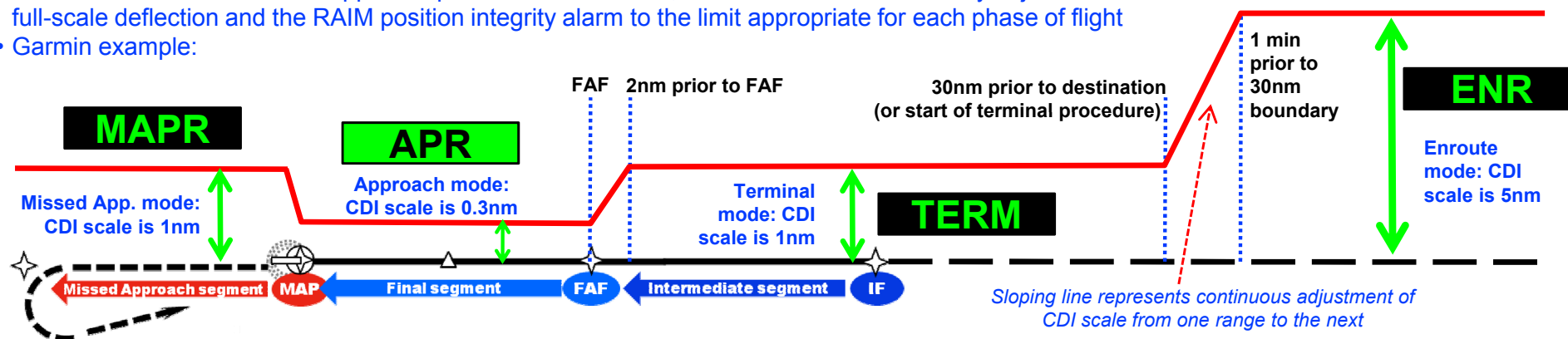

GPS NPA operations (4) Flying the GPS NPA

Operating Procedure	Notes and comments
Checks approaching the IAF	<ul style="list-style-type: none"> • Prior to the IAF the pilot should perform a gross error check of the aircraft position (using non-GPS navigation if possible) • Recheck that the procedure is active and the GPS is in TERM mode with CDI scaling of 1.0nm • <i>The GPS will provide excellent “micro” situational awareness in tracking from one waypoint to the next. The pilot must also maintain “macro” situational awareness with respect to the destination airport, radio aids, airspace boundaries, traffic, weather and terrain</i> • Set up any conventional radio aids required for the missed approach, or which may provide supplementary guidance (eg. DME). If the missed approach is an RNAV procedure, also brief a non-RNAV missed approach in case of GPS failure (or determine a safe course of action if a non-RNAV MAP is not available)
GPS and Navigation instrument mode selection and flight guidance	<ul style="list-style-type: none"> • Prior to the first waypoint, the pilot should reconfirm the CDI output to the HSI is toggled to “GPS” mode, and that the GPS Map or Nav page settings are suitable for guidance during the procedure • The pilot should establish a “mini checklist” for each procedure segment, for example: <ul style="list-style-type: none"> - <i>approaching a waypoint, self-brief on the next track, distance and level</i> - <i>when the GPS announces 10s to next waypoint, set the HSI to the next track</i> - <i>monitor the GPS receiver (not the HSI) during the 10s countdown, and be prepared to promptly establish a Rate 1 turn as soon as the GPS display says “Turn now to XXX°”</i> • In particular, note that most GPS receivers display only <u>distance to the next waypoint</u> during a procedure, not DME-style distance to the runway threshold
Use of the GPS receiver if a hold or vectors to an intermediate waypoint on the NPA are required	<ul style="list-style-type: none"> • <i>The operating logic of most GPS receivers makes it relatively easy to learn how to load and activate a procedure and follow the guidance from waypoint to waypoint</i> • <i>Conversely, the same operating logic can be quite difficult and confusing when inevitable ‘real world’ disruptions occur (ATC vectors and holds; changes of IAF, procedure or runway; direct clearances to intermediate waypoints)</i> • <i>A pilot must be trained in managing such tactical changes to the GPS flight plan (see sections 5 and 6 of this manual)</i>
Check activation of APP mode prior to the FAF	<ul style="list-style-type: none"> • Within 2nm of the FAF, the pilot <u>must check that the GPS APR (Approach) mode is active</u> – this is a critical check which also ensures that the CDI scaling is adjusting correctly and that RAIM is predicted to be available for the approach. Descent on the final approach must not commence unless “APR” mode is active • After the FAF, if RAIM or position integrity is lost, the GPS will continue to provide track guidance for 5 minutes, but, despite this, the pilot must initiate the Missed Approach immediately



• In addition to this brief summary, any private pilot intending to fly GPS NPAs should study the appropriate official guidance material: FAA AIM Section 1-1-19-n and/or CAP773 Part 2 & Appendix 2

GPS NPA operations (5) Flying the Missed Approach

Procedure	Notes and comments
<p>Activation of the Missed Approach procedure and the need to manually re-initiate waypoint sequencing</p>	<ul style="list-style-type: none"> • GPS database procedures are coded such that the Runway Threshold waypoint is <u>always</u> the Missed Approach Point. This also applies to “database overlays” of conventional procedures, where the published MAP is often a beacon beyond the runway threshold (in this case, the charted MAP will be the next waypoint <u>after</u> a CNF at the runway threshold. This CNF is encoded as the missed approach procedure transition point in the database; see section 2c of this manual) • A strict logic applies in all IFR-certified GPS receivers. Up to the <u>coded</u> MAP, waypoint sequencing is automatic. At the coded MAP, automatic sequencing is suspended and the pilot must manually re-initiate guidance for the missed approach. In the Garmin 430/530 series, a “SUSP” annunciation indicates that sequencing is suspended, and the “OBS” key must be pressed to recommence sequencing • Until sequencing is re-initiated, the GPS receiver will continue providing guidance along the final approach track • Even if the Missed Approach procedure mode is initiated before the MAP (eg. with a direct-to the MAP), waypoint sequencing will be suspended at the MAP • This logic may appear somewhat strange, but it is essential– it means that there is no risk of automatic waypoint sequencing unexpectedly changing the GPS LNAV guidance at a critical point late in the final approach or early in the go-around when the aircraft may be too low or slow to change track safely • Therefore, a pilot flying the Missed Approach procedure must always manually re-initiate waypoint sequencing after the MAP is reached and the “SUSP” annunciator is displayed
<p>Mode selection and pilot actions in non-RNAV missed approach segments</p>	<ul style="list-style-type: none"> • During the missed approach, the GPS will always provide track guidance and waypoint sequencing for “RNAV friendly” path-terminators such as a TF (Track to Fix) segments • However, even standalone RNAV Approaches often need to use path-terminators that are not fully supported by GPS receivers. Such procedure segments will be listed in the flight plan, but some combination of the following is possible <ul style="list-style-type: none"> – automatic waypoint sequencing is suspended (for example, the GPS may not “know” when a conditional terminator, such as “2000’ or 4DME - whichever is earlier”, is reached) – track guidance through the CDI is not provided, neither is autopilot LNAV guidance available – the GPS Map may not display a ‘magenta line’ for the segment • Path-terminator support is specific to individual GPS models (and sometimes different software versions for the same receiver). A pilot must be familiar with the GPS user manual instructions on waypoint sequencing and path-terminator support, and prepared to fly the missed approach procedure using conventional navigation techniques (except for the “pure” RNAV legs where this is not possible, and full GPS guidance will be provided by any IFR-approved receiver)

Operating Procedure	Transcripts from UK CAA CAP773 Appendix 3
<p>Communications during normal procedures</p>	<p>Pilots should request clearance to fly the procedure using the phraseology: <i>'(Aircraft c/s), request RNAV approach, via (Initial Approach Fix Designator), runway xx'</i></p> <p>Where traffic conditions permit, air traffic controllers shall clear the pilot to follow the procedure using the following phraseology: <i>'(Aircraft c/s), cleared RNAV approach, runway xx, (report at [Initial Approach Fix designator])'</i></p> <p>For traffic sequencing and to aid situational awareness, air traffic controllers may request the pilot to report when established on final approach track or to report at any other relevant point in the procedure. For example: <i>'(Aircraft c/s), report established on final approach track'</i> <i>'(Aircraft c/s), report 2 miles from final approach fix'</i></p> <p>Air Traffic Controllers shall instruct the pilot to report at the final approach fix, using the phraseology: <i>'(Aircraft c/s), report final approach fix'</i></p> <p>After reaching the final approach fix, the pilot will continue to fly the procedure towards the next waypoint (normally the runway threshold). At the appropriate time, the pilot will either continue with the air traffic clearance received or will execute the Missed Approach Procedure (MAP).</p>
<p>Communications in the event of a GPS navigation failure</p>	<p>When Air Traffic Control is aware of problems with the GNSS system, the following phraseology shall be used: <i>'(Aircraft c/s), GNSS reported unreliable (or GNSS may not be available [due to interference]): In the vicinity of (location) (radius) [between (levels)] OR In the area of (description) [between (levels)]'</i> <i>'(Aircraft c/s), GNSS unavailable for (specify operation) [from (time) to(time) (or until further notice)]'</i></p> <p>Following a RAIM indication, pilots shall inform the controller of the event and subsequent intentions. <i>'(Aircraft c/s) GNSS unavailable (due to [reason eg Loss of RAIM OR RAIM alert]) (intentions)'</i> <i>'(Aircraft c/s) Loss of RAIM or RAIM alert (intentions)'</i></p>

- 

In general, the ICAO standard is that if a pilot can not comply with RNAV requirements or experiences an RNAV failure, the radio call to ATC should be *"(Aircraft c/s), Unable RNAV due equipment"* followed by a request for an alternative course of action as appropriate

GPS NPA operations (7) Contingencies in the event of a GPS navigation failure

- Before a GPS NPA has commenced, there are three additional contingencies a pilot should plan for in addition to the conventional IFR approach contingencies
 - a GPS Loss of Integrity alert or a GPS position alarm, warning that the aircraft has deviated beyond the required lateral protection limit
 - A failure of the GPS to automatically sequence to Approach mode at the FAF
 - any uncertainty about whether the procedure may be continued safely; for example: a navigation cross-check discrepancy, a pilot’s confusion about the GPS guidance or mode status, excessive deviation from the vertical profile

Illustration of contingency procedures	
Immediate actions	<p><u>Aviate</u>: stop any descent and configure the aircraft appropriately</p> <p><u>Navigate (if prior to the Intermediate fix)</u> continue on current heading if able to immediately contact ATC and request vectors to an alternative procedure, otherwise turn to the MAP</p> <p><u>Navigate (if after the Intermediate fix)</u> continue on final approach track, check the missed approach procedure, select non-GPS aids as required and continue (or turn to) to the MAP. If a non-RNAV missed approach is not available, the pilot should have determined an appropriate course of action prior to the approach</p> <p><u>Communicate</u>: advise ATC “(Aircraft c/s), Unable RNAV due equipment” and/or as appropriate</p>
Reverting to alternative procedures	<p>The “default” contingency in the event of an RNAV failure is to fly the missed approach and request ATC clearance for a conventional procedure at the destination airfield. If no conventional procedure is available, the flight will have been planned with an alternate airport that does have a conventional procedure or where VFR conditions are forecast</p> <p>In practice, ATC may be able to provide vectors directly to a conventional approach if the failure is early in the procedure. If a conventional procedure is not available, and fuel reserves permit, the pilot may request a hold to allow the GPS to be reprogrammed or to wait for RAIM availability to be restored</p>

 • The GPS User Manual forms part of the aircraft Flight Manual in an IFR approved installation, and the pilot must follow any limitations or contingency procedures it specifies

1. RNAV and RNP theory
 - a. Introduction
 - b. The Path-Terminator
 - c. RNAV procedure design
 - d. RNP principles
 - e. RNAV and RNP applications
 2. GPS Navigators and their application to RNAV
 - a. The GPS system
 - b. Databases and Coding
 - c. Procedures
 - d. Error detection and warnings
 3. P-RNAV Terminal Procedures
 - a. P-RNAV requirements and approvals
 - b. P-RNAV training topics
 - c. P-RNAV operations
 4. RNAV(GPS) Approach Procedures
 - a. GPS procedure types
 - b. GPS approach requirements and approvals
 - c. GPS approach operations
- 5. Avionics training**
6. Simulator and/or Flight training

GPS training for P-RNAV and/or NPA operations

1. Introductory comments

- When private pilots use GPS as a supplementary navigation aid, or as a primary aid in less-demanding enroute applications, they generally do not have to complete any formal training. Such GPS skills can often be achieved by studying a user manual and practising in good VFR conditions
 - Formal GPS training is always required for P-RNAV (see section 3) and always recommended, sometimes required, for GPS NPAs (see section 4)
 - The particular challenge for Terminal and Approach RNAV operations is to be
 - proficient in all the “combinations” of operating modes and selection changes that may be required (eg. loading a procedure, being vectored then asked to hold, having the landing runway change and needing to activate another procedure)
 - familiar with the details of GPS guidance in each of the operating modes and procedure variants (eg. does the CDI indicate deviation through the curved track of a fly-by turn, or flip from one track to the next halfway through?)
 - Much of this proficiency is specific to individual models of GPS. The operating logic of receiver models is sufficiently varied that an expert user may struggle with the specialised IFR features in an unfamiliar model of GPS, even if they are able to use the basic navigation functions quite easily
-  • **Assuming basic “enroute” IFR GPS skills as starting point, we recommend that pilots and instructors should focus RNAV training on 4 specific topics detailed on the next page**
- The reference pages later in this section have an example of an approved ‘basic’ training syllabus for the Garmin 430/530 series

GPS training for P-RNAV and/or NPA operations

2. RNAV training topics (specific to individual models of GPS receiver)

Topic	Training objectives
1. Loading, briefing and activating procedures	<ul style="list-style-type: none"> • Familiarity with terminal and approach procedure selection and briefing <ul style="list-style-type: none"> – selecting and verifying Transition, Procedure, Runway and Airport identifiers – displaying waypoints prior to activating the procedure, in order to cross-check against paper charts – loading, activating or arming the procedure (terminology and logic varies by GPS model) – changing or deleting the selected procedure before and after activation/arming – modifying the enroute flight plan so any 'overlap' with a procedure is removed (eg. if the enroute plan ends at a waypoint <i>after</i> the first waypoint of an arrival)
2. Fly-By waypoint guidance	<ul style="list-style-type: none"> • Understanding turn anticipation in the case of Fly-By waypoints <ul style="list-style-type: none"> – is the waypoint ETE the time to the start of the turn, or the time to notionally cross the waypoint? – roughly how many seconds prior to a waypoint do turns begin, based on track change and ground speed? – when is the next track after a waypoint annunciated? – when is the turn countdown annunciated? Is the countdown displayed continuously? – when and how is the turn command annunciated? • Understanding turn guidance through Fly-By waypoints <ul style="list-style-type: none"> – does the GPS map provide any curved track guidance through the turn? – does the GPS CDI 'flip' from one track to the next in mid-turn, or does it provide deviation information relative to the calculated turn path? – does the coupled HSI CDI provide the same information? – does the GPS provide the correct turn guidance to a Flight Director and/or Autopilot in NAV mode, and in GPSS mode if available? – how does a Position Alarm alert you to a breach of the RNP protection limit (eg. if you miss a turn)
3. Tactically modifying a flight plan	<ul style="list-style-type: none"> • Changing the procedure selection after it has become active <ul style="list-style-type: none"> – how is the new procedure activated? What if the aircraft has passed some of the initial waypoints? • Selecting "Vectors-to-final" at the start of or during a procedure <ul style="list-style-type: none"> – how do you restore procedure guidance if ATC cancel vectoring and direct you to rejoin the procedure? • Following ATC instructions <ul style="list-style-type: none"> – does the Direct-to button provide straight-line guidance to a waypoint (the leg terminator), or an intercept to the leg path prior to the terminator? Is there a choice of Direct-to or Fly-Leg guidance? – if instructed to hold at a waypoint, what GPS guidance is available? How is the procedure re-engaged at the end of a hold? • Using the Missed Approach procedure <ul style="list-style-type: none"> – proficiency in re-initiating waypoint sequencing after the MAP, and in the guidance available for non-TF path terminators found in Missed Approach procedures – activating the Missed Approach procedure before the MAP. Does the GPS mode change from "APP" to "MAPR" immediately? What guidance is provided to the MAP from a waypoint before the FAF?
4. Refresher of GPS basics	<ul style="list-style-type: none"> • GPS validation on start-up: Database currency and coverage. Self-test. Settings. RAIM prediction • GPS essentials during RNAV operation: forms of LOI alert and other position and integrity messages. CDI scaling and mode annunciation. Recovering the flight plan if the GPS is powered down and restarted.

3. Training methods

- GPS user manuals and other training products for private pilots tend to describe only the basics of how to load and fly a database procedure and the key RNAV operating functions (eg. RAIM prediction, LOI alerts, CDI and mode activation)
- Proficiency to the level of depth described on the previous page is probably best acquired, initially, by using the manufacturer's GPS simulator software, or the actual GPS unit in Simulator mode if the software is not available (see reference page that follows for Garmin software downloads)
- Because actual procedures and airspace may not be easily available for the flight training required, RNAV training will often be conducted in a synthetic training device with a suitable panel-mount GPS (eg. a JAA FNPT2 or an FAA approved FTD, these are not, strictly speaking, "simulators" but will be referred to as such)
- However, this training will be more efficient and cost-effective if the pilot is already proficient in the GPS topics described on the previous page
- Our recommendation is that, prior to formal simulator or flight training, a pilot should
 - re-read the GPS user manual with particular emphasis on the RNAV operating features and functions highlighted in this manual (see example at the end of this section)
 - spend at least 2-3 hours practising with the GPS simulator software: firstly creating scenarios with suitable RNAV procedures (and with the paper charts to hand) and then 'flying' those scenarios on the software simulator, becoming proficient in the training objectives described on the prior page
- The training objectives in the prior page are also ones we recommend instructors and flight schools include in GPS RNAV ground, simulator and flight training

Introductory/Basic GPS training syllabus example

http://www8.garmin.com/manuals/288_SampleTrainingSyllabus.pdf



GARMIN.

Garmin GNS 530/430

**Sample Training Syllabus
and Flight Lessons
for Use by
Flight Schools & Flying Clubs**





TABLE OF CONTENTS

Copyright	i
Table of Contents	ii
Introduction	1
Overview	
Home Study Worksheets	2
GNS 530/430 Home Study 1.....	3
Worksheet – Use of GPS in lieu of other avionics, regulations	
GNS 530/430 Home Study 2.....	4
Worksheet – Terminology Review	
GNS 530/430 Home Study 3.....	5
Worksheet – COM and VLOC Operation	
GNS 530/430 Home Study 4.....	6
Worksheet – Direct-to and Flight Plan Navigation	
GNS 530/430 Home Study 5.....	7
Worksheet – Arrival, Departure and Approach Procedure Operation	
GNS 530/430 Home Study 6.....	8
Worksheet – GNS 530/430 Series Display Interfaces; TIS	
GNS 530/430 Home Study 7.....	9
Worksheet – GNS 530/430 Series Display Interfaces; GDL 49 Weather	
GNS 530/430 Home Study 8.....	10
The Role of Avionics in Aeronautical Decision Making and Single-Pilot Resource Management	
GNS 530/430 Flight Orientation	12
Lesson 1: GNS 530/430 Introduction - Cross-Country Flight	13
Lesson 2: Local Operational Flight Review.....	14
Lesson 3: GNS 530/430 Dual Installation Introduction	15
Lesson 4: Dual Installation MFD Operations	16

ii

Garmin GNS 530/430 Sample Training Syllabus and Flight Lessons

190-00334-00 Rev. A

Garmin 430/530 free Simulator software download

<http://www8.garmin.com/include/SimulatorPopup.html>

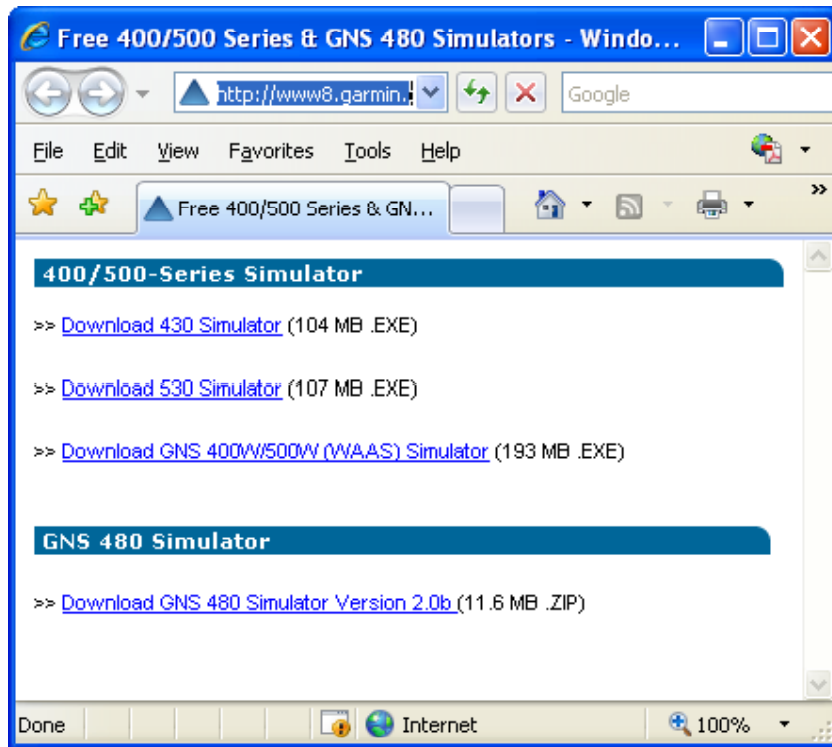

Example: studying Fly-By turns for the Garmin 430/530

Garmin manual extract and illustrative simulator software screenshots

APPENDIX C MAP DATUMS

When does turn anticipation begin, and what bank angle is expected?

The GNS 530 smooths adjacent leg transitions based upon a nominal 15° bank angle (with the ability to roll up to 25°) and provide three pilot cues for turn anticipation:

- 1) A waypoint alert ('NEXT DTK ###°') flashes in the lower right corner of the screen 10 seconds before the turn point (Figure C-6).
- 2) A flashing turn advisory ('TURN TO ###°') appears along the bottom of the screen when the aircraft is to begin the turn. Set the HSI to the next DTK value and begin the turn.
- 3) The To/From indicator on the HSI (or CDI) flips momentarily to indicate that the aircraft has crossed the midpoint of the turn. For more information on waypoint alerts and turn advisories, see Sections 6.2 and 6.3.



Example: GNS530 simulator screenshots during a Fly-By turn



SECTION 16 – MESSAGES, ABBREVIATIONS, & NAV TERMS

Steep turn ahead - This message appears approximately one minute prior to a turn in one of the following three conditions: 1) the turn requires a bank angle in excess of 25° in order to stay on course, 2) the turn requires a course change greater than 175°, or 3) during a DME arc approach the turn anticipation distance exceeds 90 seconds.

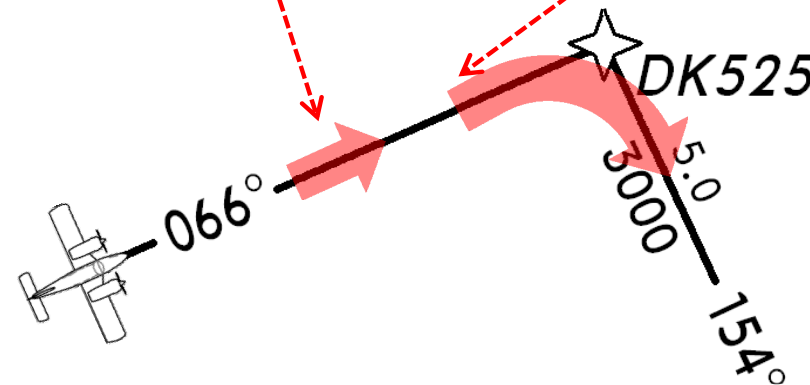

1. RNAV and RNP theory
 - a. Introduction
 - b. The Path-Terminator
 - c. RNAV procedure design
 - d. RNP principles
 - e. RNAV and RNP applications
2. GPS Navigators and their application to RNAV
 - a. The GPS system
 - b. Databases and Coding
 - c. Procedures
 - d. Error detection and warnings
3. P-RNAV Terminal Procedures
 - a. P-RNAV requirements and approvals
 - b. P-RNAV training topics
 - c. P-RNAV operations
4. RNAV(GPS) Approach Procedures
 - a. GPS procedure types
 - b. GPS approach requirements and approvals
 - c. GPS approach operations
5. Avionics training
- 6. Simulator and/or Flight training**

P-RNAV simulator and/or flight training

Training course objectives and structure

- The training and operating requirements for P-RNAV are detailed in Section 3 of this manual and summarised in the table below. Our recommendation is that a P-RNAV training course should have the following three parts:

Theory Training objectives (key points)
General RNAV theory <ul style="list-style-type: none">- differences between B-RNAV, P-RNAV and RNP-RNAV- meaning of RNP/ANP, limitations of RNAV, GPS concepts
P-RNAV theory <ul style="list-style-type: none">- RNP-1 definition as it relates to P-RNAV requirements- airspace where P-RNAV is required- changes to charting and documents to reflect P-RNAV- required navigation equipment for flight in P-RNAV airspace
Charting, database and avionics topics <ul style="list-style-type: none">- Waypoint naming concepts- the 'TF' and 'CF' path terminators- fly-by and fly-over waypoints
Simulator and/or Flight Training objectives
Operational procedures and practices <ul style="list-style-type: none">- Normal procedures (TGL10.2)- Contingency procedures (TGL10.3)
Use of RNAV Equipment <ul style="list-style-type: none">- retrieving a procedure from the database- briefing the procedure, comparing it with the charted procedure- action to be taken if discrepancies are noted- sensor management- tactically modifying the flight plan
Flying P-RNAV procedures <ul style="list-style-type: none">- LNAV and associated lateral control techniques,- VNAV and vertical control techniques,- use of automatic pilot and flight director- implications of system malfunctions not RNAV related

PART 1: GROUND THEORY

Self-study method:

A pilot may use this manual to self-study P-RNAV theory; the required pages are marked with a **P** in the top right corner. The Instructor should, as a minimum, conduct an oral exam to ensure the pilot is fully proficient in the key knowledge items listed in the table on the left

or, Classroom training method:

The instructor may conduct classroom training to cover the required P-RNAV material in this manual. This may involve several 2-3hr classroom sessions, depending on how much preparation and reading the student has done

PART 2: PRE-FLIGHT BRIEFING

The pre-flight briefing sessions may require 1-2hrs, and should include:

Use of RNAV Equipment

Covering the four avionics topics detailed in Section 5 of this manual

RNAV Operational procedures

Covering section 3c of this manual, and using the actual aircraft or training device checklist/ops manual

PART 3: SIMULATOR OR FLIGHT TRAINING

The training syllabus we recommend is based on 2 "notional" lessons

1. Normal P-RNAV operations

2. P-RNAV contingencies

The objective is for the pilot to demonstrate proficiency to the standards required of Instrument Rating holders and the specific requirements of P-RNAV. The minimum time this will require is probably 2-3hrs for a candidate who is current in IFR and GPS operations.

 • Our recommend content for these flight lessons is detailed in the next two pages

P-RNAV Lesson 1: Normal Operations

Element of Lesson	Content recommendations
1. Pre-flight preparation	<ul style="list-style-type: none"> • Briefing of route and procedure charts. Availability of non-PRNAV procedures • RAIM check using AUGUR (requires internet access) and the GPS unit's built-in prediction tool • Briefing on power, pitch and configuration for a high speed arrival • Other items in accordance with the P-RNAV checklist or ops manual
2. P-RNAV SID #1 (manually flown)	<ul style="list-style-type: none"> • A normal IFR departure, flying the P-RNAV SID to its terminating point <i>note the path-terminators at the start of the procedure which may not be supported by the GPS, and the transition to GPS LNAV guidance</i>
3. Short cruise segment	<ul style="list-style-type: none"> • A cruise segment to the start of the arrival procedure, using an enroute GPS flight plan <i>a simulator should be slewed as required to reposition the aircraft, only 10mins in the cruise are needed to complete the pre-arrival checks</i>
4. P-RNAV STAR#1 (manually flown)	<ul style="list-style-type: none"> • A normal P-RNAV STAR, transitioning to an ILS low approach and go-around <i>although the approach is not required as part of P-RNAV training, practising the transition from GPS guidance to the ILS or other radio approach aids should be included where practical</i>
<i>Repositioning as required</i>	
5. P-RNAV SID #2 (autopilot)	<ul style="list-style-type: none"> • A normal IFR departure, flown using the autopilot, to the SID airways terminating point <i>note the point on the procedure at which autopilot LNAV may be engaged, and the use of available VNAV features</i>
6. Short cruise segment	
7. P-RNAV STAR#2 (autopilot) with continuous descent at required or maximum performance	<ul style="list-style-type: none"> • A P-RNAV STAR, transitioning to an ILS low approach and go-around, flown using the autopilot in LNAV and coupled ILS modes • Subject to the type of aircraft flown/simulated, this procedure should be flown at highest arrival speed attainable up to the published chart maximum, and, if possible, at 160KIAS to 4 DME on the ILS • The P-RNAV star should offer a continuous descent profile (most do, but some older procedures have a stepped arrival) <i>A pilot's instrument training will have been conducted at the aircraft's normal arrival/approach speeds, and it useful for the P-RNAV training to include faster arrivals that may be requested by ATC. The limiting speeds for gear and flap, good engine management and speed control in the transition to the ILS glideslope should be briefed pre-flight.</i>
Tactical changes	<ul style="list-style-type: none"> • The procedure training above should ideally include at least one each of an unplanned hold, a change of RNAV procedure, and a direct-to clearance to an intermediate waypoint

Element of Lesson	Content recommendations
1. Pre-flight preparation	<ul style="list-style-type: none"> Briefing of route and procedure charts. Availability of non-PRNAV procedures Review of RNAV and other contingency procedures in the check list or ops manual
2. Non-RNAV contingencies: P-RNAV SID (optional) Short cruise (optional) P-RNAV STAR#3	<ul style="list-style-type: none"> To include at least one P-RNAV STAR (flown manually or using the autopilot) in which RNAV performance is normal, but other simulated failures or contingencies are introduced which the pilot must manage whilst flying the full procedure <i>The failures may be specific to the aircraft type, but may include instrument, electrical, engine and fuel system problems; icing or storm avoidance; and, in a multiengine trainer or aircraft, an engine failure may be simulated during the arrival</i> <i>The failures should permit the procedure to be flown in full, but the debriefing should emphasise circumstances in which an alternative course of action or declaring an emergency would be needed</i> This element of Lesson 2 should include at least one tactical change (unplanned hold, change of RNAV procedure, vectors)
<i>Repositioning as required</i>	
3. RNAV contingencies: P-RNAV SID (optional) Short cruise (optional) P-RNAV STAR#4	<ul style="list-style-type: none"> As a minimum, this should include one P-RNAV procedure in which a simulated loss of RNAV capability takes place (eg. a failure of the GPS or a RAIM Loss of Integrity) in which the pilot must follow the checklist contingency procedures and then fly a conventional or radar-vector arrival If a simulator is used which permits other RNAV failures, these may be included (eg. a discrepancy in a cross-check between GPS position and radio aids)

P-RNAV differences training or completion of training

If the aircraft or simulator used for Lessons 1 and 2 is not representative of the actual aircraft or specific model of GPS to be used for P-RNAV operations, the course should be completed using an appropriate combination of representative PC GPS simulator software, flight training device or aircraft

Element of Lesson	Content recommendations
1. Pre-flight preparation	<ul style="list-style-type: none"> Briefing of route and procedure charts. Availability of non-PRNAV procedures RAIM check using the GPS unit's built-in prediction tool Briefing on power, pitch and configuration for a high speed arrival Review of P-RNAV normal and contingency procedures in the check list or ops manual
2. Normal RNAV procedure	<ul style="list-style-type: none"> To include at least one RNAV procedure (SID, STAR or Approach) and at least one tactical change (unplanned hold, change of RNAV procedure, vectors)

GPS NPA simulator and/or flight training

Training course objectives and structure

- The training and operating requirements for GPS NPAs are detailed in Section 4 of this manual and summarised in the table below. Our recommendation is that a training course should have the following three parts:

Theory Training objectives (key points)
General RNAV theory - meaning of RNP/ANP, limitations of RNAV, GPS concepts
GPS NPA theory - GPS procedure designs and coding - GPS NPA procedure charts, limitations and minima - requirement for current database and database procedures only - required navigation equipment for GPS NPAs
Charting, database and avionics topics - Waypoint naming concepts - the 'TF' and 'CF' path terminators - fly-by and fly-over waypoints
Simulator and/or Flight Training objectives
Operational procedures and practices - Normal procedures - Contingency procedures
Use of RNAV Equipment - retrieving a procedure from the database - briefing the procedure, comparing it with the charted procedure - action to be taken if discrepancies are noted - sensor management - tactically modifying the flight plan
Flying GPS NPA procedures - LNAV, VNAV and associated control techniques, - use of automatic pilot and flight director - missed approach and contingency procedures (eg. loss of RAIM) - ATC procedures

PART 1: GROUND THEORY

Self-study method:

A pilot may use this manual to self-study GPS NPA theory; the required pages are marked with a **A** in the top right corner. The Instructor should, as a minimum, conduct an oral exam to ensure the pilot is fully proficient in the key knowledge items listed in the table on the left

or, Classroom training method:

The instructor may conduct classroom training to cover the key GPS NPA material in this manual. This may require one or two 2-3hr classroom sessions, depending on how much preparation and reading the student has done

PART 2: PRE-FLIGHT BRIEFING

The pre-flight briefing sessions may require 1-2hrs, to include:

Use of RNAV Equipment

Covering the four avionics topics detailed in Section 5 of this manual

RNAV Operational procedures

Covering section 4c of this manual, and using the actual aircraft or training device checklist/ops manual

PART 3: SIMULATOR OR FLIGHT TRAINING

The training syllabus we recommend is based on 2 "notional" lessons

1. Normal GPS NPA operations
2. GPS NPA contingencies

The objective is for the pilot under training to demonstrate proficiency to the standards required of Instrument Rating holders and the specific requirements of GPS NPAs. The minimum time this will require is probably 2hrs for a candidate who is current in IFR and GPS operations.

- ➔ • Our recommend content for these flight lessons is detailed in the next two pages
- See also the syllabus in UK CAA CAP773 Appendix 1

GPS NPA Lesson 1: Normal Operations

Element of Lesson	Content recommendations
1. Pre-flight preparation	<ul style="list-style-type: none"> • Briefing of route and procedure charts. Availability of conventional approaches and alternates • RAIM check using AUGUR (requires internet access) and the GPS unit's built-in prediction tool • Briefing of GPS and 'normal' IFR checklist items • Entering a GPS flight plan from departure to destination
2. IFR departure and short cruise segment (manually flown)	<ul style="list-style-type: none"> • A normal IFR departure and short cruise segment, using the GPS, as appropriate, for supplementary or primary guidance
3. GPS Non-Precision Approach #1 (manually flown)	<p>Pre-Arrival</p> <ul style="list-style-type: none"> • Selecting and checking the Approach procedure • Determining the appropriate IAF • Activation of the procedure and CDI scaling <p>Flying the GPS NPA procedure</p> <ul style="list-style-type: none"> • Gross error check approaching the IAF, and check that the GPS is in TERM mode with CDI scaling at 1nm • GPS and Navigation instrument mode selection • Check activation of APP mode and CDI scaling to 0.3nm prior to the FAF <p>Flying the Missed Approach</p> <ul style="list-style-type: none"> • Activation of the Missed Approach procedure and the need to manually re-initiate waypoint sequencing • Mode selection and pilot actions in non-RNAV missed approach segments
<i>Repositioning as required</i>	
4. GPS Non-Precision Approach #2 and #3 with tactical changes (manually flown or using autopilot)	<p>This procedure should include all of the "normal" items in Element 3 above, but it should be a scenario in which the instructor simulates a series of ATC tactical changes; for example:</p> <ul style="list-style-type: none"> • An unplanned hold at the IAF • During the hold, a change of runway requiring a new procedure to be loaded • A direct-to clearance to the IAF • A missed approach, followed by Vectors to the FAF of the same procedure
SIDs and STARs	<ul style="list-style-type: none"> • <i>Although not essential, the lesson may include, if possible, use of the GPS with SID and STAR procedures prior to the NPA, emphasising that radio aids must be used as primary guidance for non-RNAV procedures</i>

GPS NPA Lesson 2: Contingencies

Element of Lesson	Content recommendations
1. Pre-flight preparation	<ul style="list-style-type: none"> Briefing of route and procedure charts. Review of RNAV and other contingency procedures in the checklist
2. Non-RNAV contingencies: GPS Non-Precision Approach #4	<ul style="list-style-type: none"> To include at least one GPS NPA (flown manually or using the autopilot) in which RNAV performance is normal, but other simulated failures or contingencies are introduced which the pilot must manage whilst flying the approach <i>The failures may be specific to the aircraft type, but may include instrument, electrical, engine and fuel system problems</i> <i>In a multiengine trainer or aircraft, an engine failure should be simulated during the arrival</i> <i>The failures should permit the approach to be flown in full, but the debriefing should emphasise circumstances in which an alternative course of action is preferable</i> <p>This element of Lesson 2 may also include tactical changes if appropriate (unplanned hold, change of RNAV procedure, vectors)</p>
<i>Repositioning as required</i>	
3. RNAV contingencies: GPS Non-Precision Approach #5	<ul style="list-style-type: none"> As a minimum, this should include one GPS NPA in which a simulated loss of RNAV capability takes place (eg. failure of the GPS or a RAIM Loss of Integrity) during the procedure, such that the pilot must initiate the missed approach prior to the MAP. The instructor should judge the training value of then flying to an alternate airport with a conventional procedure versus simulating a restoration of GPS capability and completing the NPA on a second attempt If a simulator is used which permits other RNAV failures, these may be included (eg. a discrepancy in a cross-check between GPS position and radio aids)

GPS NPA differences training or completion of training

If the aircraft or simulator used for Lessons 1 and 2 is not representative of the actual aircraft or specific model of GPS to be used, the course should be completed using an appropriate combination of representative PC GPS simulator software, flight training device or aircraft

Element of Lesson	Content recommendations
1. Pre-flight preparation	<ul style="list-style-type: none"> <i>Briefing of route and procedure charts. Availability of non-PRNAV procedures</i> <i>RAIM check using the GPS unit's built-in prediction tool</i> <i>Review of RNAV normal and contingency checklist procedures</i>
2. Normal RNAV procedure	<ul style="list-style-type: none"> <i>To include at least one approach procedure (RNAV, or conventional using the GPS for supplementary guidance) and including at least one tactical change (unplanned hold, change of procedure, vectors)</i>

Combined P-RNAV and GPS NPA training

Training course objectives and structure

- The training for P-RNAV and GPS NPAs may be conducted as an integrated course. Much of the Ground Theory and Pre-flight Briefing content is common to both

PART 1: GROUND THEORY

Self-study method:

A pilot may use this manual to self-study the required RNAV theory content in pages with a **P** and/or **A** in the top right corner. The Instructor should, as a minimum, conduct an oral exam to ensure the pilot is fully proficient in the key knowledge items listed in the prior pages

or, Classroom training method:

The instructor may conduct classroom training to cover the key GPS NPA material in this manual. This may require several 2-3hr classroom sessions, depending on how much preparation and reading the student has done

PART 2: PRE-FLIGHT BRIEFING: The pre-flight briefing sessions may require ~2hrs, to include:

Use of RNAV Equipment: covering the four avionics topics detailed in Section 5 of this manual

RNAV Operational procedures: covering sections 3c and 4c of this manual, and using the actual aircraft or training device checklist/ops manual

- The simulator or flight training may be combined, although some P-RNAV and GPS NPA tasks need to be conducted independently (ie. not every P-RNAV arrival should be combined with a GPS NPA)

PART 3: SIMULATOR OR FLIGHT TRAINING – minimum requirements for an integrated P-RNAV and GPS NPA syllabus; see detailed lesson content for each in prior pages

1. Normal operations

To include at least one manually flown 'normal' P-RNAV SID, P-RNAV STAR and GPS NPA, and one RNAV procedure flown using the autopilot

To include one P-RNAV STAR terminating in an ILS (and, in a piston aircraft, flown at maximum approach speed)

To include one GPS NPA commencing at the procedure IAF, not from a P-RNAV arrival

To include at least one each of the following tactical changes: an unplanned hold, a change of RNAV procedure, and a direct-to clearance

2. Contingencies

To include at least 2 P-RNAV procedures, one with an RNAV failure and one with a non-RNAV failure

To include at least 2 GPS NPA procedures, one with an RNAV failure and one with a non-RNAV failure

1. Flight training

Although the syllabus refers to “Simulator or Flight Training”, training in an aircraft will often not be possible, because RNAV procedures are not available in the training area

No Instructor should ever create an RNAV procedure manually for training purposes as an alternative to using published and database-coded procedures. GPS procedure operating logic can not be simulated with manual waypoints, and this also sets the student a potentially dangerous example

2. Simulator training

Training will usually need to use a synthetic flight training device such as a JAA FNPT2 or an FAA-approved FTD (this manual refers to these as ‘simulators’, which is not strictly accurate). Many modern simulators incorporate a Garmin GNS430, which is ideal for most students. The Garmin G1000 system uses the same navigation, flight planning and procedure logic as the GNS430/530, so little or no RNAV-specific differences training is needed across these 2 platforms.

Many older simulators include Bendix/King, Trimble, Apollo and other IFR GPS units which are effectively obsolete. These are satisfactory for general IFR training, but not RNAV courses for pilots who will be flying aircraft equipped with a modern GPS

The simulator database should include a geographic coverage which allows a suitable choice of different types of procedure. For P-RNAV, simulator training may need to involve airports like Heathrow and Gatwick, rather than the regional ones more commonly used for instrument training

Paper charts should be available for all these procedures. In Europe, many AIP charts are ICAO-conforming schematics, rather than navigation charts; products from commercial suppliers, designed for in-flight use, are preferable

3. Initial Instrument Rating training

There is no reason that P-RNAV and GPS training should not be integrated with a course for an initial Instrument Rating, if the student’s budget and aptitude permit

4. Course completion certificates

Candidates may need a certificate to document they have successfully completed an RNAV course. For P-RNAV, this should note that the training is in accordance with JAA TGL10 Section 10. For GPS NPA training, a logbook endorsement that theory and practical training has been completed may be used to meet the RNAV approach requirement in some countries

5. Recurrent training

Subsequent IFR recurrent training should include, where practical, RNAV procedures and contingencies

Comments on using this manual for training courses



- Although this manual is currently available for free in electronic PDF form, the author retains copyright to its original content
- It may be used and printed for training purposes by instructors and flight schools without restriction, but must not be sold or distributed commercially
- The contents of the manual may not be copied for use in other documents and manuals without the author's permission
- The author may be contacted by PPL/IR Europe members via the website forum (www.pplir.org) with feedback and questions. Any person interested in operating light aircraft under IFR in Europe is welcome to join.

(end of document)